

thyro  switch  
3P



## Thyristor switch for reactive current compensation



## Table of Contents

1	Intended use .....	3
3	Areas of Application .....	5
4	Installation .....	6
5	Anschluss.....	7
5.1	Alternating current compensation against zero-leaders .....	7
5.2	Alternating current compensation phase against phase (only in the 400/230V Net) .....	8
5.3	Three-phase current compensation 690V Y .....	9
6	Commissioning .....	10
7	Power limitation depending on ambient temperature .....	11
8	Type Overview .....	11

The company KBR GmbH assumes no liability for damages or losses of any kind resulting from printing errors or changes in this manual.

Similarly, KBR GmbH assumes no liability for damages and losses of any kind resulting from faulty devices or devices modified by the user.

Copyright 2024 by KBR GmbH  
All rights reserved.

## 1 Intended use

The **thyro- switch 3P** is a power electronics component for connecting capacitive loads to the power network. The device is intended exclusively for installation in switchgear and controlgear. Only reactor-protect compensation stages (up to 14%) can be switched. That means: You must not switch non-reactor-protected compensation stages. First and foremost, symmetrical three-phase current compensation is intended as the application, but it is also possible to switch three separate alternating current compensation stages simultaneously.

Technical Data		
Input:	Control input	10-27V DC; 3 3 Inputs à max. 30mA
	Fuse protection	max. 6A
Supply circuit:	Auxiliary voltage	230V AC $\pm$ 10% 50/60Hz max. 35VA
	Fuse protection	max. 6A
Load circuit:	Supply voltage $U_N$	$\Delta$ 400V / 50Hz; Y 690V / 50Hz
	Load current	max. 100 A
	Power dissipation	70 A-Type approximately 3 x 1,1 W per A 100A-Type approximately 3 x 1,05W per A
Application area:	Creepage distance from control input to main circuit:	>10,5mm for SELV-voltage circuits
	Rated voltage	$U_N \pm 10\%$
	Harmonic voltage	DIN EN 61000-2-4 Class 3; THD max. 10%
Switch-on delay::		Input: 0 ... max. 20ms
Re-make tome: Cyclic operation		Input: 0 ... max. 33ms

Electrical safety:		
Standards and amendments:	Class of protection	I
	Distance	EN61010:2001 for pollution degree II; CAT III
	Degree of protection	IP10
Environmental conditions:	Standards and amendments	DIN EN 60721-3-3/A2 (3K5+3Z11) IEC 721-3-3 (3K5+3Z11)
	Operating temperature	-5°C... +55°C
	Humidity; non-condensing	5%...95%
	Storage temperature	-25°C... +70°C

Continued on next page.

Continued

Mounting:	Vertical or horizontal
Mountin position	min. 50mm to the ventilator and
Kühlabstände	min.150mm to gate cooler
Housing	220 x 182 x 188 mm (H x W x D)
Weiht	ca. 5800 g

## 2 Safety Notes

Due to the design with forced cooling, that is with the use of a fan, unimpeded air intake must in particular be guaranteed. The cooling openings must not be covered up. The distances specified from neighboring components must be observed. For nominal load, there is an increase in temperature between fresh air and exhaust air of max. 30 °C for type 70 A and of 35 °C for type 100 A. Temperature sensitive components such as cable ducts should be protected by cowls.

Temperature sensitive components such as cable ducts have to be protected accordingly.

The **thyro-~~3~~switch 3P** may only be operated with a series-connected power disconnecting device.

The **thyro-~~3~~switch 3P** cannot function alone as a component and must be project-planned for use with a compensation unit.

For detuned units, it is absolutely essential that the thyro switch 3P is connected upstream to the inductor and capacitor.

The **thyro-~~3~~switch 3P** may only be deployed in the context of its intended use. Even when used only as intended, a defect cannot be ruled out. In this case the currents and voltages in the load circuit could be affected. In case of an error, the following cases are possible: Current interruption, halfwave operation or constant energy flow. Correct design of protective devices must therefore be ensured during project planning.

Incorrect operation or wrong connections could lead to destruction of the device or the load.

The **thyro-~~3~~switch 3P** may only be connected with insulated crimping cable lugs.

Work such as assembly, maintenance and servicing may only be performed by skilled electricians. As soon as the **thyro-~~3~~switch 3P** is connected to the power supply system, the capacitive load is charged to network peak voltage. This means that the load is under voltage, even when switched off, and remains connected to the power supply. When working on the load, disconnection from the network must be made under all circumstances. Danger to life!



Even after disconnection from the network, a residual charge remains in the capacitive load. Before working on the equipment, it must be checked that the capacitors are isolated from the supply. The discharge time of the capacitors must be taken into account.

**Note:** Power capacitors must be equipped with permanently connected discharge devices and be discharged within five minutes to a residual charge of 50  $\mu\text{C}$  at most, or a to a voltage of 60 V. If this has a disturbing effect on the function of the electrical equipment, a warning sign must be put up in a clearly visible position stating that the discharge time is longer than five minutes. If it is possible to come into contact with the voltage of the capacitors, with the correct use of connectors, and these connectors can be pulled off without the use of tools, the discharge must be complete within one minute (See EN 50178, Section 5.2.5).

For the design of the discharge equipment it must be remembered that capacitors when switched off are charged to a direct voltage at the level of the network peak voltage.

The parallel operation of facilities with conventional protective relaying and semiconductor technology is only possible for reactor-protected equipment. Otherwise the **thyro- switch 3P** could be destroyed by the effects of charge transfer.

### 3 Areas of Application

The **thyro- switch 3P** is intended in particular for facilities with frequent and rapidly changing reactive power loads. The advantages of the **thyro- switch 3P** compared to conventional technology are:

- High switching speed
- Switching behavior with low system pollution
- Switching with no wearing parts
- Long working life through practically unlimited frequency of operations

#### **Areas of application:**

- Crane equipment
- Lifts
- Welding equipment
- Molding
- Wind turbines

The power switch can be operated in conjunction with VAR controllers, memory-programmable controls, computer systems and process control units.

## 4 Installation

The **thyro switch 3P** can be installed horizontally or vertically. The integrated fan controls the air flow so that nearly all the warm air produced is emitted in one direction. At maximum load, a temperature increase of max. 30°C for type 70A and of 35°C for type 100A can be expected. If temperature sensitive components are used, such as cable ducts, it is possible that cowls must be provided.

Temperature sensitive components installed in the vicinity have to be protected accordingly. The safe distances specified must be observed.

- Fan side: >50 mm
- Heat sink outlet: >150 mm

With vertical installation it must be ensured that warm air is always emitted upwards. When installing several **thyro switch 3P** on top of one another, cowls should be used.

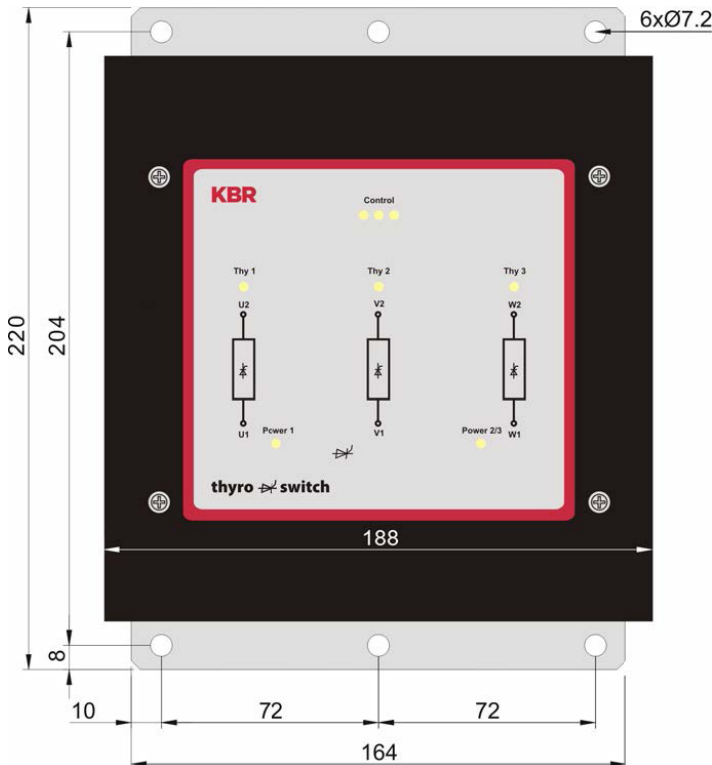

## 5 Anschluss

With a phase compensation the **thyro switch 3P** must be selected after the line-to-line voltage, i.e.:

- 1 phase compensation in the 690V/400V - net needs **thyro switch 3ph-690/400-50-100**
- 1 phase compensation in the 400V/230V - net needs **thyro switch 3ph400/230-50-100**

### 5.1 Alternating current compensation against zero-leaders

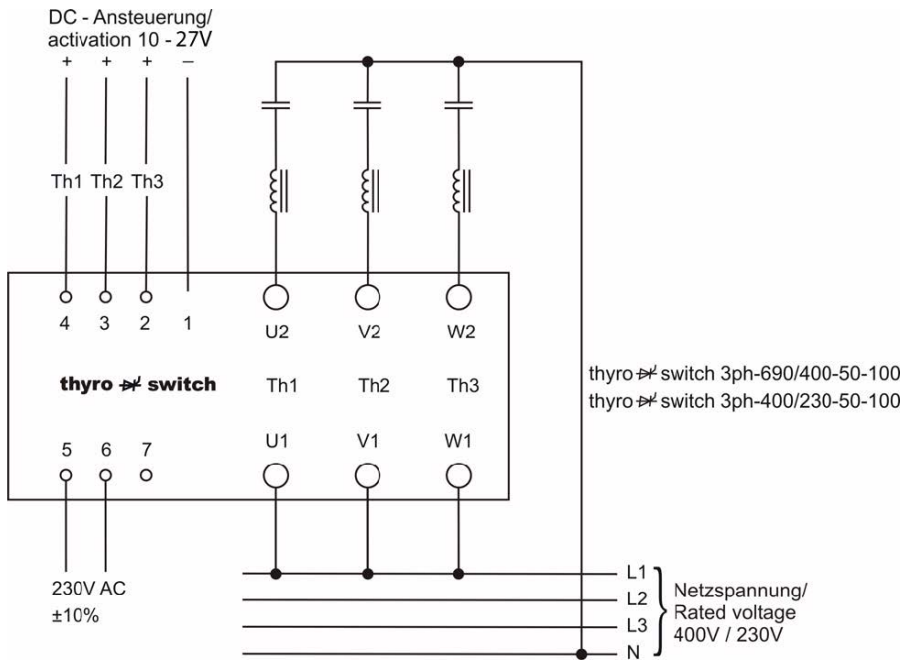

Switching example for 3 alternating current stages between L1 and N.

## 5.2 Alternating current compensation phase against phase (only in the 400/230V Net)

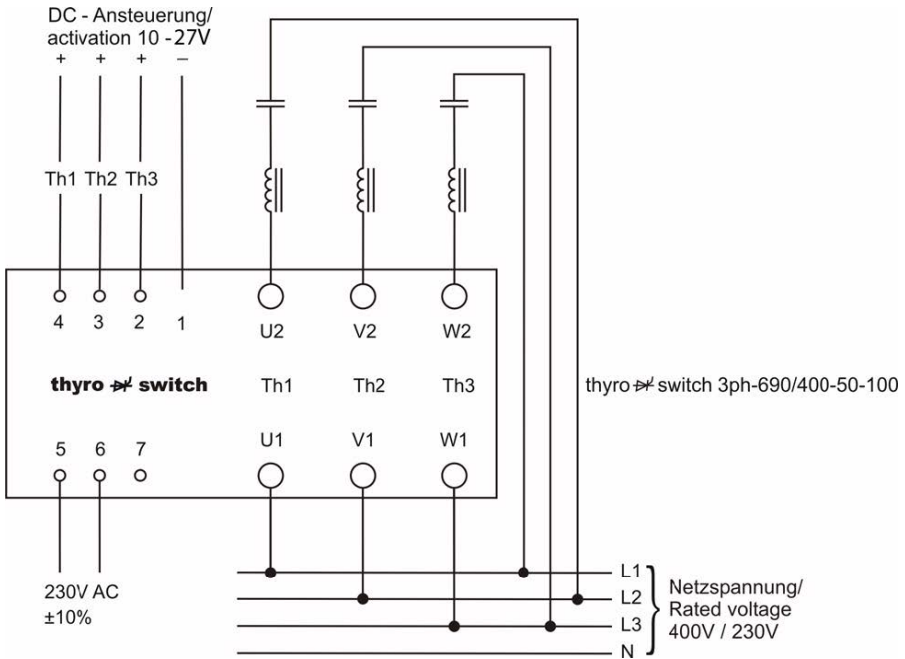

Switching example for 3 alternating current stages between L1 and L2 / L2 and L3 / L3 and L1.

### 5.3 Three-phase current compensation 690V Y

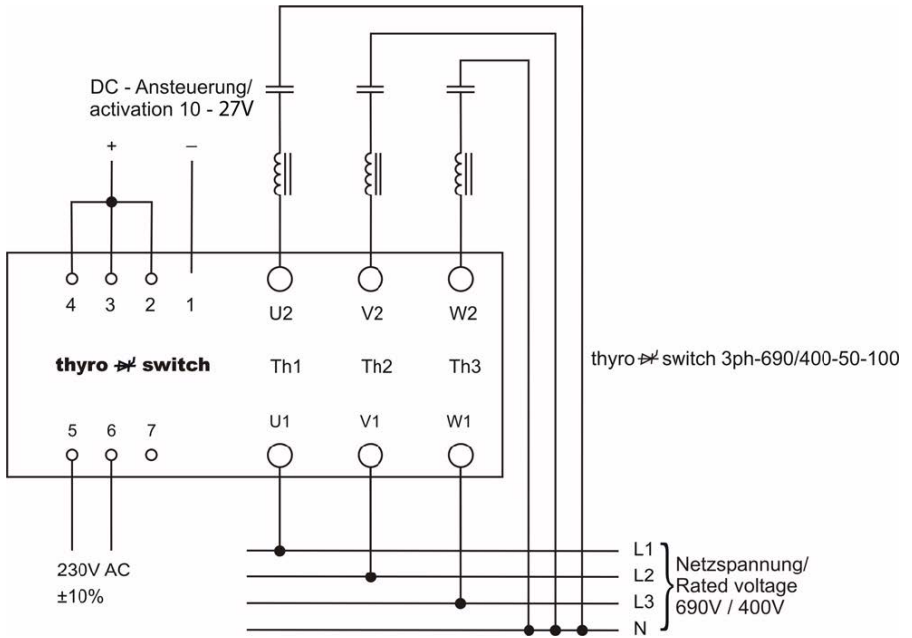

**Attention!** The neutral wire must be attached and currentload-carrying.

The gating for three-phase current compensation takes place at the same time on all 3 control inlets (1-3).

For the connection of the load current with insulated crimping cable lugs with 8mm rings, terminal studs are envisaged that must be tightened with a torque of 5.5 - 6Nm. The cable lugs must be exactly vertical to the conducting plate. When laying leads, you should ensure that the connection leads are not heated up directly by the exhaust from the heat sinks. As load fuses, fuse units for the protection of semiconductors must be used.

Project planning of their size must be made according to the connected capacitive load. You must ensure that the equipment grounding conductor is connected correctly. The equipment grounding conductor connection in the form of an M6 hexagon bolt is located on the heat sink beneath the connections for the capacitor and is labeled with the PE conductor sign .

For reactor-protected equipment it is absolutely essential that the **thyro switch 3P** is connected in series before inductor and capacitor.

**Terminal:**

4 (+)	➔ Thy 1
3 (+)	➔ Thy 2
2 (+)	➔ Thy 3
1 (-)	➔ in accordance with connection (see design on page 7, 8 und 9)

**Terminal 5 and 6:** The supply voltage 207-253 V AC with 50 or 60 Hz is connected to terminals 5 and 6. (see design on page 7, 8 and 9) .

## 6 Commissioning

1. Check the correct connections of the **thyro switch 3P**
2. Attach plastic housing
3. Switch on supply voltage („Power“ LED lights up)
4. Possible test of gating by the controller („Control“ LED lights up and fan starts up)

Control on the left	➔ LED on the left (Thy 1)	➔ Fan on the left starts up (Terminal 1-4)
Control in the center	➔ LED in the center (Thy 2)	➔ Fan in the right starts up (Terminal 2-4)
Control on the right	➔ LED on the right (Thy 3)	➔ Fan on the right starts up (Terminal 3-4)

**Note:** The operational current may only be released for the initial commissioning if no gating takes place, that is, the thyro switch 3P is switched off.

5. Connecting operational current
6. Release controller (for gating and correct function, „Power 1“ and „Power 2/3“, „Control 1-3“, „Thy 1“, „Thy 2“ and „Thy 3“ light up)

## 7 Power limitation depending on ambient temperature

Not required.

## 8 Type Overview

Type	Item-No.	Voltage	Frequency	Current
thyro switch 3ph-690/400-50-100	14344	690V/400V Y/Δ	50 Hz	100 A*
thyro switch 3ph-690/400-60-100	14345	690V/400V Y/Δ	60 Hz	100 A
thyro switch 3ph-690/500-50-70	14346	690V/500V Y/Δ	50 Hz	70 A
thyro switch 3ph-690/500-60-70	14347	690V/500V Y/Δ	60 Hz	70 A
thyro switch 3ph-860/500-50-100	25066	860V/500V Y/Δ	50 Hz	100 A*

\*Standard

Special voltages and currents on request.

**KBR GmbH**

Am Kieferschlag 7  
D-91126 Schwabach

T +49 (0) 9122 6373 -0  
F +49 (0) 9122 6373 -83  
E [info@kbr.de](mailto:info@kbr.de)

[www.kbr.de](http://www.kbr.de)