

multisio

D6-ESBDS-5DI6RO1DO-7



© KBR GmbH
We reserve the right to make
technical changes

Table of contents

1	Introduction	6
1.1	User manual	6
1.2	Intended use	6
1.3	Safety keys	7
1.4	Exclusion of liability	7
1.5	Safety instructions	7
1.6	Product liability	9
1.7	Scope of delivery	9
18	Disposal	9
1.9	Serial interface	9
1.10	Overvoltage and lightning protection	10
1.11	Explanations of terms	10
2	Installation	11
2.1	Device assembly	11
2.2	Connection diagram	12
2.3	Terminal assignment	13
2	Device memory	14
3	Range of functions	15
3.1	multisio D6-...-7 basic module	15
3.2	Available expansion modules	16
3.2.1	multisio D2-4DI-2	16
3.2.2	multisio D2-4TI-2	16
3.2.3	multisio D2-4AI-2	16
3.2.4	multisio D2-4CI-2	16
3.2.5	multisio D2-1TI2RO-2	17
3.2.6	multisio D2-4RO-2	17
3.2.7	multisio D4-4RO-ISO-1	17
3.2.8	multisio D2-4DO-2	18
3.2.9	multimes D4 power measurement module	18
3.3	Two-tariff meter function (HT/LT)	18
3.4	Configurable pulse inputs	19
3.5	Configurable pulse output (pulse totalizer)	19
3.6	Serial interface for connection to the KBR eBus	20
3.7	Extensive memory functions	20

3.8	Synchronization.....	21
3.9	Tariff switching.....	21
3.10	Software (required to configure and read out the memory)	21
<hr/>		
4	System operation.....	22
4.1	Commissioning.....	22
4.1.1	Enabling the scan mode on the device.....	22
4.1.2	LEDs.....	23
4.1.3	Reset.....	23
4.1.5	Basic configuration on delivery.....	24
4.2	Memory.....	24
4.2.1	Device settings.....	24
4.2.2	Long-term memory.....	25
4.2.3	Cycle memory.....	25
4.2.4	Event memory.....	26
4.3	Measuring period synchronization.....	26
4.3.1	Synchronization only by internal clock.....	26
4.3.2	Synchronization by the energy supplier's synchronous pulse.....	27
4.3.3	Synchronization by the KBR eBus.....	27
4.3.4	Synchronization at tariff change.....	28
<hr/>		
5	Menu overview.....	29
5.1	Main menus.....	29
5.2	Pulse counter inputs.....	30
5.3	Digital outputs.....	30
5.4	Digital inputs.....	31
5.5	Analog inputs.....	31
5.6	Power measurement inputs.....	31
5.7	Input/output status.....	32
5.8	Error messages.....	32
5.9	Settings.....	32
<hr/>		
6	Technical Data.....	42
6.1	Technical data multisio D6-...-7.....	42
6.1.1	Control and display elements.....	42
6.1.2	Device memory.....	42
6.1.3	Power supply.....	42
6.1.4	Hardware inputs.....	42

6.1.5	Electrical connection.....	43
6.1.6	Hardware outputs.....	43
6.1.7	Mechanical data.....	44
6.1.8	Dimensioned drawing.....	44
6.1.9	Surrounding conditions/electrical safety	44
6.1.10	Troubleshooting.....	45
6.2	Technical data of the display.....	45
6.2.1	Power supply	45
6.2.2	Hardware inputs and outputs.....	45
6.2.3	Electrical connection.....	45
6.2.4	Mechanical data.....	45
6.2.5	Surrounding conditions/electrical safety	46

1 Introduction

Thank you for choosing this KBR quality product.

To become familiar with the operation and programming of the device and to use the full range of functions of this high-quality product at all times, you should read this user manual carefully.

The individual chapters explain the technical details of the device and show how damage can be avoided through proper installation and commissioning.

1.1 User manual

This user manual describes the device version multisio D6-...-7. This user manual must be accessible to the user at all times (e.g. in the switchgear cabinet). Even if the device is resold to third parties, the manual remains an inherent part of the device.

Although the utmost care has been taken in writing this user manual, errors may still occur. We would be very grateful if you would notify us of any errors or unclear descriptions you may notice.

1.2 Intended use

multisio is a modular system that records and processes signals. You can select from a wide range of functions depending on the input or output types. This system is able to record the pulses from consumption meters, saving them as both continuous meter data and as standard-compliant load profiles.

Alternatively, a digital input can also be used for summarization (switching protocol) or to record the operating hours.

Up to five expansion modules each for a wide variety of signal types can be connected to a central memory unit via ready-made RJ45 cables.

1.3 Safety keys

This manual contains instructions that you must follow for your personal safety and to avoid material damage. These instructions are identified by a warning sign or information symbol, depending on the degree of hazard they warn about.



DANGEROUS VOLTAGE

means that death, serious personal injury or considerable material damage will occur if the appropriate precautions are not taken.



CAUTION

means that slight personal injury or material damage may occur if the appropriate precautions are not taken.



NOTE

This is an important piece of information about the product, the handling of the product or the relevant part of the user manual to which particular attention should be drawn.

1.4 Exclusion of liability

The contents of this document have been checked using the hardware and software described. However, deviations cannot be excluded and therefore complete conformity cannot be guaranteed. The information in this publication is checked regularly; necessary corrections will be made in subsequent editions. We appreciate your corrections and comments.

1.5 Safety instructions

In order to prevent operating errors, handling of the device has been kept as simple as possible. This will enable you to start use the device quickly. It is in your own interest to read the following safety instructions carefully.

**DANGEROUS VOLTAGE****The applicable DIN/VDE regulations must be observed during installation!**

Connection to the mains, commissioning and operation of the device may only be carried out by qualified personnel. Qualified personnel within the meaning of the safety instructions in this manual are persons with electrical engineering training and knowledge of national accident prevention regulations, safety engineering standards and the installation, commissioning and operation of the device.

To prevent fire and electric shock, do not expose the device to rain or moisture! Before connecting the device to the power supply, check whether the local power supply conditions comply with the specifications on the device name-plate.

Incorrectly connecting the device can damage it.

When connecting the device, adhere to the information given in the connection diagram (see "Connection diagram") and that the connecting cables are not live. When wiring, always ensure that all cables used are neither damaged nor faulty

and observe correct polarity!

Proper and safe operation of the product requires correct transport, storage, installation and assembly as well as careful operation and maintenance.

If the device has any visible damage it is considered unfit for use and must be disconnected from the power supply! Troubleshooting, repairs and maintenance work may only be carried out at our plant or after contacting our customer service team.

If the device is opened without authorization, any warranty or guarantee claim is forfeited. Error-free functioning is no longer guaranteed.

When the device is opened, live parts may be exposed. Capacitors in the device may still be charged even if the device has been disconnected from all voltage sources. Do not operate open devices under any circumstances!

Lightning protection measures must be provided for all input and output cables in systems at risk from lightning strikes. (See the chapter "Protective measures".)

**CAUTION**

Do not connect any external voltage source to terminals 50–59.
Only apply safe-to-touch extra-low voltage in accordance with UL/CSA/IEC 61010-1 to terminals 80 and 81.
See Technical Data for maximum values.

1.6 Product liability

You have purchased a high-quality product. Only top-quality components with exceptional reliability are used.

Each device undergoes a long-term test before delivery.

With regard to product liability, please see our general terms and conditions for electronic devices, which you can read at www.kbr.de.

The guaranteed device characteristics are generally only valid for intended use!

1.7 Scope of delivery

Included in the scope of delivery:

- multisio device
- Connector kit
- User manual

18 Disposal

Please dispose of defective, out-of-date or no longer used devices properly.

If required, we will dispose of the device for you.

1.9 Serial interface**RS 485 bus operation**

The RS485 interface of the **multisio D6-...-7** is designed for operation at the KBR eBus. With the eBus, you can operate one or several **multisio D6-...-7** devices across great distances. The bus is connected to the computer via the KBR eBus TCP gateway. All bus devices can be configured and visualized with the aid of the associated KBR® software. We will be glad to provide information on which other devices you can connect to the KBR eBus as well as on the functionality of our software.

You can find more information on the structure and technical parameters of the KBR eBus in our KBR eBus installation guide. We are happy to provide you with these installation guidelines on request.

1.10 Overvoltage and lightning protection

We recommend installing surge protection measures to prevent damage to our high-quality electronic equipment. Protect control voltage inputs, pulse and bus lines.

1.11 Explanations of terms

Below you will find a brief explanation of the terms used in this manual.

Firmware:	The operating system software implemented in the microcontroller of the multisio D6-...-7 .
Load profile memory:	Saves the actual values of the measurement periods with timestamp.
Measuring period maximum values:	The measuring period containing the highest (maximum) value that occurred.
Period value:	Cumulative value within a measuring period.
Measuring period:	Refers to the period of time used to form average values. Typical intervals are e.g. 15, 30 or 60 minutes.
DIN rail:	DIN rail/mounting rail acc. to DIN EN 50022

2 Installation

This chapter describes:

- „Device assembly“ on Page 11
- „Connection chart“ on Page 12
- „Terminal assignment“ on Page 13

2.1 Device assembly

The housing of the multisio D6-...-7 has been designed for switchgear cabinet mounting on a 35 mm DIN rail. The module is snapped on the mounted DIN rail.



CAUTION

The device control voltage must be secured with a back-up fuse on site. The electrical installation of the building must have a disconnecter or circuit breaker for the power supply voltage. The disconnecter must be close to the device and be easily accessible to the user. It must be marked as an isolating switch for this device. The isolating switch must be UL/IEC-approved.

For the wiring of the pulse output, we recommend to exclusively use shielded twisted pair material to avoid disturbances (e.g. installation line I-Y(ST) Y 2 x 2 x 0.8 mm. The shielding may only be connected on one side).

During installation, please also observe our instructions on safety measures against overvoltage and lightning in the chapter “Overvoltage and lightning protection” on Page 10.

2.2 Connection diagram

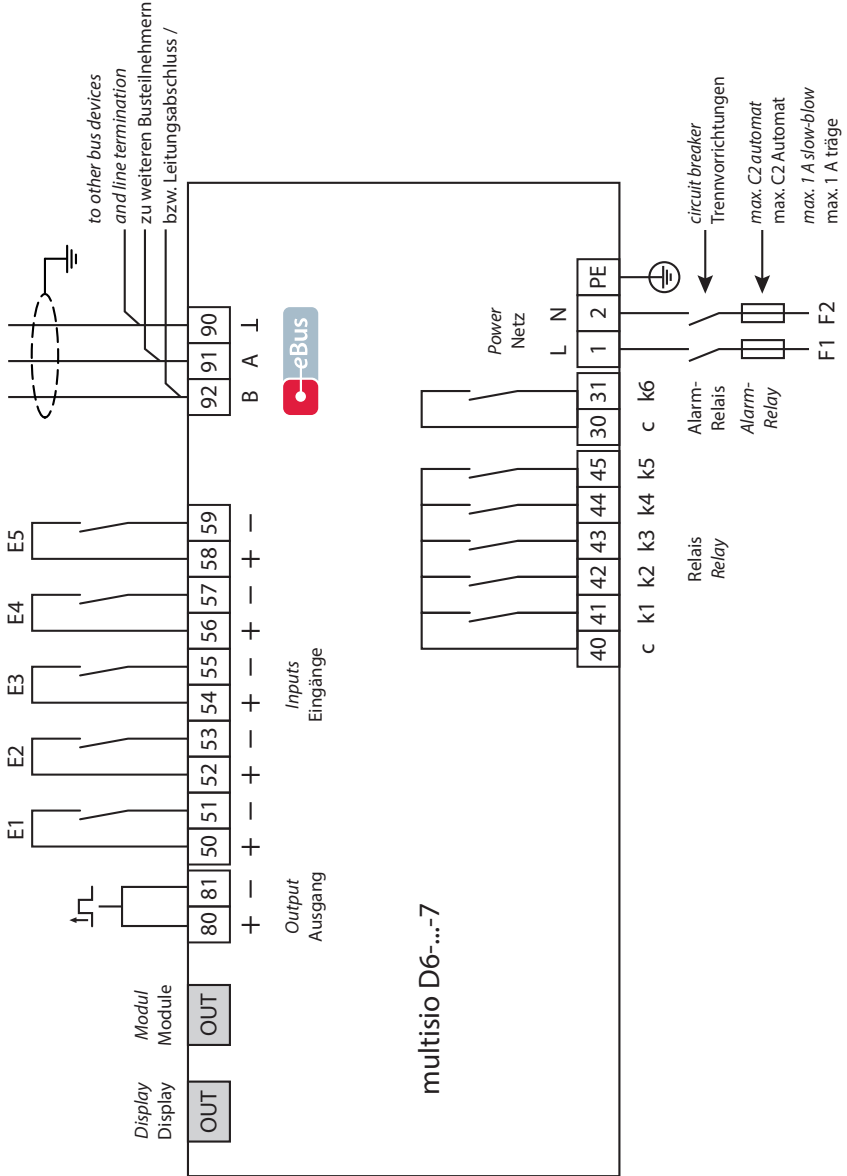

2.3 Terminal assignment

Terminal 40 and 41: (AC)/2 A	Relay contact, switching capacity 250 V
Terminal 40 and 42: (AC)/2 A	Relay contact, switching capacity 250 V
Terminal 40 and 43: (AC)/2 A	Relay contact, switching capacity 250 V
Terminal 40 and 44: (AC)/2 A	Relay contact, switching capacity 250 V
Terminal 40 and 45: (AC)/2 A	Relay contact, switching capacity 250 V
Terminal 30 and 31:	Floating relay contact, switching capacity 250 V (AC)/2 A For error message transmission, e.g. to a master central process control.
Terminal 1 (L)/2 (N) and PE:	Voltage supply US1: $\approx 100\text{--}240\text{V} \pm 10\%$ DC/50/60 Hz
Terminal 80 (+) and 81 (-):	Pulse output for pulse totalizer
Terminal 50 (+) and 51 (-):	Meter input 1
Terminal 52 (+) and 53 (-):	Counter input 2
Terminal 54 (+) and 55 (-):	Meter input 3
Terminal 56 (+) and 57 (-):	Meter input 4
Terminal 58 (+) and 59 (-):	Meter input 5 A floating contact of a pulse generator can be connected to these inputs.
Terminal 92 (B)	Bus connection
91 (A)	For communication on the KBR eBus
90 (ground):	
Out	Module bus connection For communication with expansion modules
Display	Display connection For communication with the display

2 Device memory

Non-volatile long-term memory

The device is equipped with an internal, non-volatile memory in which long-term data is stored.

Buffered real-time clock (RTC)

After an uninterrupted charging time (device connected to the supply voltage) of approx. eight hours, the buffer capacitor will have a sufficient charge to protect the internal clock from failure due to lack of operating voltage for approx. 14 days.



NOTE

If the buffer capacitor is discharged and there is no supply voltage, once the device has been switched on the time settings will be incorrect and must therefore be reset.

3 Range of functions

3.1 multisiso D6-xxx-7 basic module

multisiso D6-xxx-7 is the central memory module for the multisiso signal recording system. It can record pulses from various pulse generators via five S_0 -compatible inputs. The input pulses of each input are added and divided up into measuring periods, provided with a timestamp and stored in an internal ring buffer. For a measuring period duration of 15 minutes this results in a recording duration of 40 days. A synchronized pulse input can be set up for direct synchronization, and addressed via a floating contact. The floating error message contact of the **multisiso D6-xxx-7** can be used to monitor errors and for transmission to a central process control, for example (selectable via a KBR eBus NC or NO contact). The five other non-floating relay outputs can be assigned to KBR eBus relay groups and used as NO or NC contacts (selectable via KBR eBus).

The **multisiso D6-xxx-7** has a display interface to connect the multisiso F6-DS display with a ready-made RJ12 modular cable. This provides for convenient start-up and configuration of the **multisiso D6-xxx.....-7**. In addition, instantaneous values and messages can be displayed.

The following limits are defined for:

Energy meter	– Operating hours
Current measurement	– Momentary current – Operating hours
Digital input	– Operating hours
Temperature input	– Momentary temperature – Operating hours
Analog input mA/V	– Momentary value – Operating hours

Power measurement module multimes D4:

Parameters:	– Limit 1 instantaneous power – Limit 2 instantaneous power – Operating hours counter
-------------	---

You can program any limit, the address of the message output and values for the limit exceeded or undercut.

3.2 Available expansion modules

For greater functionality, the device is equipped with a module bus interface that supports up to five additional modules:

3.2.1 multisisio D2-4DI-2

The hardware of the **multisisio D2-4DI-2** supports four S₀-compatible digital inputs.

The **multisisio D2 4DI-2** manages the digital inputs with two different methods you can choose from. You can configure each input separately as a pulse counter input or state-controlled input.

3.2.2 multisisio D2-4TI-2

The hardware of the **multisisio D2-4TI-2** supports four PT-1000 temperature inputs.

The module evaluates the measured values of the temperature sensors connected to terminals 70 and 71 etc.

3.2.3 multisisio D2-4AI-2

The hardware of the **multisisio D2-4AI-2** supports four analog inputs.

With its four analog measuring inputs, current values from 0 to 20 mA and voltage values from 0 to 10 V can be measured. The four input LEDs indicate the status of the analog inputs (when used with the multisisio D6...-5, the module is always set up for 0–20 mA/0–10 V, meaning the LEDs of inputs 1–4 are always on).

3.2.4 multisisio D2-4CI-2

The hardware of the **multisisio 1D2-4CI-2** supports four analog current measuring inputs and one LED. It can measure currents of up to 6 A. The device LED flashes or is permanently lit to indicate different device statuses.



CAUTION

Only operate the multisisio D2-4CI-2 with series-connected current transformers! The transformers may not be secondarily grounded. Up to the 690 V network (phase-phase voltage), the current transformers connected upstream have to be designed for a test voltage of at least 2,500 V AC for one minute.

3.2.5 multisio D2-1TI2RO-2

The hardware of the multisio D2-1TI2RO-2 supports one PT-1000 temperature input and two floating relay outputs.

The module evaluates the values measured by the temperature sensor connected to terminals 51 and 52 and switches the relays in accordance with the limits transmitted by the master device.

The relay outputs are used to control the fan or as an alarm relay.

Example:

Alarm switching threshold = 28 °C/hysteresis = 5 °C

Fan relay switches on at 28 °C and off at 23 °C

Alarm switching threshold = 50 °C/hysteresis = 5 °C

Alarm relay switches on at 50 °C and off at 45 °C

3.2.6 multisio D2-4RO-2

The hardware of the multisio D2-4RO-2 supports one non-floating control voltage input and four non-floating relay outputs.

Each relay output can be used individually as alarm output, message output for limit violations or digital output.

They can also optionally be assigned to a KBR eBus relay group.

3.2.7 multisio D4-4RO-ISO-1

The hardware of the multisio D4-4RO-ISO-1 supports four floating relay outputs.

Each relay output can be used individually as alarm output for limit violations or digital output.

They can also optionally be assigned to a KBR eBus relay group.

3.2.8 multisisio D2-4DO-2

The hardware of the multisisio D2-4DO-2 supports four digital outputs.

At its outputs, the module provides digital pulses, in accordance with the configuration made by the multisisio D6-...-7 master device via module bus.

For each hardware output, a voltage of up to 35 V has to be applied to the + input. When the digital output is "On," it transfers this voltage to the corresponding terminal. To ensure that the current applied does not exceed 50 mA, external wiring is necessary. With these parameters, the digital output is S_0 -compatible in accordance with DIN 43864.

Ensure that the polarity is correct when connecting.

3.2.9 multimess D4 power measurement module

The hardware of the multimess D4 supports three current measuring inputs, four measuring voltage inputs (L1 - L2 - L3 - N) and one status LED. Current measurements are possible up to a maximum of 6 A AC and voltage measurements up to 230 V AC Ph-N. The LED displays different device states by flashing or continuous illumination.

The measuring device is powered by the measuring voltage (50 V AC minimum). The bus interface is powered via the module bus interface.

Configurable limits are available for:

- Instantaneous power limit 1
- Instantaneous power limit 2
- Operating hours counter

For each measuring module, the parameter to be monitored can be selected. If a parameter exceeds or falls below the set limit, the specified limit relay will issue a corresponding message.

3.3 Two-tariff meter function (HT/LT)

Consumption is recorded separately for the different tariff periods. Tariff switching can either be controlled with a digital input, the KBR eBus (centrally from the multimaster or computer) or by internal clock.

3.4 Configurable pulse inputs

The five configurable pulse inputs, implemented as an S_0 interface, can process pulses from pulse generators up to an input frequency of 16 Hertz (minimum pulse length 30 ms, pulse/idle time ratio 1:1). All five pulse inputs are configurable independently of each other. This applies to the configuration of their pulse value (number of pulses per unit) as well as unit (e.g. pulses/kWh). These functions are available via the KBR eBus.

Each pulse is visualized by a flashing LED.

The pulse inputs can be optionally used as:

- Pulse counter
- Heat meter (when using expansion modules with temperature inputs such as the multisio D2 4TI-2 or multisio D2 1TI2RO-2)
- Digital input (status display)
- Synchronous pulse input
- Tariff switching
- Operating hours counter

3.5 Configurable pulse output (pulse totalizer)

The configurable pulse output can optionally be used as:

- Alarm output
- Digital output
- Limit alarm
- Pulse generator
- Pulse totalizer, with the output, implemented as an S_0 interface, able to process pulses up to an output frequency of 16 hertz (minimum pulse length 30 ms, pulse/idle time ratio 1:1).
- Up to nine pulse inputs can be totaled or subtracted (five at the basic module + four at an expansion module). If the module bus is extended via multisys gateway, even remote counters can be totaled. If only one pulse input is selected as source, this at the same time enables pulse extension via Energy Bus. In this case, observe the following: Input pulses are recorded up to a maximum frequency of 20 Hz. However, output pulses are emitted with a maximum of 16 Hz. Due to the pulse value adaptation, this is however no real limitation in practice.

3.6 Serial interface for connection to the KBR eBus

In its default configuration, the **multisio D6-xxx-7** has a serial interface (RS485) for operation with the KBR eBus.

Configuration of the unit, as well as reading out the momentary (= instantaneous) or memory data, is possible only via the KBR eBus.

3.7 Extensive memory functions

The **multisio D6-xxx-7** provides extensive memory functions:

- Period memory for recording the cumulative input pulses (separate for each input). 5 x 3,840 cycle entries; depending on the connected expansion modules, up to 25 x 3,840 cycle entries are possible.
- Event memory (1,500 entries) to log different actions of the **multisio D6-xxx-7** such as power failure, tariff switching, delete functions and many more.
- Operation logbook (500 entries) for logging events caused by the device operation (with timestamp).

This includes:

- Each address allocation (date and new address)
- Each parameter change (date and "parameter change"
- Enabling and disabling the project parameter protection date and "PPP activated"/"PPP deactivated")
- Each supply voltage loss and return. (date and event)

User- and device-specific events (limit violations, switching actions and faults etc.) are not stored in the operating logbook, but in the event memory.

These memory functions are only available via the KBR eBus.

3.8 Synchronization

For synchronization of the load profile memory, each digital input can be optionally configured in the **multiso D6-xxx-7**. Here the synchronization signal of the energy supplier can be connected, for instance. Synchronization can also be controlled centrally via the KBR eBus.

3.9 Tariff switching

For tariff switching, each digital input can be optionally configured in the **multiso D6-xxx-7**. You can, for example, connect the tariff switching signal of the energy supplier. Tariff switching can also be controlled centrally via the KBR eBus or via internal clock (refer to chapter Two-tariff counter function).

3.10 Software (required to configure and read out the memory)

The **visual energy** product line is used to easily program and store long-term data.

If you have any questions about this device or in general about our software products, simply get in touch. We will be happy to help you. You will find the contact address on the cover page of this user manual.

4 System operation

4.1 Commissioning

4.1.1 Enabling the scan mode on the device

Using a suitable screwdriver, lift off the housing cover at the four notches provided for this purpose.

Press the button in the middle of the display for approx. three seconds.

The LEDs flash.

During this phase, addresses can be assigned via the KBR eBus PC software. Details of this can be found in the user manual for the corresponding computer software.

After the address has been assigned successfully, the device enters normal operation. You can also start the scan mode via the display (window: Settings, menu item: Bus parameters):

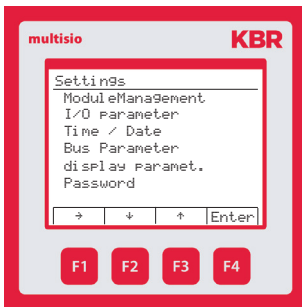

Use the Bus parameters item (KBR eBus) to configure bus operation. You can set the bus address for the BKR energy bus here as well.

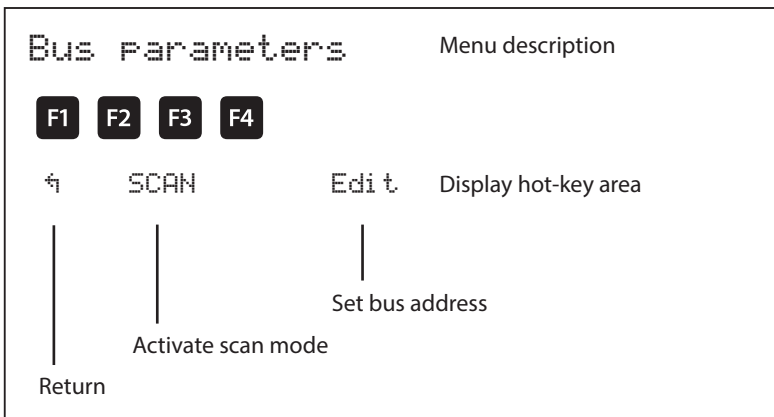

Parameters: Bus address 0 to 9999

4.1.2 LEDs

- “Power” LED This LED lights up when the device power supply is connected. The device can be operated with a voltage from 100 V to 240 V. See the chapter Technical Data.
- LED “1–5” This LED **flashes** whenever the corresponding **pulse input** is active.

4.1.3 Reset



NOTE

Reset procedure:

Disconnect the device from the power supply. Using a suitable screwdriver, lift off the housing cover at the four notches provided for this purpose.

Press the button in the middle of the display board and hold it down.

Switch the voltage supply back on.

The LEDs stay on.

As soon as you release the button, the device returns to its default state; data and parameter memory are deleted.

You can also perform a reset via the display (window: Settings, menu item: Password).

4.1.4 Default settings after reset

Pulse value counter channels 1 to 5	1 pulse/unit
Energy form counter channels 1 to 5	Current
Measurement period duration counter channels 1 to 5	15 min.
Assignment of counter channels 1 to 5	Main module, lines 1 to 5
Synchronization type counter channels 1 to 5	via KBR eBus
Operating hours counter channels 1 to 5	no allocation, normally open
Inputs channels 1 to 5	no allocation, normally open

Relay outputs 1 to 5	Main module, line 1 to 5, turnkey logic, no relay group allocation
Daylight saving time	from months 03 to 10
Energy form of external Synchronous input	Current
Logic of external synchronous input	Normally open
Tariff switching	via KBR eBus
Tariff	HT
Default setting with tariff switching triggered by time of internal clock.	Start time: LT starts at 00:00 AM End time: LT ends at 00:00 AM
All measurements	Restart
Memory	Deletion of entire memory
Measuring period memory:	Deletion of all entries
Alarm relay	Error message dialog completely set, NC contact logic
Password	Basic setting 9999 device can be accessed

Unaffected by a RESET:

Bus address and time

4.1.5 Basic configuration on delivery

Bus address	0000
-------------	------

4.2 Memory

4.2.1 Device settings

All device settings and configuration data for the memory function are stored in the device.

4.2.2 Long-term memory

The **multisiso D6-xxx-7** provides the user with the long-term memory described below:

4.2.3 Cycle memory

The **multisiso D6-xxx-7** has a cycle memory which can record up to 5 x 3,840 entries depending on the measuring period selectable by the user (possible period values 60/30/15/1 minute(s)).

This means that a period of 60 minutes results in a maximum storage duration of 160 days.

The measurement period can be configured using the computer with the optionally available software.

When all five additional modules are connected, the cycle memory is increased to a total of 25 x 3,840.



NOTE

Setting the device-internal clock:

If the time of the **multisiso D6-xxx-7** is adjusted by less than the duration of one period, the measurement for the instantaneous period is finished at the next synchronization event and saved.

If the time of the **multisiso D6-xxx-7** is moved back by more than the duration of one period, the load profile memory is deleted and restarted. In both cases, a clock adjustment event is created and saved in the event memory.



NOTE

Adjusting the period duration:

If the period time is adjusted, the load profile memory is deleted and restarted. An adjustment event (adjustment of the period duration) is created and entered in the event memory.

4.2.4 Event memory

The event memory saves 1,500 events with date, time and status in a ring buffer.

The following events are recorded:

Event	Recording
Tariff switching (via KBR eBus)	Switchover signal => HT with date and time Switchover signal => LT with date and time
Sync input	Missing synchronous pulse with date and time
Power failures	with date, time and duration of the power failure
Error	Error type with date and time
Setting changes / deletions	e.g. reset via KBR eBus/set clock/deletions / general Parameter changes



NOTE

The described memories can only be read out or configured via the KBR eBus by means of optionally available software (e.g. visual energy).

4.3 Measuring period synchronization

Measuring period synchronization of the **multisio D-xxx-7** can be performed in four different ways. The measurement period synchronization depends on the energy type of the sync input of the **multisio D-xxx-7** and of the individual inputs. This means that, for example, only inputs with the same energy form as the device's sync input are synchronized.

The following four types of synchronization are possible:

4.3.1 Synchronization only by internal clock

Synchronization by internal clock is started with the factory reset. From this start time on, the clock synchronizes the measuring period every 15 minutes, depending on the measuring period duration set. Provided the period duration corresponds to the 60-minute schedule, the synchronization time is always 00:00 am (hh:mm).

4.3.2 Synchronization by the energy supplier's synchronous pulse

If the synchronous pulse is available as a floating contact from the energy supplier, it may be connected to an input configured as a synchronous pulse input. If the contact closes for at least 250 ms, it is detected as a synchronous pulse and the measurement period of the input with the same energy form as the synchronization input is restarted.

Under certain operating conditions, the power supply company may post-synchronize during an ongoing measurement period.

The **multisio D6-xxx-7** terminates the running period measurement and saves the period value with a timestamp.

Example:

Period time is set to 15 minutes,

i.e. 20 kW input power results in a period value of 20 kW (15-minute period).

If an intermediate synchronization is performed three minutes after period start and this three-minute period is saved, the period value to be recorded is 4 kW.

If no synchronous pulse from the energy supplier is detected, the error message **External synchronous pulse missing** will be displayed and the internal clock will continue the time pattern.

4.3.3 Synchronization by the KBR eBus

Synchronization is carried out via a telex created either by the computer or MULTIMASTER and sent to the selected recipients via the KBR eBus. This telegram contains the energy form of the input to be synchronized.

Under certain operating conditions, post-synchronization may occur during an ongoing measurement period.

multisio D6-xxx-7 terminates the running period measurement and saves the period value with a timestamp.

Example:

Period time is set to 15 minutes, i.e. 20 kW input power results in a period value of 20 kW (15-minute period).

If an intermediate synchronization is performed three minutes after period start and this three-minute period is saved, the period value to be recorded is 4 kW.

If no BUS synchronous pulse is detected, the error message **External synchronous pulse missing** will be displayed and the internal clock will continue the time pattern.

4.3.4 Synchronization at tariff change

The internal clock synchronizes the measurement period. Depending on the configuration of the inputs, the measurement period is synchronized if the tariff is changed.

Under certain operating conditions, the synchronization pulse and internal measurement period synchronization may not correspond to the same time pattern. The **multisio D6-xxx-7** terminates the running period measurement and saves the period value with a timestamp.

Example:

Period time is set to 15 minutes,

i.e. 20 kW input power results in a period value of 20 kW (15-minute period).

If a synchronization is performed three minutes after period start and this three-minute period is saved, the period value to be recorded is 4 kW.

5 Menu overview

5.1 Main menus

Main menus

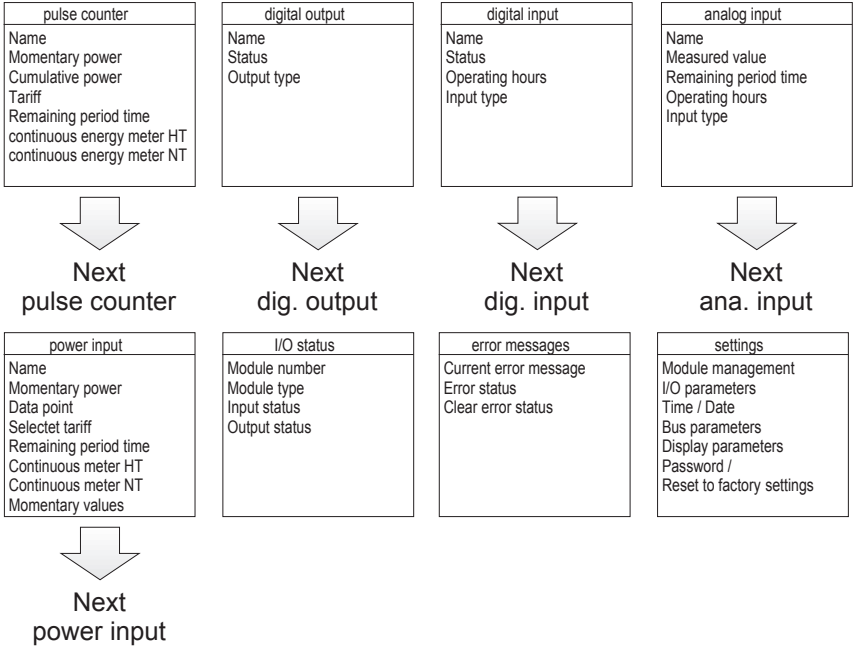

menu settings

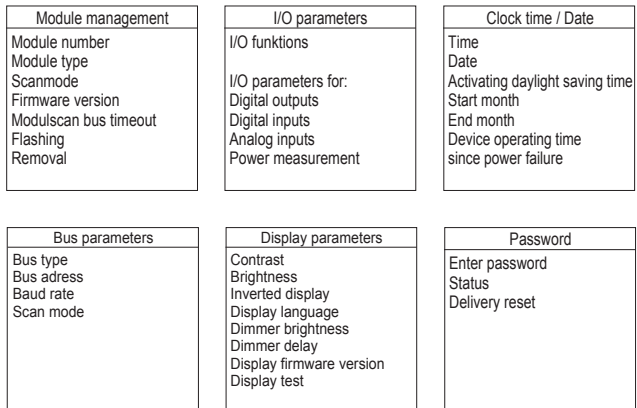

Operation of the device is not only possible with the visual energy software; you can also use the multisiso F96-LCD-7 display for your entries.

Below is an overview of the display windows and a list of the menu points in the windows.

5.2 Pulse counter inputs

Window 1

Counter name
 Instantaneous power
 Cumulative power
 Tariff
 Remaining period time
 Continuous energy meter, high tariff
 Continuous energy meter, low tariff

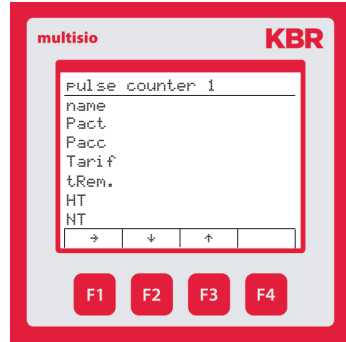

5.3 Digital outputs

Window 2

Counter name
 Status
 Output type

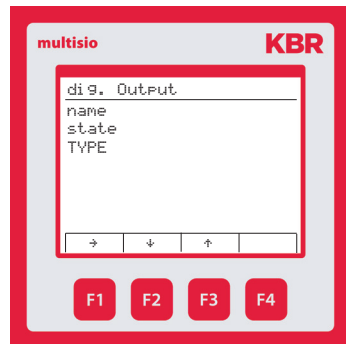

5.4 Digital inputs**Window 3**

Input name

Status

Operating hours

Input type

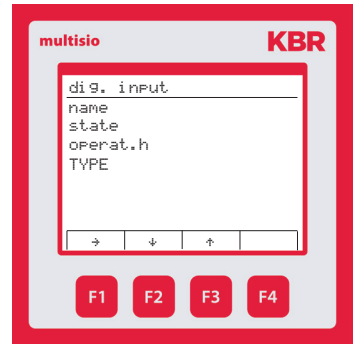
**5.5 Analog inputs****Window 4**

Input name

Measured value

Remaining period time

Operating hours

Input type

**5.6 Power measurement inputs Window 5**

Input name

Instantaneous power

Data point

Selected tariff

Remaining period time

Continuous meter HT

Continuous meter LT

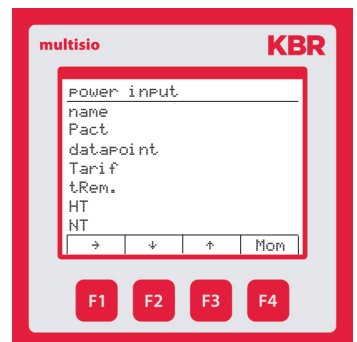

5.7 Input/output status
Window 6

Module number/type/state/value

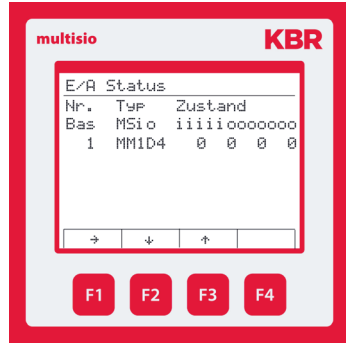

5.8 Error messages
Window 7

Current error message
 Reset message status



5.9 Settings
Window 8
 Submenus

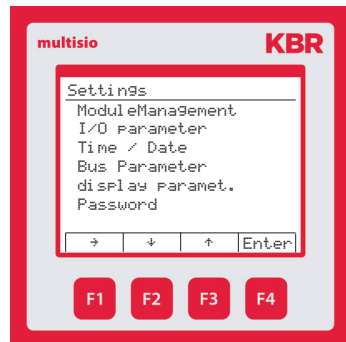

Status messages (must be acknowledged)

E01	Power failure has occurred
E02	A limit has been violated
E03	Counter pulse missing
E04	External synchronized pulse missing
E05	Reset has been performed
I06	Time invalid
E07	Error message

Active error messages (automatically reset)

E10	Limit violated (module/channel specification)
E11	Firmware download active
E12	Limit consumption monitoring violated
E13	RTC capacitor empty
E14	Parameter error (default value replaces error value)
E15	Module bus error
E18	Error module 1 (cannot be reached)
E19	Error module 2 (cannot be reached)
E20	Error module 3 (cannot be reached)
E21	Error module 4 (cannot be reached)
E22	Error module 5 (cannot be reached)

Main menu	Submenus	Input/output	Functions	Menu points	Parameters
Settings					
	Module administration				
	I/O parameters		Module type		
	Clock time/date		Firmware version		
	Bus parameters		Module bus timeout		
	Display parameters		Flashing		
	Password		Removal		
	I/O parameters				
	Clock time/date	Digital input	Pulse counter		
	Bus parameters			Counter parameters	
	Display parameters				Counter name
	Password				Inversion
					Pulse value
					Primary voltage transformer
					Secondary voltage transformer
					Primary transformer current
					Secondary transformer current
					t Pmom => 0
					Activate counter failure message

24402_EDEBD A0267-3724-1_EN

Main menu	Submenus	Input/output	Functions	Menu points	Parameters
Settings					
	I/O parameters				
	Clock time/date	Digital input	Pulse counter		
	Bus parameters			Period memory parameters	
	Display parameters				Tariff switching type
	Password				Start LT time at "internal"
					Stop LT time at "internal"
					Energy type
					Period duration
					Synchronization type

Main menu	Submenu	Input/output	Functions	Menu points	Parameters
	I/O parameters				
	Clock time/date	Digital input		Operating hours parameters	
	Bus parameters				Trigger count
	Display parameters				over/below threshold value Pnom
	Password				Threshold value Pnom
					Limit value in hours
					Message output

Main menu	Submenu	Input/output	Functions	Menu points	Parameters
	I/O parameters	Digital input			
	Clock time/date		Digital input		
	Bus parameters				Input name
	Display parameters				Activate operating hours counting
	Password				Count for active/passive
					Activate limit alarm
					Limit value in hours
					Message output
			Synchronous input		
					Input name
					Inversion
					Energy type
			Tariff switching		
					Input name
					Inversion
					Tariff if activated
					Energy type

Main menu	Submenu	Input/output	Functions	Menu points	Parameters
	I/O parameters	Digital input	Heat meter		
	Clock time/date				Input name
	Bus parameters				Inversion
	Display parameters				Pulse value
	Password				Specific heat quantity
					Supply flow temperature input
					Return flow temperature input
					t Pmom => 0
					Activate counter failure message
			Operating hours counter		
					Input name
					Inversion
					Activate limit alarm
					Limit value threshold (hours) for message output
					Message output
			Period memory parameters		
					Tariff switching type
					Start LT time at "internal"
					Stop LT time at "internal"
					Energy type
					Synchronization type
			Disabled		

Main menu	Submenu	Input/output	Functions	Menu points	Parameters
	I/O parameters	Relay output	Alarm relay		
	Clock time/date				Output name
	Bus parameters				Inversion
	Display parameters				active in case of message
	Password	Digital output relay			
					Output name
					Inversion
					Relay group
		Relay output	Limit alarm		
					Output name
					Inversion
					ON delay
					OFF delay
		Temperature alarm with multisio T112RO			
					Output name
					Inversion
					active if value falls below
					Threshold value
					Hysteresis
		Disabled			

24402_EDEBD00267-3724-1_EN

Main menu	Submenu	Input/output	Functions	Menu points	Parameters
	I/O parameters	Digital output	Digital output pulse		
					Output name
					Inversion
					Relay group
			Pulse totalizer		
					Output name
					Pulse length
					Pulse value
					Selection of meter inputs 1 to 9
			Pulse generator		
					Output name
					Pulse length
					Pulse pause
					Pulse delay
			Disabled		

Main menu	Submenu	Input/output	Functions	Menu points	Parameters
Settings					
	Clock time/date				
	Bus parameters				Time
	Display parameters				Date
	Password				Activate daylight saving time
					Start month
					End month
					Device operating time since power failure
	Bus parameters				
	Display parameters				Bus type
	Password				Bus address
					Baud rate
					Scan mode
	Display parameters				
	Password				Contrast
					Brightness
					Inverse display
					Display language
					Dimmer brightness
					Dimmer delay
					Display firmware version
					Display test
				Options	
					Bar
					Buzzer
					long timeout
					Zero-point creator

24402_EDEBD0A0267-3724-1_EN

Main menu	Submenu	Input/output	Functions	Menu points	Parameters
Settings					
					Password input
					Status
					Delivery reset

6 Technical Data

6.1 Technical data multio D6-xxx-7

6.1.1 Control and display elements

Operation	Pushbutton for reset and scan mode (accessible after removing the housing cover)
Control display	Six green LEDs: 5 x input status, 1 x operating status

6.1.2 Device memory

Work, data & parameter memory	2 MB flash
Program memory	512 kB flash
Memory type	Ring buffer
Extreme values (max./min.)	Extreme values that occurred after connection to the power supply or after the extreme value memory has been deleted manually including date and time
Event memory	Memory size 1,500 events including date and time of their occurrence
Operation logbook	Memory size 500 events including date and time of their occurrence
Limit violation	Recording time ≥ 200 ms
Voltage dips of the measuring voltage	Recording time ≥ 20 ms; threshold can be set using the computer, value after reset 85% of rated voltage (according to EN 61000-4-30).

6.1.3 Power supply

Power supply	US1: 100–240 V ±10% DC/50/60 Hz
Power consumption	22 VA

6.1.4 Hardware inputs

Digital inputs	As pulse counter input 1 to 5	Digital input for floating contact, S ₀ -compatible, pulse length ≥ 30 ms, common minus
	As input status	Digital input, e.g. for floating contact, S ₀ -compatible with synchronization of measuring period; pulse length ≥ 250ms
	Voltage supply	27 V/15 mA DC internal

6.1.5 Electrical connection

Connection elements		Plug-in terminals
Max. permitted profile of the connecting cables		2.5 mm ²
Input power supply	Fuse	max. 1 A slow blow max. C2 automatic isolating switch UL/IEC-approved
KBR eBus Connection	Connection material	For proper operation, use shielded twisted-pair cables only; e.g. I-Y(St)Y 2x2x0.8
Pulse inputs	Wiring & cables	Observe correct polarity!
Synchronous input	Wiring & cables	Observe correct polarity!
KBR eBus Connection	via RS485	Terminal 90 (L) Terminal 91 (A) Terminal 92 (B)

6.1.6 Hardware outputs

Interface	Serial interface	RS 485 for connection to the KBR eBus; a maximum of 32 devices per bus segment, up to 1,000 m without bus repeater if placed suitably. For additional information, see KBR eBus installation guide.
	Transfer speed	38,400 baud
	Bus protocol	KBR eBus
	KBR eBus Address assignment	Can be addressed up to address 9999 with the software; scan mode can be activated on the device
Module bus interface	Serial interface	RS 485 (RJ12) for ready-made KBR system cable (six-pin modular cable, unshielded), max. length 30 m if placed suitably.
Display and configuration interface	Serial interface	RS485 (RJ12)
Relay outputs	Switching stages	Five relays
	Switching power	250 V (AC)/2 A per relay, potential depending on Common connection dependent – not safe to touch
Alarm relay	Switching power	Max. 250 V (AC)/2 A floating – not safe to touch

6.1.7 Mechanical data

DIN rail measuring device	Housing dimensions	90 x 106 x 61 mm (H x W x D),
	Mounting type	Wall mounting on DIN rail 7.5 mm deep, in accordance with DIN EN 50022
	Weight	Approx. 650 g

6.1.8 Dimensioned drawing

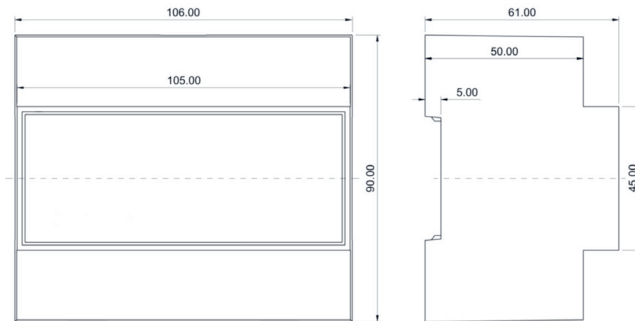

6.1.9 Surrounding conditions/electrical safety

Surrounding conditions	Standards	DIN EN 60721-3-3/A2: 1997-07; 3K5+3Z11; (IEC721-3-3; 3K5+3Z11)
	Operating temperature	K55 (-5 °C +55 °C)
	Air humidity	5% ... 95%, non-condensing
	Storage temperature	K55 (-25 °C +70 °C)
	Operating height	0...2,000 m above sea level
Electrical safety	Standards	DIN EN 61010-1: 2011-07
	Protection class	I
	Overvoltage category	CAT III
	Rated insulation voltage	4 kV
Protection type	Standards	IP20 in accordance with DIN EN 60529: 2014-09
EMC	Standards	DIN EN 61000-6-2:2006-03 + correction 1:2011-03 DIN EN 61000-6-3:2011-09 + correction 1:2012-11 DIN EN 61326-1:2013-07

6.1.10 Troubleshooting

No function.

Check power supply, back-up fuse and supply cable.

No display of the pulse inputs (flashing LEDs)

Check power supply. Check the correct connection of the input polarity.

6.2 Technical data of the display

6.2.1 Power supply

Power supply	ext. 24 V DC, 1 W, via RJ12 module bus connector
--------------	--

6.2.2 Hardware inputs and outputs

Serial interface	Module bus	RS485 via RJ12 interface
	Baud rate	38,400

6.2.3 Electrical connection

Module bus connection	Connection material	ready-made KBR system cable (six-pole modular cable, unshielded), max. length 30 m if placed accordingly
-----------------------	---------------------	--

6.2.4 Mechanical data

Switchboard installation	Housing dimensions	96 x 96 x 46 mm (H x W x D)
	Installation cut-out	92 x 92 mm
	Protection type	Front IP 40
	Weight	Approx. 175 g

6.2.5 Surrounding conditions/electrical safety

Surrounding conditions	Standards	DIN EN 60721-3-3/A2: 1997-07; 3K5+3Z11; (IEC721-3-3; 3K5+3Z11)
	Operating temperature	K55 (-5 °C +55 °C)
	Air humidity	5% ... 95%, non-condensing
	Storage temperature	K55 (-25 °C +70 °C)
	Operating height	0...2,000 m above sea level
Electrical safety (used with base device)	Standards	DIN EN 61010-1: 2011-07
	Protection class	I
	Overvoltage category	CAT III
	Rated insulation voltage	4 kV
Protection type	Standards	IP20 in accordance with DIN EN 60529: 2014-09
EMC	Standards	DIN EN 61000-6-2:2006-03 + correction 1:2011-03 DIN EN 61000-6-3:2011-09 + correction 1:2012-11 DIN EN 61326-1:2013-07



A series of 20 horizontal lines spaced evenly down the page, providing a template for handwritten notes.

24402_EDEBD0267-3724-1_EN



KBR GmbH

Am Kieferschlag 7
D-91126 Schwabach

T +49 (0) 9122 6373-0
F +49 (0) 9122 6373-83
E info@kbr.de

www.kbr.de