



## Quick guide Technical parameters

### MID-Counter

multicount D5-3P-75A-MID  
multicount D5-3P-1/5A-MID  
multicount D5-2-ES-75A-MID  
multicount D5-2-ES-3P-1/5A-MID



Disclaimer .....	5	Peak-Control / Threshold .....	19
safety instructions .....	5	Threshold .....	19
Product liability .....	9	Default settings ex-factory .....	19
disposal .....	9	Response time / release time .....	20
Menu navigation .....	10	Configuration of threshold .....	20
Commissioning / Check-up .....	10	Maximum active power: measurement period (only multicount D5-2-xxx-MID) .....	22
Technical data .....	11	Configuration of measurement period .....	22
Direct connection .....	12	Reset of maximum active power .....	22
Current transformer /5A und /1A .....	12	Start / synchronization measurement period .....	23
Installation instruction .....	12	Reset minimum and maximum values (only multicount D5-2-xxx-MID) .....	23
Cable requirement >65A .....	13	Reset power outages .....	24
Display Language .....	13	Reset of tariff register (only multicount D5-3P-xxx-MID) .....	24
Configure of display language .....	13	Reset tariff register .....	24
Bus interface KBR-eBus (only multicount D5-2-xxx-MID) .....	14	Error messages .....	25
Tariff control .....	14	Data backup / power failure .....	27
Current transformer ratio .....	15	Calibration pulse / calibration constant .....	27
Current transformer /5A .....	15	D0 interface according to EN 62056-21 .....	27
Current transformer /1A .....	16	Connection-diagram .....	28
Configuration of current transformer ratio .....	16		
S0 pulse-output .....	16		
Default settings ex-factory .....	17		
Configuration pulse rate .....	17		
Configuration of pulse length .....	18		
S0 pulse-output .....	18		
Rate per kWh / kvarh .....	18		
Length .....	18		

## Dear customer

Thank you for choosing a KBR product.

To familiarize yourself with the operation and configuration of the device, we recommend that you read this manual carefully. This will enable you to make use of the full range of functions that this high-quality product has to offer.

The individual chapters explain the technical details of the device and show you how to install and start it up properly to avoid damage.

This user manual is included in the scope of delivery of the device and must be accessible to the user at all times (e.g. in the switchgear cabinet). Even if the device is resold to third parties, the manual remains an inherent part of the device.

Although the utmost care has been taken in writing this user manual, errors may still occur. We would be very grateful if you would notify us of any errors or unclear descriptions you may notice.

Yours sincerely,

KBR GmbH Schwabach

This manual contains notes that must be observed for your personal safety and to prevent damage to the equipment. These notes are identified by a warning sign or information symbol, depending on the degree of hazard they warn about.



### **DANGEROUS VOLTAGE**

This means that death, serious physical injury or considerable property damage will occur if the appropriate safety precautions are not taken.



### **CAUTION**

This means that minor physical injury or property damage may occur if the appropriate safety precautions are not taken.



### **NOTE**

This is an important piece of information about the product, the handling of the product or the relevant part of the user manual to which particular attention should be drawn.

## DISCLAIMER

The contents of this document have been checked using the hardware and software described. However, deviations cannot be ruled out, meaning that no guarantee can be made for complete agreement. The information provided in this manual is checked on a regular basis; any corrections necessary will be included in the next revision.

We appreciate your corrections and comments.

## SAFETY INSTRUCTIONS

In order to prevent operating errors, handling of the device has been kept as simple as possible. This will enable you to start use the device quickly. Be sure to carefully read the following safety instructions.



## DANGEROUS VOLTAGE

### **The applicable DIN/VDE regulations must be observed during installation!**

Connection to the mains, commissioning and operation of the device may only be carried out by qualified personnel. Qualified personnel as defined in the safety instructions in this user manual are personnel with electrical engineering qualifications, knowledge of the national accident prevention regulations and safety engineering standards as well as of the installation, commissioning and operation of the device.

To prevent fire and electric shock, do not expose the device to rain or moisture!

Before connecting the device to the power supply, check whether the local power supply conditions comply with the specifications on the device nameplate.

Incorrect connection may result in the destruction of the device!

When connecting the device, adhere to the information given in the connection diagram (see “Connection diagram”) and that the connecting cables are not live. When wiring, always ensure that all cables used are neither damaged nor faulty and observe correct polarity!

To ensure proper and safe operation of the device, ensure that it is transported, stored, installed, assembled, and carefully operated and maintained in accordance with the specifications.

If the device has any visible damage it is considered unfit for use and must be disconnected from the power supply! Troubleshooting, repairs and maintenance work may only be carried out at our plant or after contacting our customer service team.

Unauthorized opening of the device will render your warranty null and void. Correct functioning can no longer be guaranteed!

Opening the device may expose live parts. Do not operate open devices under any circumstances!

All input and output cables of systems that are at risk from lightning strikes must be fitted with lightning protection.



## GEFÄHRLICHE SPANNUNG

The multicount D5-xxx-MID should only be used for measuring electrical energy and can not be operated outside the specified technical data.

When installing or replacing the meter, the conductor, to which the meter is connected, has to be dead (power / voltage off). Touching live (voltage or power) components is dangerous! Therefore, the appropriate fuses are to remove and secure. No body shall be able to turn voltage / power on without prior notification. Before opening / disconnect the clamps, short-circuit the secondary circuits of the current transformers. The resulting high voltage on the current transformer is extremely dangerous (dangerous to life) and could destroy the current transformer. The usual local security and work rules must be observed. The installation of the meter must be carried out by qualified and trained personnel.



## NOTE

Der multicount D5-xxx-MID is maintenance free. In case of damage (for example shipping, incorrect connection or storage) repairs may only be done by KBR GmbH.

## Product liability

### **You have purchased a high-quality product.**

Only components of the highest quality and maximum reliability are used.

Each device is subject to long-term testing before delivery.

For details on product liability, please refer to our general terms and conditions for electronic equipment.

The assured device properties only apply if the device has been operated in accordance with its intended use!

## DISPOSAL

Devices that are faulty, obsolete or no longer used must be properly disposed of.

If required, we will dispose of the device for you.

## MENU NAVIGATION

Blue  
key

Go to next unit  
Active energy, active power etc.

Red  
key

More information of unit  
E.g. phase L1, L2, L3, total, Min. / Max values

Yellow  
key

Service key, on the right side bellow the red terminal cover.  
To save a configuration, push the service key for 5 seconds.

## COMMISSIONING / CHECK-UP

### To check for operation:

- Phase rotation
- Current per phase
- Negative energy direction
- Sequence of phase (L1 L2 L3)
- For meter with CT's:
  - Current Transformer ratio
  - If present: remove the short circuit on the current transformer
- Terminal tightening torque
- Read-out interface: Correct address
- Neutral conductor connected

## TECHNICAL DATA

Nominal voltage $U_n$	3x230/400V (+/- 20%)
Accuracy class	B (1%)
Nominal frequency $f_n$	50Hz (60Hz on request)
Operating temperature	-25° C...+55° C
Storage temperature	-30° C...+70° C
Protection class	Clamps: IP20   Case: IP51
	Mechanical: M1   Electro-magnetic: E1
Safety class	2
Description	3-phase static Energy and Power Meter
EC-type examination	CH-MI003-13022
Maximal humidity	Janual average 75%, Short-term 95%, Non-condensing
Voltage path	0.8 VA / 0.8W per Phase
Current path	Meter 0.03 VA per Phase

## Direct connection

**Current** ( $I_{str}$ ,  $I_{min}$ ,  $I_{tr}$ ,  $I_{ref}$ ,  $I_{max}$ )

0.02 A / 0.25 A / 0.5 A / 5 A / 75 A (5(75))

## Current transformer /5A und /1A

**Current /5A** ( $I_{str}$ ,  $I_{min}$ ,  $I_{tr}$ ,  $I_{ref}$ ,  $I_{max}$ )

0.01 A / 0.05 A / 0.25 A / 5 A / 6 A (5(6))

**Current /1A** ( $I_{str}$ ,  $I_{min}$ ,  $I_{tr}$ ,  $I_{ref}$ ,  $I_{max}$ )

0.002 A / 0.01 A / 0.05 A / 1 A / 1.2 A (1(1.2))

## Installation instruction

### Torque

Connection Flexible wire	Direct max. 35mm <sup>2</sup> strand	Current transformer max. 6mm <sup>2</sup> strand
Input lead L1/L2/L3	2-3 Nm	1.3 - 1.6 Nm
Neutral conductor	2-3 Nm	1.3 - 1.6 Nm

S0 pulse output

0,4 Nm (max. 2.5mm<sup>2</sup> strand)

Tariff control

0,4 Nm (max. 2.5mm<sup>2</sup> strand)

## Cable requirement >65A

Type: Wire (Cu), cross-section: 35mm<sup>2</sup>,  
Outside-Ø 9,55 mm

## DISPLAY LANGUAGE

Display language can be selected between English and German (Deutsch).

### Configure of display language

For all device variants:

After connecting the voltage, the actual language will be shown on the display for about 10 seconds.

With the multicount D5-3P -xxx- MID, the language can also be changed in the settings:

- 1) Blue key to Adjustments
- 2) Red key to Language (Sprache)
- 3) Push Service-Key briefly
- 4) Adjust Language by blue key
- 5) Saving: Push Service key for 5 seconds, until the display stops to flash

**BUS INTERFACE KBR-EBUS** (only multicount D5-2-xxx-MID)

Upon delivery, the address corresponds to the last four digits of the serial number.

The address can only be changed via software (KBR eBus)

**TARIFF CONTROL**

Tariff changeover works with a 230V signal. Neutral cond. on clamp 5 (NE), outer cond. switched on clamp 3 (E3), respectively 4 (E4).

<b>Double-tariff</b>	
	E4
T1	0
T2	1

0 = no voltage

1 = voltage

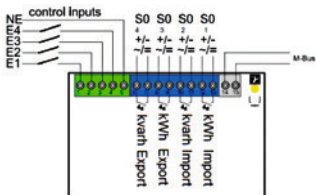

## CURRENT TRANSFORMER RATIO

Current transformer ratio can be adjusted from 5/5 to 20'000/5A and 1/1 to 4'000/1A

Left (blue) key = Change of digit / number

Right (red) key = Go to next digit / number

## Current transformer /5A

AABCC : 5A

AA adjustable in steps of 1

B adjustable in steps of 1

CC adjustable in steps of 5

## Current transformer /1A

YYYY : 1A

Y adjustable in steps of 1

## Configuration of current transformer ratio

- 1) Blue key to Transformer ratio
- 2) Push service key briefly
- 3) Adjust secondary current by blue key
- 4) Go to primary current by red key
- 5) Adjust first two digits by blue key
  - 6) Go to next digit by red key
  - 7) Adjust digit by blue key
  - 8) Go to next digit by red key.
  - 9) Adjust next two digits by blue key.
- 10) Saving: Push Service key for 5 seconds, until digits are not blinking

## S0 pulse-output

The four S0 pulse-outputs are designed according to EN62053-31 (DIN 83864). Pulse rate and pulse lengths can be configured by the keys.

## Default settings ex-factory

1. S0 Output = Active Energy Import (12+13)
2. S0 Output = Reactive Energy Import (10 + 11)
3. S0 Output = Active Energy Export (8 + 9)
4. S0 Output = Reactive Energy Export (6 + 7)

	<b>Direct conn.</b>	<b>CT</b>
Pulse rate	1000 Imp./kWh	10 Imp./kWh
Pulse length	40ms	120ms

The multicount D5-3P-xxx-MID only has one pulse-output for active energy import.

## Configuration pulse rate

- 1) Blue key to Adjustments
- 2) Red key to S0 Pulse Rate
- 3) Push service key briefly
- 4) Move decimal place by blue key Example 1000.000 = 1000 Impulse
- 5) Saving: Push Service key for 5 seconds, until digits are not blinking

## Configuration of pulse length

- 1) Blue key to Adjustments
- 2) Red key to S0 Pulse Duration
- 3) Push service key briefly
- 4) Adjust pulse length by blue key
- 5) Saving: Push Service key for 5 seconds, until digits are not blinking

## S0 pulse-output

Opto Power MOSFET

5 – 230 VAC or VDC, max. 90mA

## Rate per kWh / kvarh

0.001, 0.01, 0.1, 1, 10, 100, 1000, 10'000

## Length

Adjustable from 4 to 250 milliseconds in steps of 2 ms.

## PEAK-CONTROL / THRESHOLD

### Threshold

The following values can be chosen as a threshold:

- Active Power
- Reactive power
- Apparent power
- Current total
- Current per phase L1 / L2 / L3

Only one threshold can be defined for all 4 outputs. Only positive values are detected.

### Default settings ex-factory

Threshold: 5.000 kW

Status: Not active

## Response time / release time

The response and release time is adjustable between 0 and 9999 seconds.

Response time: Time, until contact switches

Release time: Time, until contact switches after threshold is not exceeded anymore.

The threshold function can be assigned to any output S0.

## Configuration of threshold

- 1) Blue key to Adjustments
- 2) Red key to Assignment Output X
- 3) Push service key briefly
- 4) Adjust to Threshold by blue key
- 5) Saving: Push Service key for 5 seconds, until digits are not blinking
- 6) Red key to Unit Threshold
- 7) Push service key briefly
- 8) Select desired unit by blue key
- 9) Next by red key
- 10) Adjust Threshold by blue key
- 11) Go to next digit by red key

- 12) Saving: Push Service key for 5 seconds, until digits are not blinking
- 13) Red key to Threshold Time till ON
- 14) Push service key briefly
- 15) Adjust digit by blue key
- 16) Go to next digit by red key
- 17) Saving: Push Service key for 5 seconds, until digits are not blinking
- 18) Red key to Threshold Time till OFF
- 19) Push service key briefly
- 20) Adjust digit by blue key
- 21) Go to next digit by red key
- 22) Saving: Push Service key for 5 seconds, until digits are not blinking

## MAXIMUM ACTIVE POWER: MEASUREMENT PERIOD

(only multicount D5-2-xxx-MID)

### Configuration of measurement period

- 1) Blue key to Adjustments
- 2) Red key to Measurement period
- 3) Push service key briefly
- 4) Adjust time by blue key
- 5) Saving: Push service key for 5 seconds

### Reset of maximum active power

- 1) Blue key to Reset Register
- 2) Red key to Max. Active Power
- 3) Push service key briefly
- 4) Set to RESET by blue key
- 5) Perform reset: Push service key for 5 seconds

### Start / synchronization measurement period

Synchronization takes place by using a 230VAC control signal.

In normal operation mode, voltage is connected to input E1, input E2 is dead (without voltage).

To start a new measurement period, disconnect voltage from E1 and connect voltage to E2.

For security reasons a voltage change has to take place at both inputs E1 and E2.

### Normal mode

E1

E2

1

0

0 = No voltage

1 = Voltage

### Start new measurement

E1

E2

0

1

## RESET MINIMUM AND MAXIMUM VALUES

(only multicount D5-2-xxx-MID)

- 1) Blue key to Reset Register
- 2) Red key to Min/Max Register
- 3) Push service key briefly
- 4) Set to RESET by blue key
- 5) Perform reset: Push service key for 5 seconds

## Reset power outages

- 1) Blue key to Reset
- 2) Red key to Power outages
- 3) Push service key briefly
- 4) Set to RESET by blue key

5) Perform reset: Push service key for 5 seconds

### **RESET OF TARIFF REGISTER** (only multicount D5-3P-xxx-MID)

The multicount has a resettable tariff register. The resettable register is indicated by and arrow above the unit (kWh).

#### **Reset tariff register**

- 1) Blue key to Reset Register
- 2) Red key to Active energy NO RESET
- 3) Push service key briefly
- 4) Set to RESET by blue key
- 5) Perform reset: Push service key for 5 seconds

## ERROR MESSAGES

If an internal error appears, an error message is displayed.

F.F.0(00000000)	No error, meter ok
F.F.0(xxxxxxx0)	Meter calibrated
F.F.0(xxxxxxx1)	Meter not calibrated
F.F.0(xxxxxxx8)	Calibration release, meter is calibrated and can be re-calibrated.
F.F.0(xxxxxxx9)	Calibration release, meter is not calibrate and can be calibrated now.
F.F.0(xxxxxxxF)	Meter initializes again. Default parameters are loaded
F.F.0(xxxxxx0x)	Meter in normal mode
F.F.0(xxxxxx1x)	Meter in service mode
F.F.0(xxxxxx0xx)	Checksum Micro FLASH and EEPROM OK
F.F.0(xxxxxx1xx)	Error in checksum Micro FLASH
F.F.0(xxxxxx2xx)	Error in checksum EEPROM
F.F.0(xxxxxx3xx)	Error in checksum FLASH and EEPROM
F.F.0(xxxxx0xxx)	Micro RAM and STACK OK

F.F.0(xxxx1xxx)	Error checksum Micro RAM.
F.F.0(xxxx2xxx)	Error Micro STACK (Overflow).
F.F.0(xxxx3xxx)	Error checksum Micro RAM and Error Micro STACK.
F.F.0(xxx0xxxx)	Micro OK
F.F.0(xxx1xxxx)	Error in Micro
F.F.0(xx0xxxxx)	Hardware OK
F.F.0(xx1xxxxx)	Hardware Error
F.F.0(x0xxxxxx)	Real Time Clock (RTC) OK
F.F.0(x1xxxxxx)	Error in Real Time Clock
F.F.0(0xxxxxxx)	Real Time Clock set
F.F.0(1xxxxxxx)	Real Time Clock default datum / time

## DATA BACKUP / POWER FAILURE

To prevent data loss in case of power failure, all relevant data are stored in non-volatile EEPROM. This takes place if voltage is falling below a defined level. Also automatically every 24 hours to save all relevant data in non-volatile EEPROM.

## CALIBRATION PULSE / CALIBRATION CONSTANT

The red LED on the front is proportional to the active power.

The pulse constant is 10 Imp./Wh

The pulse duration is 2msec.

Pulses are sent for energy direction import and export

## D0 INTERFACE ACCORDING TO EN 62056-21

The D0 (optical) interface is located on the front, right next to the display.

The multicount D5-xxx-MID have a serial D0 interface according to EN 62056-21. The D0 interface can be configured as bidirectional (Mode A or C) or as a unidirectional (D0 mode) communication interface.

## CONNECTION-DIAGRAM

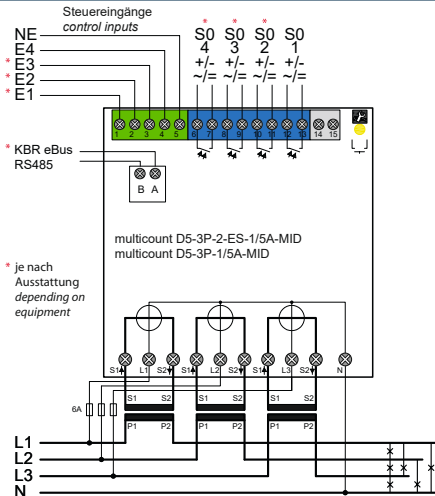

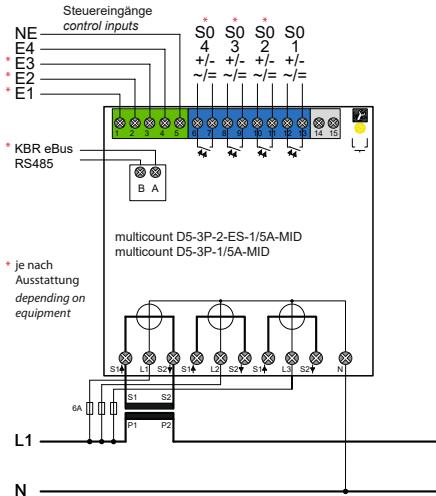

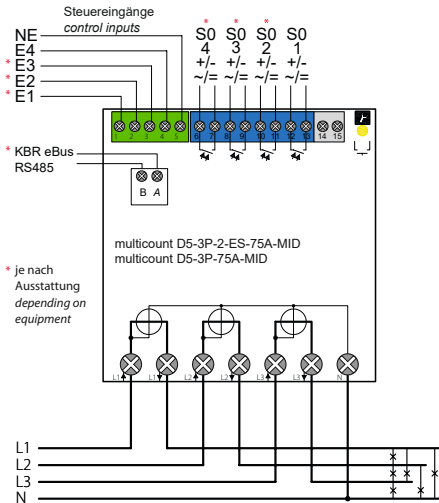

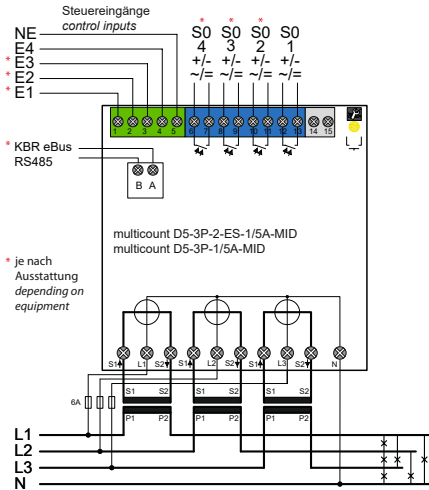

## **KBR GmbH**

Am Kiefernschlag 7  
D-91126 Schwabach

T +49 (0) 9122 6373-0  
F +49 (0) 9122 6373-83  
E [info@kbr.de](mailto:info@kbr.de)

**[www.kbr.de](http://www.kbr.de)**