

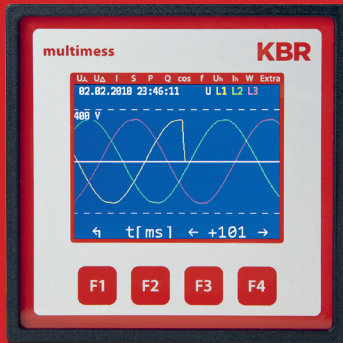

# User Manual Technical Parameters



## multimes F96 TFT-xxx-5 Rogowski

26416\_EDEBD00296-3724-1\_EN

System | englisch



In our download centre you will find the appropriate instructions for KBR devices.  
<https://www.kbr.de/en/download/operating-instructions/>

KBR GmbH does not accept any liability for any loss or damage resulting from printing errors in or changes to this manual.

In addition, KBR GmbH does not accept any liability for any loss or damage caused by defective devices or devices manipulated by the user.

Copyright 2021 by KBR GmbH

Subject to change.

## Table of contents

1	Introduction .....	6
1.1	User manual .....	6
1.2	Intended use .....	6
1.4	Safety notes .....	9
1.5	Product liability .....	10
1.6	Disposal .....	10
2	Range of functions.....	10
2.1	Note for devices with TCP / IP - LAN port .....	11
3	Device overview .....	13
3.1	Operating structure.....	13
4	Installation .....	16
4.1	Device assembly .....	16
4.1.1	Rotary field.....	17
4.1.2	Asymmetry .....	17
4.1.3	Current transformer connection.....	18
4.1.4	Note on the Rogowski current measuring tapes.....	18
4.2	Connection diagram .....	19
4.3	Terminal assignment.....	21
4.4	Buffered long-term memory .....	22
5	System operation .....	23
5.1	Control and display panel .....	23
5.1.1	Description of buttons and displays .....	24
5.2	Setting range .....	25
5.3	Basic device configuration.....	26
5.3.1	Setting the limits .....	26
6	Menu overview .....	29
6.1	Main menu $U_{ph-n}$ voltage.....	29
6.2	Main menu $U_{ph-ph}$ voltage.....	29
6.3	Main menu I current.....	30
6.3.1	Submenu $I_m$ current average .....	30
6.3.2	Submenu $I_n$ neutral conductor current .....	30
6.3.3	Submenu $I_n$ average neutral conductor current.....	31

6.4	Main menu S apparent power .....	31
6.4.1	Submenu PQS display of totals for active, reactive and apparent power.....	31
6.5	Main menu P active power: .....	32
6.5.1	Submenu PQS display of totals for apparent, active and reactive power .....	32
6.6	Main menu Q reactive power (fundamental).....	32
6.6.1	Submenu PQS display of totals for apparent, active and reactive power .....	32
6.7	Instantaneous value Cos Phi .....	33
6.7.1	Submenu power factor .....	33
6.7.2	Submenu totals of power factors .....	33
6.8	Main menu F frequency .....	34
6.9	Main menu Uhvoltage distortion factor .....	35
6.9.1	Submenu 3rd harm. U .....	35
6.10.1	Submenu 3rd harm. I .....	36
6.11	Main menu W - active and reactive energy / consumption and recovery .....	37
6.11.1	Submenu W active energy low tariff consumption .....	37
6.11.2	Submenu W reactive energy high tariff consumption .....	37
6.11.3	Submenu W reactive energy low tariff consumption .....	38
6.11.4	Submenu W active energy high tariff recovery.....	38
6.11.5	Submenu W active energy low tariff recovery.....	38
6.11.6	Submenu W reactive energy high tariff recovery.....	39
6.11.7	Submenu W reactive energy low tariff recovery.....	39
6.12	Main menu Extra .....	40
6.12.1	Setting transformer ratio .....	41
6.12.2	Time and bus communication.....	41
6.12.3	Set display and attenuation coefficient .....	41
6.12.4	Set language and pulse output .....	42
6.12.5	Configure relay outputs .....	42
6.12.6	Password and reset.....	42
6.12.7	Zero-point creator.....	43
6.13	Reset to default settings.....	44
7	Modbus interface .....	45
7.1	Description Modbus interface for Modbus RTU or ASCII.....	45
7.1.1	Change bus protocol .....	45
7.2	Ethernet interface for Modbus TCP.....	48

7.2.1	Change bus paramters .....	48
7.3	Modbus TCP configuration (software configuration).....	49
8	Ethernet interface for eBus TCP .....	51
8.1.	Change bus protocol .....	51
8.2	KBR eBus TCP configuration using the display .....	53
8.3	KBR eBus TCP configuration (software configuration).....	53
8.3.1	Assigning an IP Address to a Device of which the Address is Not in the Address Range of the Network. I .....	54
8.3.2	E-port Configuration for eBus TCP .....	55
9	Technical data in multimes F96 TFT-...-5.....	57
9.1	Measuring and display values .....	57
9.2	Measurement accuracy class (in accordance with DIN EN 61557-12).59	
9.3	Measuring principle .....	59
9.4	Device memory .....	60
9.5	Power supply .....	60
9.6	Hardware inputs and outputs.....	61
9.6.1	Hardware inputs .....	61
9.6.2	Hardware outputs .....	61
9.7	Electrical connection.....	62
9.8	Mechanical data.....	62
9.9	Standards and miscellaneous .....	63
9.10	Default settings after a reset (delivery state) .....	64

# 1 Introduction

Thank you for choosing this KBR quality product.

To become familiar with the operation and programming of the device and to use the full range of functions of this high-quality product at all times, you should read this user manual carefully.

The individual chapters explain the technical details of the device and show how damage can be avoided through proper installation and commissioning.

## 1.1 User manual

This user manual describes the device version multimes-F96 TFT-xxx-5. This user manual must be accessible to the user at all times (e.g. in the switchgear cabinet). Even if the device is resold to third parties, the manual remains an inherent part of the device.

Although the utmost care has been taken in writing this user manual, errors may still occur. We would be very grateful if you would notify us of any errors or unclear descriptions you may notice.

## 1.2 Intended use

This device serves for the monitoring of all important parameters in a three-phase network.

In addition to the Basic version multimes F96-TFT-0-xxx-5, you can choose from additional device versions with extended interface and storage capacity. For a detailed description, see the following section.

Note that the device does not replace close monitoring of the respective parameters by the operator.

**NOTE**

The multimess F96-TFT-xxx-5 is available with different optional boards. Thus, this user manual describes all options possible. To see which device version you have, please refer to the nameplate.

- **Option 0:**  
no optional board
- **Option 1:**  
optional board with Modbus RS485, 2x relay outputs
- **Option 2:**  
not in use
- **Option 3:**  
optional board with KBR eBus RS485, Modbus RS485
- **Option 4:**  
optional board with Modbus Ethernet, 2x relay outputs
- **Option 5:**  
optional board with Profibus DP
- **Option 6:**  
optional board with KBR eBus Ethernet, 2x relay outputs
- **Option 7:**  
optional board with KBR eBus RS485, Modbus RS485, 2x relay outputs
- **Option 8:**  
optional board with KBR eBus RS485, KBR eBus TCP/IP, 2x relay outputs

### 1.3 Safety keys

This manual contains instructions that you must follow for your personal safety and to avoid material damage. These instructions are identified by a warning sign or information symbol, depending on the degree of hazard they warn about.



#### DANGEROUS VOLTAGE

„Warning“ means that death, major injuries or damage may occur if suitable safety precautions are not taken..



#### CAUTION

“Caution“ means that minor injuries or damage may occur if the appropriate safety precautions are not taken.



#### NOTE

„Note“ is an important piece of information on the product, its operation or the respective part of the user manual to which special reference is being made.

### Disclaimer

The contents of these ouser manual have been carefully reviewed in terms of the hardware and software described. However, deviations cannot be excluded and therefore complete conformity cannot be guaranteed. The specifications made in this user manual are reviewed on a regular basis; any corrections required will be included in the next revision.

## 1.4 Safety notes

In order to prevent operating errors, device operation is kept as simple as possible. This will enable you to start your device up quickly.

It is in your own interest to read the following safety instructions carefully. The applicable DIN/VDE regulations must be observed during installation!

Power supply connection, setup and operation of the device must be performed by qualified personnel only. Qualified personnel as defined in the safety notes in this user manual are those authorized to set up, ground and mark devices, systems and circuits in accordance with applicable standards and regulations.

To prevent fire and electric shock, do not expose the device to rain or moisture!

Before connecting the device to the power supply, check whether the local power supply conditions comply with the specifications on the device nameplate.



### CAUTION

Incorrectly connecting the device can damage it.

For device connection, the data given in the connection diagram must be complied with (see chapter “Connection diagram”) and the connection lines must be voltage-free. When wiring, always ensure that all wiring material used is neither damaged nor defective and that the polarity is correct!

Proper and safe operation of the product requires correct transport, storage, installation and assembly as well as careful operation and maintenance.

If the device has any visible damage it is considered unfit for use and must be disconnected from the mains!

Troubleshooting, repairs and maintenance work may only be carried out at our plant or after contacting our customer service team. If the device is opened without authorization, any warranty or guarantee claim is forfeited. Correct functioning can no longer be guaranteed!

Opening the device may expose live parts. Capacitors in the device may still be charged, even if the device has been disconnected from all power sources. Do not operate open devices under any circumstances!

Systems that are at risk from lightning strikes must feature lightning protection for all input and output lines.

## 1.5 Product liability

You have purchased a high-quality product. Only top-quality components with exceptional reliability are used.

Each device undergoes a long-term test before delivery.

With regard to product liability, please see our general terms and conditions for electronic devices, which you can read at [www.kbr.de](http://www.kbr.de).

The warranty on device characteristics only applies if the device is operated in accordance with its intended use!

## 1.6 Disposal

Please dispose of defective, out-of-date or no longer used devices properly. If required, we will dispose of the device for you.

## 2 Range of functions

The electronic network measuring devices of the multimes F96 TFT-xxx-5 measure and monitor all important parameters in a three-phase network and are available in different versions. All device versions are equipped with a pulse output.

Aside from the F96 TFT-0-xxx-5 entry level model, the load profile (P+ P- / Q+ Q-) can be saved with all device versions and later read out via KBR eBus. Network voltage can be monitored in accordance with EN 61000-T4-30. In case of a violation, the voltage and current history is saved and can be analyzed on the LCD display. Different optional interfaces and protocols allow various applications.

## 2.1 Note for devices with TCP / IP - LAN port

This device is also available in a version with a LAN port.

For this version, two options are provided for parameterizing the LAN port:

1. Using the IOT program [www.hi-flying.com/download-center-1/applications-1/download-item-iotservice](http://www.hi-flying.com/download-center-1/applications-1/download-item-iotservice) (source of supply).

First the IOT service tool should be installed. After starting the IOT service tool, the connected network is scanned and the reports found are displayed.

2. Using a web browser and the web interface in the LAN port.

The connected device then reports under the factory-set IP address **192.168.0.1**:



### NOTE

For security reasons, the IP address of the device should be changed immediately to prevent unauthorized access to the device from outside.

In addition, the device should be password-protected (for devices of the multimess series).

The device then reports with the following dialog window, in which the first parameterizations can be made:

Status System running overview	
<b>System State</b>	
Product Name E20	MAC FOF6BBAJD42
DHCP Disable	IP 192.168.0.1
Subnet mask 255.255.255.0	Gateway 0.0.0.0
DNS 0.0.0.0	Firmware Version 1.20
System Time NTP Disabled	Total Running Time 0-Day 1:23:1
Remaining RAM 27576	Max Block Size 26120
Configuration Protected Disable	
<b>Serial Port State</b>	
Receivd Bytes 3	Received Frames 1
Sent Bytes 0	Sent Frames 0
Failed Bytes 0	Failed Frames 0
Config 38400,8,1,EVEN	
<b>Communication State - 'netp'</b>	
Received Bytes 0	Received Frames 0
Sent Bytes 0	Sent Frames 0
Failed Bytes 0	Failed Frames 0
Protocol TCP-Server	State Server Created
Client IP	

The device then reports with the following dialog window, in which the first parameterizations can be made: Further settings can then be made on the following pages.

### System Settings

Change the device system settings

#### Authentication

User name	admin
Password	••••

#### Basic Settings

Host Name	mmses_et_BA1D42
Network Mode	Router

#### WiFi Settings

##### Basic Settings

Host Name	<input type="checkbox"/> OFF
WAN IP	192.168.0.1
Subnet mask	255.255.255.0
Gateway	0.0.0.0
DNS	0.0.0.0

##### LAN Settings

LAN IP	<input type="text" value="LAN IP"/> <small>The LAN IP field is required.</small>
Mask	<input type="text" value="Mask"/> <small>The Mask field is required.</small>
DHCP Server	<input type="checkbox"/> OFF

##### Telnet Settings

Enable	<input checked="" type="checkbox"/> ON
Telnet Port	23
Echo	<input type="checkbox"/> OFF

##### Web Settings

Enable	<input checked="" type="checkbox"/> ON
Web Port	80

##### NTP Settings

Enable	<input type="checkbox"/> OFF
--------	------------------------------

The user name (User) and the password for System Settings are factory-set to:

- Username: admin
- Password: admin
- „Flow Control: Half-Duplex“ controls the switching of the RS485 module.
- The web port must be set to 8000.
- UART Protokoll ist für eBus-TCP auf „NONE“ einzustellen
- Gap Time should be set to 10 (ms)  
(Waiting time after serial reception until telex is sent over the network).
- Cli Waiting Time should be set to a maximum of 15 (seconds).

26416\_EDEBDA0296-3724-1\_EN

12

V5.00

### 3 Device overview

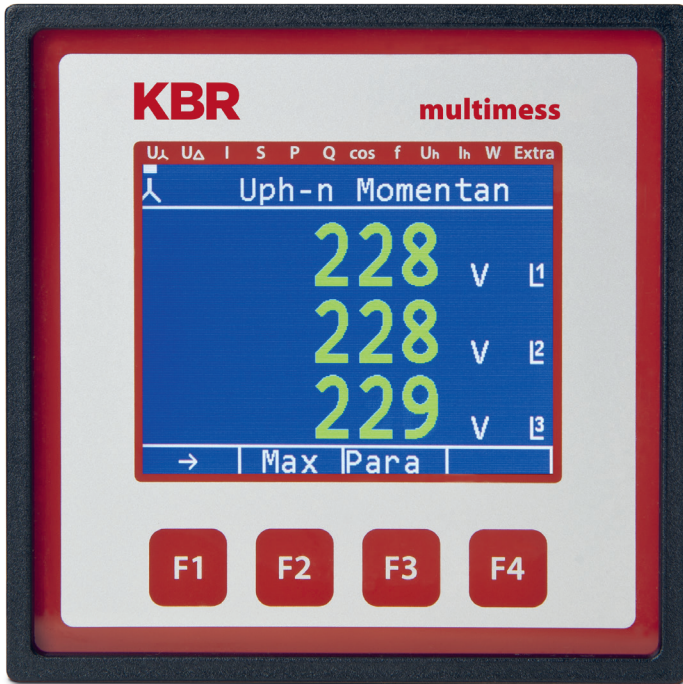

#### 3.1 Operating structure

The following overview shows the operating structure at a glance. For a more detailed insight, please read „Menu overview“.

sub menus

main menus

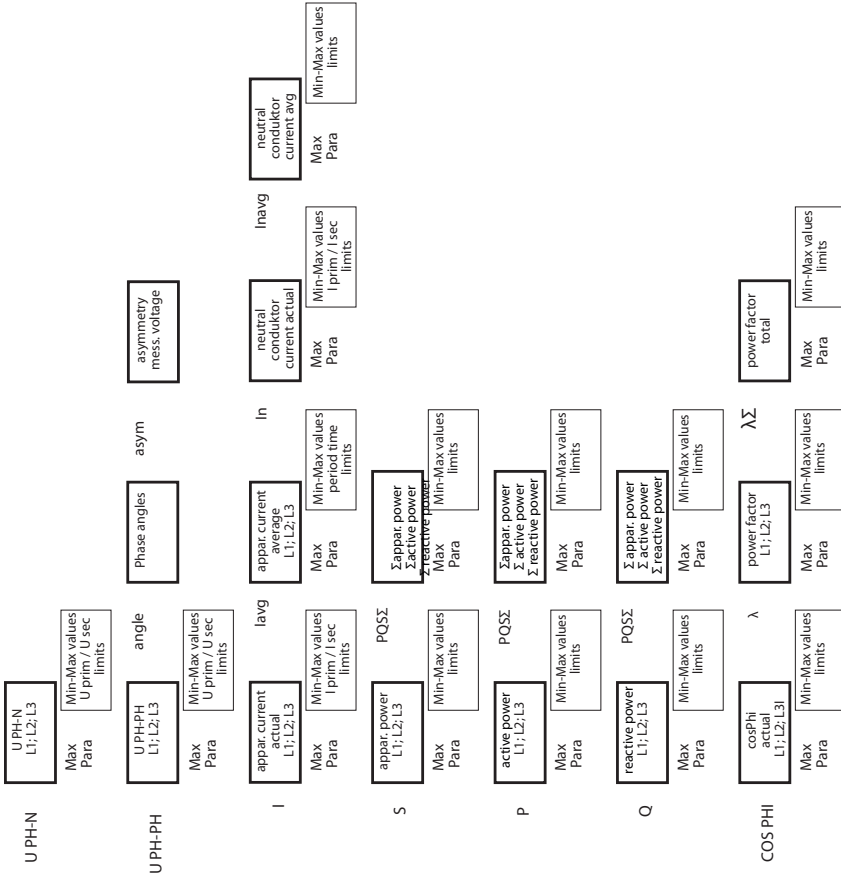

26416\_EDBD A0296-3724-1\_EN

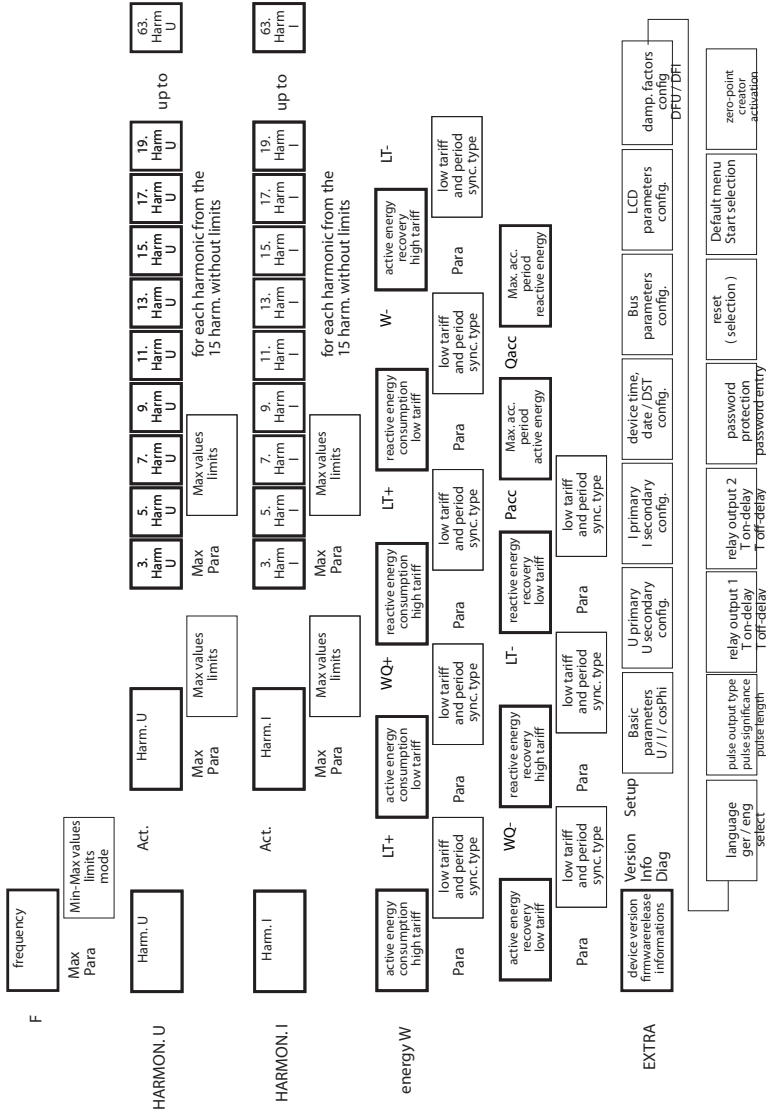

## 4 Installation

This chapter describes:

- „Device assembly“
- „Connection diagram“
- „Terminal assignment“
- „Buffered long-term memory“

### 4.1 Device assembly

The applicable VDE regulations must be observed during installation! Before the device is connected to the power supply, check whether the local power supply conditions comply with the specifications on the nameplate. Incorrect connection may result in the destruction of the device. A different mains frequency can also affect the measurement.

The device must be connected in accordance with the connection diagram.

The power supply input of systems that are at risk from lightning strikes must be equipped with suitable lightning protection.



#### CAUTION

The control voltage as well as the applied measuring voltage of the device must be protected using a back-up fuse. When connecting the current transformer, the energy flow direction and the correct assignment to the voltage path must be observed.

For the wiring of the pulse output, we recommend to exclusively use shielded twisted pair material, to avoid disturbance (e.g. installation line I-Y(ST) Y 2x2x0.8mm, whereas the shielding may only be connected on one side).

During installation, please also observe our safety instructions to protect against overvoltage and lightning in the „Protective measures“ chapter of this manual.



#### NOTE

The following points must be taken into account when connecting the device to the three-phase network you want to be measured:

- Direction of energy flow
- Assignment of measuring voltage input/current transformer input

### 4.1.1 Rotary field

The device can be operated with a clockwise or anti-clockwise rotary field. When mains to the device is switched on, the multimeter F96 TFT-xxx-5 automatically checks the direction of rotation. Rotary field check:

1. Connect only the measuring voltage to the device (U<sub>meas</sub> see nameplate).
2. Switch the device on by connecting the power supply cable voltage to the power supply connections (L and N). The device checks the mains direction of rotation immediately after being switched on.
3. The rotary field is displayed in the menu UPH-PH, submenu Angle.
4. For a clockwise rotary field, the display shows L1 0, L2 120 and L3 240 degrees.
5. If you want to change the direction of rotation from clockwise to anti-clockwise, simply swap two terminals, i.e. two phases, then switch the device OFF and ON again. The display now shows the correct voltage and the device starts measuring automatically.
6. Then, check again whether the assignment of voltage path L1 and current path L1, as well as for all other phases, is still correct.

### 4.1.2 Asymmetry

The rotary field is displayed in the menu U<sub>PH-PHr</sub>, submenu Angle / A<sub>sym</sub>.

The voltage asymmetry is displayed according to standard EN 6100-4-30:2003.

Shows the asymmetric load of the three phase network.

The display Asymmetry is shown and the value is displayed in %.

### 4.1.3 Current transformer connection

#### ■ Direction of energy flow

When inserting the Rogowski current measuring tapes, pay attention to the direction of current flow. If the current measuring tapes are inserted the wrong way, you will receive a negative sign in front of the displayed measured value. The prerequisite for this is that energy supply is present.

#### ■ Assigning the measuring voltage input/current transformer input

The current measuring strips at terminals 20/21/22 [1 + / 1- / ground] must be in phase from which the measuring voltage for terminal 10 [L1] is tapped.

The same applies to the other transformer and measuring voltage connections.

You can check the phase sequence as follows using the multimes F96 TFT-xxx-5:

1. Go to the main menu "I".
2. Connect the current transformer to the corresponding wires.
3. If the connection and direction of energy flow are correct, the device will only display positive currents.
4. If the device is connected incorrectly, all currents displayed will be negative.



#### CAUTION

Before any interchanging, the current transformers must be shorted out!

### 4.1.4 Note on the Rogowski current measuring tapes

The following Rogowski coils are available:

**Rogowski Coil 1:** Standard Algodue MFC190 // 35cm length // Imprint 1kA / 333mV à our use: 1kA / 333mV // Setting on the device: I primary = 1000A // I secondary = 333mVRogowski

**Rogowski Coil 2:** Standard Algodue MFC150 // 60cm length // Imprint 1kA / 100mV à our use: 3.33kA / 333mV // Setting on the device: I primary = 3330A // I secondary = 333mV



#### NOTE

1/5 of the value can be set for both coils (high gain).

Coil 1: I primary = 200A // I secondary = 66.7mV

Coil 2: I primary = 667A // I secondary = 66.7mV

The current measuring strips at terminals 20/21/22 [1 + / 1- / ground] must be in phase from which the measuring voltage for terminal 10 [L1] is tapped.

The same applies to the remaining current measuring tapes and measuring voltage connections. The phase sequence can be changed using the multimes F96 TFT-xxx-5 as follows: check:

## 4.2 Connection diagram

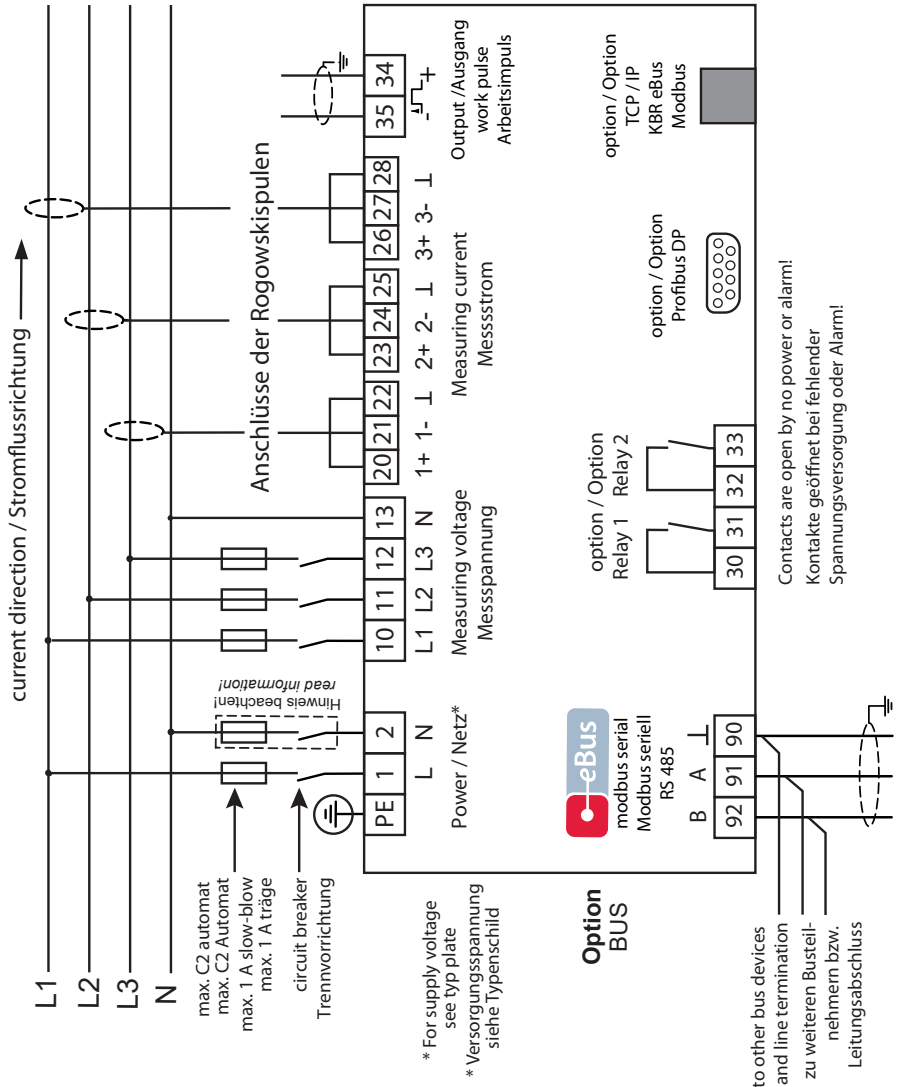



**NOTES**

**Mains connection with fuses:**

When connecting phase (L1) to terminal 1 and neutral conductor (N) to terminal 2 (Ph-N 100V - 240V +/- 10% 50Hz / 60 Hz / DC), the fuse and the isolator are in the supply line to terminal 2 ( N) not required.

The fuse and the isolator at connection terminal 2 (N) are only required for the following connection variants:

**AC voltage:**

Terminal 1 (L1) and Terminal 2 (L2):

US1 phase-phase 100V - 240V +/- 10% 50Hz / 60 Hz

**DC voltage:**

Terminal 1 (+) and Terminal 2 (-):

US1 100V - 240V +/- 10% DC

**Connection variants of the supply voltage**

Terminal 1	Terminal2	Voltage	Fuse and isolator required on terminal 2
		Power Supply US1	
Phase L	Neutral conductor N	100V - 240V +/-10% AC 50/60 Hz	No
Phase L1	Phase L2	100V - 240V +/-10% AC 50/60 Hz	Yes
+	-	100V - 240V +/-10% DC	Yes

### 4.3 Terminal assignment

Terminals 1 (L) and 2 (N):	<p><b>Power supply connection</b></p> <p>A control voltage is required to supply the device with power.</p> <p>The device has a multi-range power supply unit and can be supplied with different selectable voltages (see nameplate).</p>
Terminal 10 (L1): Terminal 11 (L2): Terminal 12 (L3): Terminal 13 (N):	<p><b>Voltage measuring input</b></p> <p>Three-phase voltage measurement in three-wire as well as four-wire rotary current networks. Direct measurement for 3x5...100...120V or 3x20...500...600VAC</p> <p>The measuring range is configurable. If the measuring range is exceeded, an error message is displayed.</p> <p>For higher voltages, the device needs to be connected via a voltage transformer. For IT networks, a zero-point creator is required.</p>
Terminal 20 (1+), Terminal 21 (1-) und Terminal 22 (ground) Terminal 23 (2+), Terminal 24 (2-) und Terminal 25 (ground) Terminal 26 (3+), Terminal 27 (3-) und Terminal 28 (ground)	<p><b>Current measurement inputs</b></p> <p>The measuring inputs for current are connected via the enclosed Rogowski current measurement coils.</p> <p>When connecting the current measuring coils, pay attention of the correct assignment of the measuring voltage inputs and the measuring coils!</p>
Terminal 30 und 31:	<p><b>Floating relay contact relay 1</b></p> <p>This contact serves as a message or alarm output. During operation, an acoustic or visual message can be activated or a consumer switched off using this relay. The contact is open as long as the device is dead as well as when there is an active message. Maximum switching capacity 2A at 250V AC.</p>
Terminal 32 und 33:	<p><b>Floating relay contact relay 2</b></p> <p>Refer to the description of the floating relay contact relay 1</p>

Terminal 34 (+) and 35 (-):	<p><b>Pulse output</b></p> <p>Output of energy-proportional pulses via a digital contact (S0 interface in accordance with DIN 43864). Ensure that the output has the right polarity. The output signals can be processed by a maximum demand monitor or a master central process control, for example.</p>
Terminal 90 (ground): Terminal 91 (A): Terminal 92 (B):	<p><b>Interface connection</b></p> <p>For communication on the KBR eBus or Modbus</p>

#### 4.4 Buffered long-term memory

The device is equipped with internal data memory (flash). After an uninterrupted charging time (device connected to the supply voltage) of approx. 100 hours, the buffer capacitor will have a sufficient charge to protect the internal clock from failure due to lack of operating voltage for approx. 7 days.



#### CAUTION

If the buffer capacitor is discharged and it is not connected to a power source, the time settings will be lost and will need to be reset!

## 5 System operation

In this chapter, you will find instructions on how to operate the multimes F96 TFT-xxx-5 in daily use. Furthermore, it contains references to the complete range of functions.

### 5.1 Control and display panel

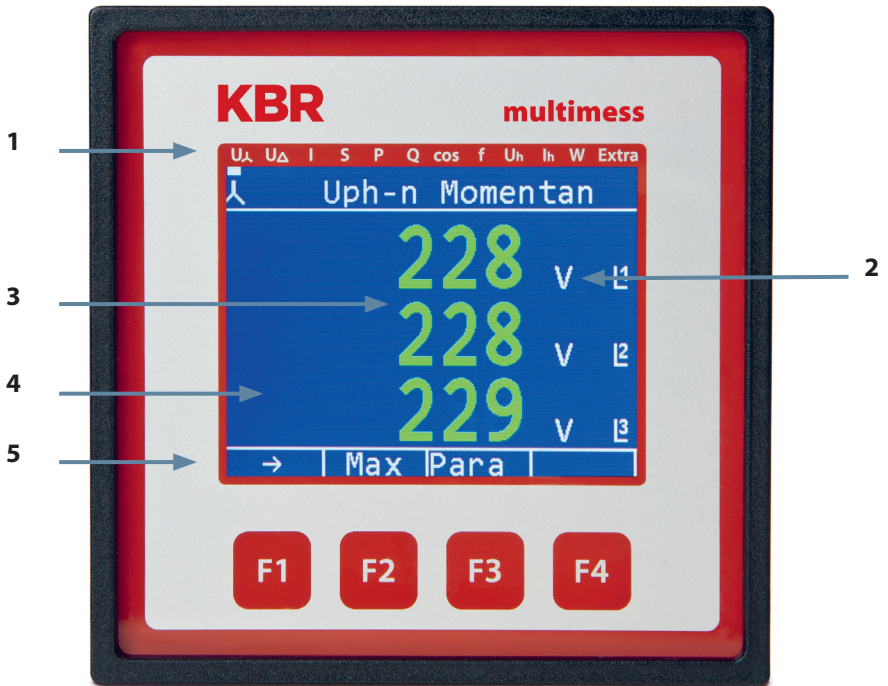

## **5.1.1 Description of buttons and displays**

### **1 Display navigation panel**

The navigation panel shows the main menu selected, considerably simplifying operation of the device. The operator can immediately see what menu he is in.

### **2 Unit display**

The unit display is normally used to show measured values. Each phase has its own display. In some submenus, this display area is used to show additional information to assist operation.

### **3 Measuring range**

These displays are used to represent measured, stored and programmed values. In some submenus, they are also used to simplify configuration with simple text output.

### **4 Additional information area**

Additional information is conveyed with simple and self-explanatory icons. This additional information makes it easier for the operator to interpret the recorded values.

### **5 Hot key area**

The text line corresponds to the button keys lying below it and is used to issue messages and text. The interaction between key and corresponding display ensures user-friendly and self-explanatory operation.

## 5.2 Setting range

The following setting ranges are available for configuration of the unit:

Measuring voltage, primary	1 V to 9999 kV
Measuring voltage, secondary	100 V to 500 V
Measuring current, primary	1A to 99.99 kA
Measuring current, secondary	333mV or 66,6mV
Limits	depending on the configured transformer values
Current average time	1 to 15 minutes
Limits Cosφ	inductive 0.00 to capacitive 0.00
Frequency correction	Automatic - 50 Hz - 60 Hz
Limits frequency	00.00 Hz to 65 Hz
Limits voltage harmonics	00.0% to 99.9%
Limits current harmonics	0 to 300 A
Attenuation coefficient voltage (display)	0 to 6
Attenuation coefficient current (display)	0 to 6
Working pulse output	Active and reactive energy 0.001 to 9990 pulses per KWH or kvar
Energy pulse duration	30 to 990 milliseconds
Signaling relay ON-delay	0 to 254 seconds
Signaling relay shutdown delay	0 to 254 seconds
Measurement period synchronization	Internal, KBR eBus, for tariff switching
Tariff switching	Internal, KBR eBus

### 5.3 Basic device configuration

The menu navigation of the multimess F96 TFT-xxx-5 is self-explanatory.

The operator is guided and supported by the device through operating instructions displayed for the respective situation.

As an example of the basic procedure of programming, the functions in the U Phase - N menu will be looked at more closely.

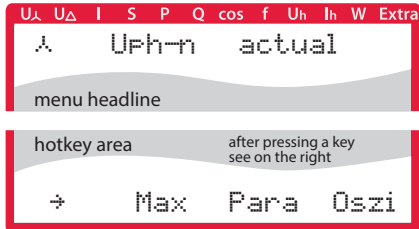

- F1** Scroll through main menu
- F2** Display and processing of minimum and maximum values
- F3** Entry for configuration => limits and voltage transformer



#### 5.3.1 Setting the limits

After pressing the **F3** (Para) button, the following is displayed in the hotkey area:

##### Menu: U phase - N

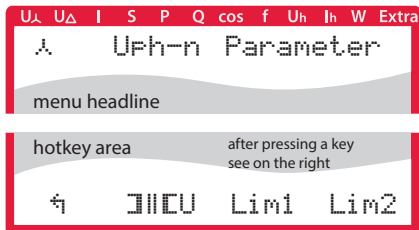

- F1** Return
- F2** Display and processing for voltage transformer
- F3** Configuration limit 1
- F4** Configuration limit 2



After pressing the **F3** (GW1) button, the following display appears in the hot key area of the display:

### Menu: U Phase - N

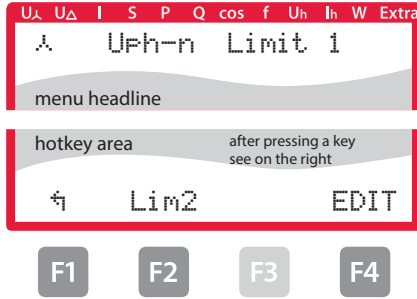

- F1** Rücksprung
- F2** Wechsel zur Bearbeitung Grenzwert 2
- F3** Hysterese für Grenzwert 1 bzw. 2
- F4** Parametrieren Grenzwert 1

After pressing the **F4** (Edit) button, the following is displayed in the hot key area:

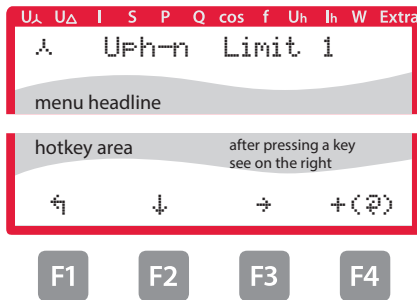

- F1** Return
- F2** Scroll through lines in the value range
- F3** Continue to next digit
- F4** + Value input (⊗ function selection)

If the setting was changed, the following display appears after the third line in the hot key area of the display if the **↓** (key (scrolling function) is pressed::

### Menu: U Phase - N

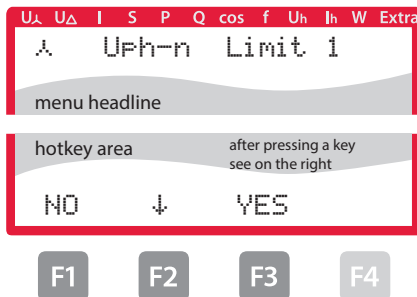

- F1** Leave setting menu without saving
- F2** Scroll through lines in the value range
- F3** Leave settings menu and save

After pressing the **F3** (EDIT) button, the following is displayed in the hot key area:

**Menu: U Phase - N**

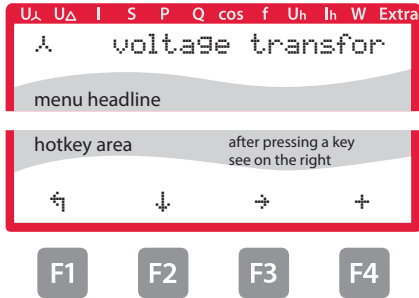

- F1** Return
- F2** Scroll through lines in the value range
- F3** Continue to next digit
- F4** + Value input

If the setting was changed, the following display appears after the third line in the hot key area of the display if the **F3** key (scrolling function) is pressed:

**Menu: U Phase - N**

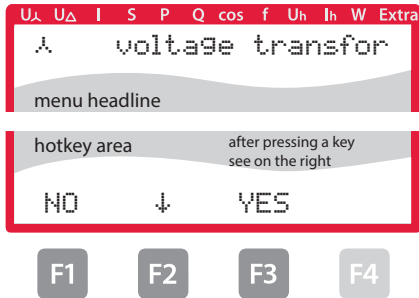

- F1** Leave setting menu without saving
- F2** Scroll through lines in the value range
- F3** Leave settings menu and save

## 6 Menu overview

In this chapter, you will find a complete overview of all menus and menu items of the multimes.

### 6.1 Main menu $U_{ph-n}$ voltage

Menu: U Phase - N

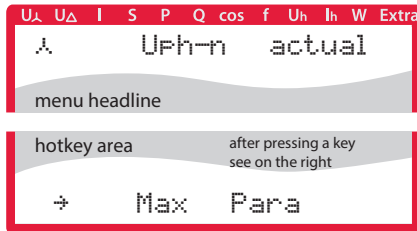

- F1** Scroll through main menu
- F2** Display and processing of minimum and maximum values
- F3** Entry for configuration => limits and voltage transformer

### 6.2 Main menu $U_{ph-ph}$ voltage

Menu: U Phase - Phase

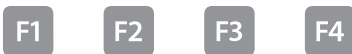
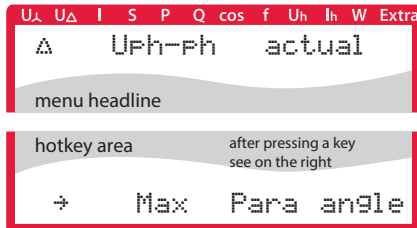

- F1** Scroll through main menu
- F2** Display and processing of minimum and maximum values
- F3** Configuration => limits and voltage transformer
- F4** Display of phase angle and measuring voltage asymmetry

### 6.3 Main menu I current

#### Menu: I Instataneous

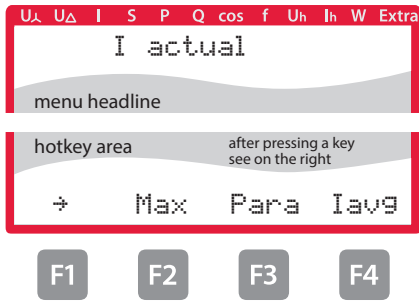

- F1** Scroll through main menu
- F2** Display and processing of minimum and maximum values
- F3** Configuration => limits and current transformer and voltage transformer
- F4** Continue to submenu current – average

#### 6.3.1 Submenu Im current average

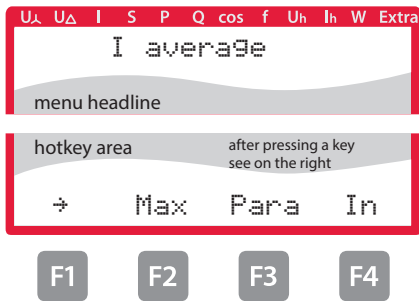

- F1** Scroll through main menu
- F2** Display and processing of minimum and maximum values
- F3** Configuration of limits and Im average value time
- F4** Continue to neutral conductor current menu

#### 6.3.2 Submenu In neutral conductor current

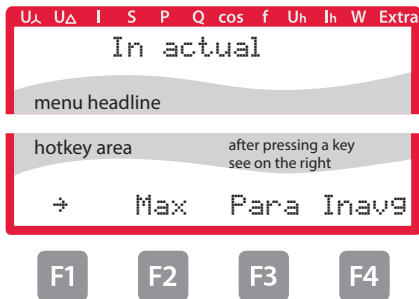

- F1** Scroll through main menu
- F2** Display and processing of minimum and maximum values
- F3** Configuration of limits and current transformer
- F4** Continue to submenu neutral conductor current – average

### 6.3.3 Submenu In average neutral conductor current

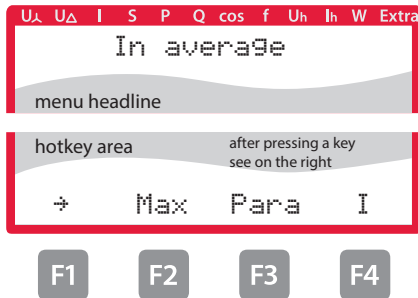

- F1 Scroll through main menu
- F2 Display and processing of minimum and maximum values
- F3 Configuration of limits
- F4 Return to main menu

### 6.4 Main menu S apparent power

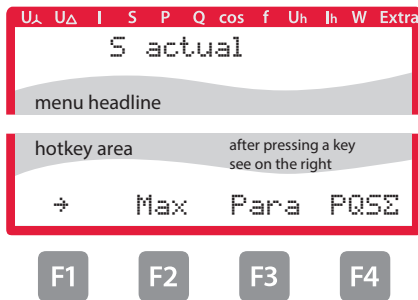

- F1 Scroll through main menu
- F2 Display and processing of minimum and maximum values
- F3 Entry for configuration => limits
- F4 Submenu totals for active, reactive and apparent power

#### 6.4.1 Submenu PQS display of totals for active, reactive and apparent power

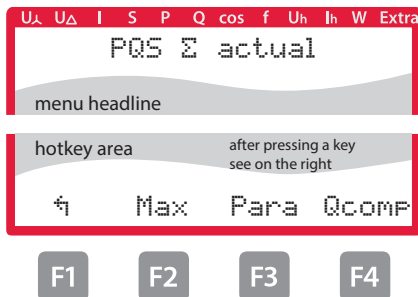

- F1 Return
- F2 Display and processing of minimum and maximum values
- F3 Configuration of limits

## 6.5 Main menu P active power:

Menu: P instantaneous value

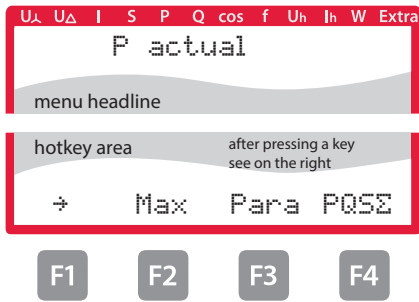

- F1 Scroll through main menu
- F2 Display and processing of minimum and maximum values
- F3 Configuration => limits
- F4 Submenu totals for apparent, active and reactive power

### 6.5.1 Submenu PQS display of totals for apparent, active and reactive power

For a description, see limit “Submenu PQS display of totals for apparent, active and reactive power”.

## 6.6 Main menu Q reactive power (fundamental)

Menu: Q1 instantaneous value

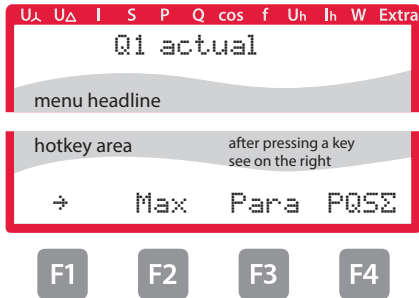

- F1 Scroll through main menu
- F2 Display and processing of minimum and maximum values
- F3 Entry for configuration => limits
- F4 Submenu totals for apparent, active and reactive power

### 6.6.1 Submenu PQS display of totals for apparent, active and reactive power

For a description, see limit “Submenu PQS display of totals for apparent, active and reactive power:”

## 6.7 Instantaneous value Cos Phi

### Menu cos $\varphi$ instantaneous value

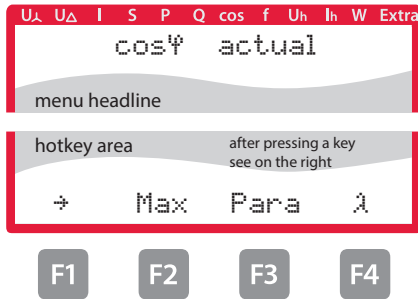

- F1** Scroll through main menu
- F2** Display and processing of minimum and maximum values
- F3** Entry for configuration => limits
- F4** Submenu power factor

#### 6.7.1 Submenu power factor

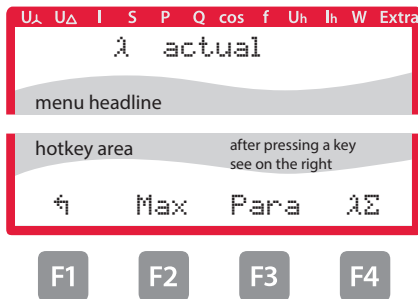

- F1** Return
- F2** Display and processing of minimum and maximum values
- F3** Configuration of limits
- F4** Submenu power factor, total

#### 6.7.2 Submenu totals of power factors

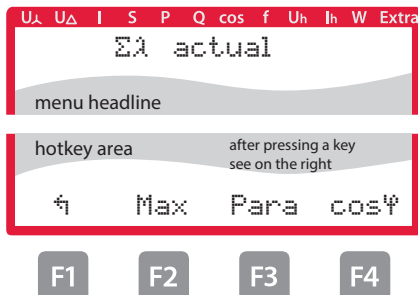

- F1** Return
- F2** Display and processing of minimum and maximum values
- F3** Configuration of limits
- F4** Return to main menu

## 6.8 Main menu F frequency

Menu: F instantaneous value

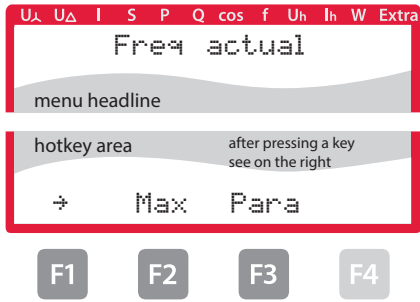

## 6.9 Main menu Uh voltage distortion factor

Menu: Uh instantaneous value as a graphic

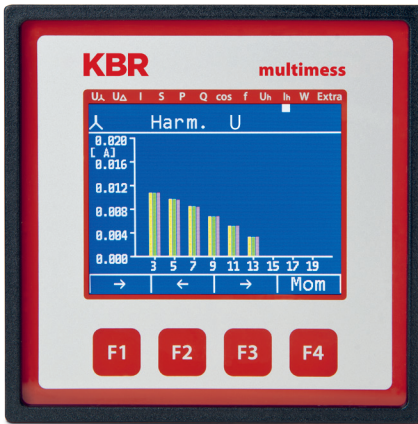

F1 Scroll through main menu

F4 Continue to values and individual harmonics

### 6.9.1 Submenu 3rd harm. U

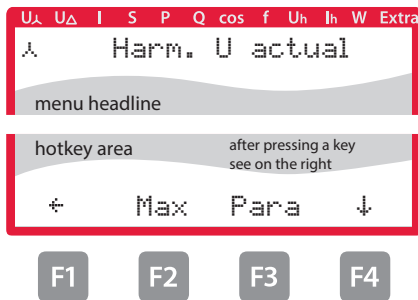

F1 Back to main menu

F2 Display and processing of maximum values

F3 Entry for configuration => limits

F4 Continue to next harmonic oscillation



#### NOTE

Display up to 19th harmonic same as for 3rd harmonic.  
13. harm. to 19th harm. without limits, 21th to 63th harm. only instantaneous values

## 6.10 Main menu I<sub>h</sub> distortion current strength

Menu: I<sub>h</sub> instantaneous value as a graphic

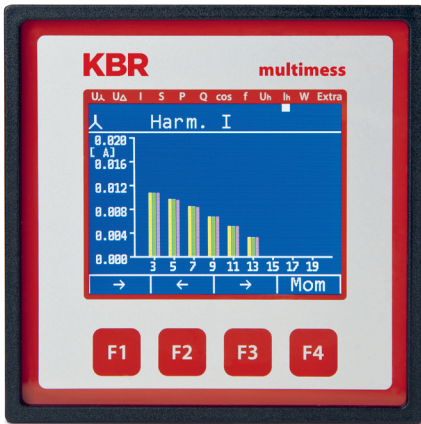

F1 Scroll through main menu

F4 Continue to values and individual harmonics

### 6.10.1 Submenu 3rd harm. I

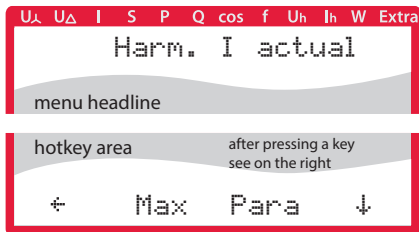

F1 Back to main menu

F2 Display and processing of maximum values

F3 Entry for configuration => limits

F4 Continue to next harmonic oscillation



#### NOTE

Display up to 19th harmonic same as for 3rd harmonic.  
13. harm. to 19th harm. without limits, 21th to 63th harm. only instantaneous values

## 6.11 Main menu W - active and reactive energy / consumption and recovery

### Menu: W active and reactive energy

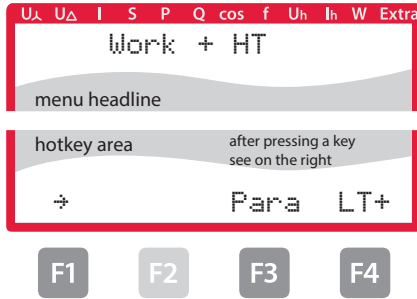

- F1** Scroll through main menu
- F3** Entry for configuration  
=> tariff and synchronization
- F4** Submenu active energy  
low tariff consumption

### 6.11.1 Submenu W active energy low tariff consumption

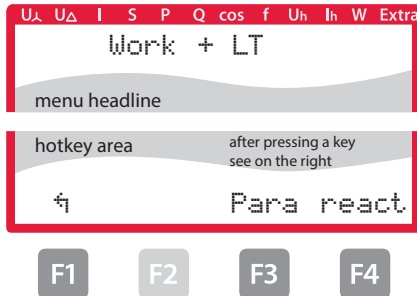

- F1** Return
- F3** Entry for configuration  
=> limits
- F4** Submenu reactive energy  
high tariff consumption

### 6.11.2 Submenu W reactive energy high tariff consumption

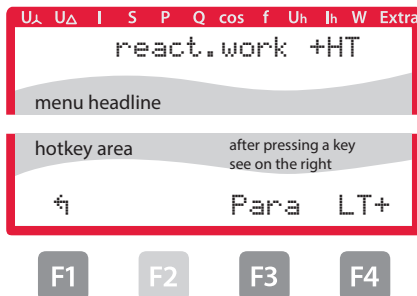

- F1** Return
- F3** Entry for configuration  
=> tariff and synchronization
- F4** Submenu reactive energy  
low tariff consumption

### 6.11.3 Submenu W reactive energy low tariff consumption

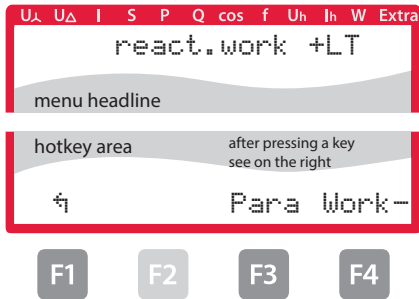

- F1 Return
- F3 Entry for configuration => tariff and synchronization
- F4 Submenu active energy high tariff recovery

### 6.11.4 Submenu W active energy high tariff recovery

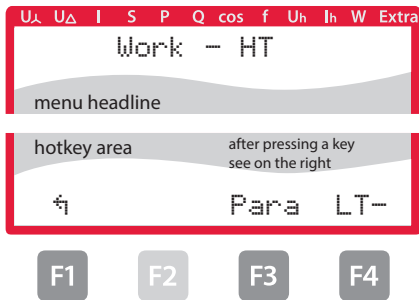

- F1 Return
- F3 Entry for configuration => tariff and synchronization
- F4 Submenu active energy low tariff recovery

### 6.11.5 Submenu W active energy low tariff recovery

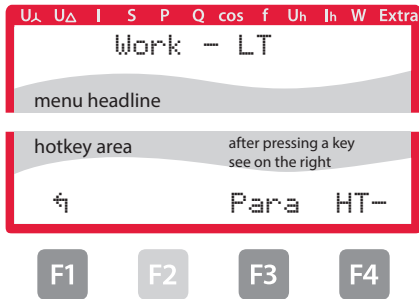

- F1 Return
- F3 Entry for configuration => tariff and synchronization
- F4 Submenu reactive energy high tariff recovery

### 6.11.6 Submenu W reactive energy high tariff recovery

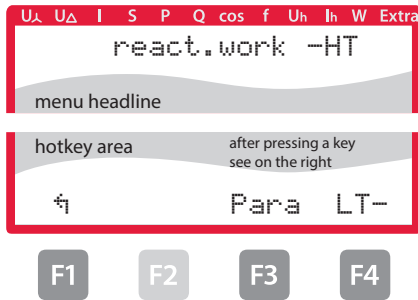

- F1** Return
- F3** Entry for configuration  
=> tariff and synchronization
- F4** Submenu reactive energy  
low tariff recovery

### 6.11.7 Submenu W reactive energy low tariff recovery

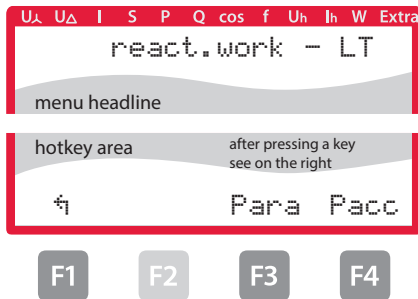

- F1** Return
- F3** Entry for configuration  
=> tariff and synchronization
- F4** Display of maximum  
active energy of the period consump-  
tion

## 6.12 Main menu Extra

### Firmware information

The diagram illustrates the 'Main menu Extra' screen for firmware information. At the top, a red bar contains the menu items:  $U_{\Delta}$ ,  $U_{\Delta}$ , I, S, P, Q, cos, f,  $U_h$ ,  $I_h$ , W, and Extra. The main display area shows 'Firmware info' in a monospaced font. Below this is a grey 'menu headline' area. A 'hotkey area' is shown below the headline, with a grey bar above it containing the text 'after pressing a key see on the right'. The hotkey area displays a right-pointing arrow followed by 'setup Info Diag'. Below the hotkey area are four function keys: F1, F2, F3, and F4. To the right of the screen, a legend lists the functions for each key: F1 (Scroll through main menu), F2 (Device configuration), F3 (Message), and F4 (Diagnosis for measuring voltage dip, available after voltage dip only).

F1 Scroll through main menu

F2 Device configuration

F3 Message

F4 Diagnosis for measuring voltage dip, available after voltage dip only

In versions option 6 and 7, the device can record measuring voltage dips. They can be displayed calling up the Diag (F4) menu item in the Extras window.

Configuration of this function is only possible with the visual energy computer software.

The measuring voltage dips recorded are not saved and are deleted in case of a power failure.

### 6.12.1 Setting transformer ratio

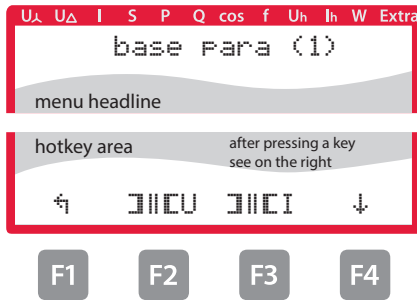

- F1 Return
- F2 Voltage transformer ratio configuration
- F3 Current transformer ratio configuration
- F4 Continue with basic para (2)

### 6.12.2 Time and bus communication

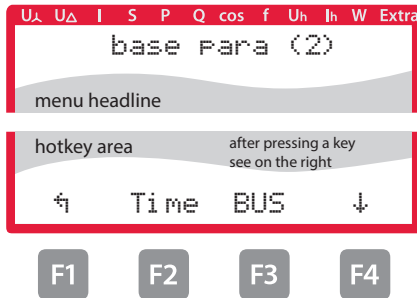

- F1 Return
- F2 Set time (time, date, daylight saving time)
- F3 Set bus parameters (baud rate, address, protocol etc.), see attachment
- F4 Continue with basic para (3)

### 6.12.3 Set display and attenuation coefficient

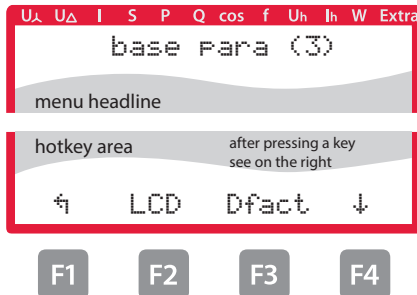

- F1 Return
- F2 Brightness, color adjustment, display test, dimmer
- F3 Set attenuation coefficient for current and voltage
- F4 Continue with basic para (4)

### 6.12.4 Set language and pulse output

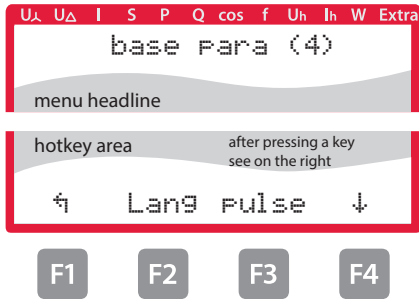

- F1 Return
- F2 Set user language (German / English)
- F3 Configure pulse output
- F4 Continue with basic para (5)

### 6.12.5 Configure relay outputs

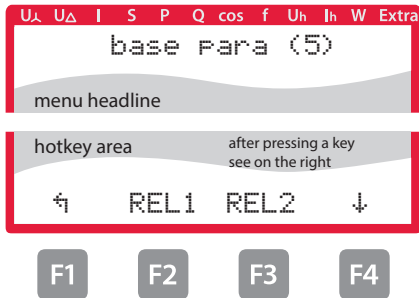

- F1 Return
- F2 Configure relay output 1
- F3 Configure relay output 1
- F4 Continue with basic para (6)

### 6.12.6 Password and reset

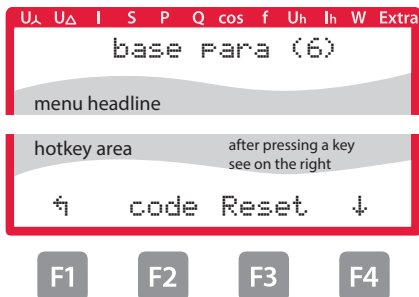

- F1 Return
- F2 Password entry / password protection
- F3 Reset limits, extreme values, meters or reset to default settings
- F4 Continue with basic para (7)

### 6.12.7 Zero-point creator

Configuration as described below:

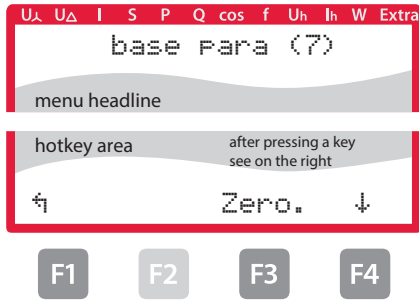

U<sub>Δ</sub> U<sub>Δ</sub> I S P Q cos f U<sub>h</sub> I<sub>h</sub> W Extra

base Para (7)

menu headline

hotkey area after pressing a key see on the right

← Zero. →

F1 F2 F3 F4

- F1 Return
- F2 Default menu Start (selection)
- F3 Activate/deactivate zero-point creator:
- F4 Continue with basic para (1)

After pressing the **F3** (EDIT) button, the following is displayed in the hot key area:

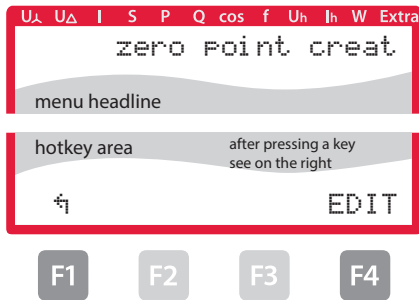

U<sub>Δ</sub> U<sub>Δ</sub> I S P Q cos f U<sub>h</sub> I<sub>h</sub> W Extra

zero Point creat

menu headline

hotkey area after pressing a key see on the right

← EDIT →

F1 F2 F3 F4

- F1 Return
- F4 Activation and selection zero-point creator on/off

After pressing the **F4** (EDIT) button, the following is displayed in the hot key area:

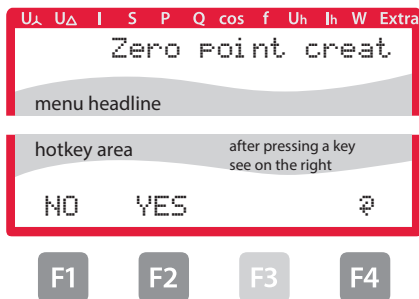

U<sub>Δ</sub> U<sub>Δ</sub> I S P Q cos f U<sub>h</sub> I<sub>h</sub> W Extra

Zero Point creat

menu headline

hotkey area after pressing a key see on the right

NO YES →

F1 F2 F3 F4

- F1 Discard changes
- F2 Confirm and save settings
- F4 Selection off / on

After confirming to save your settings by pressing **F2** and returning with the **F1** (**↶**) button, the following is displayed in the hot key area:

The screenshot shows a menu interface with a red border. At the top, a row of menu items is visible: U<sub>Δ</sub>, U<sub>Δ</sub>, I, S, P, Q, cos, f, U<sub>h</sub>, I<sub>h</sub>, W, Extra. Below this, the text 'base Para (7)' is displayed. A grey bar labeled 'menu headline' is positioned below the text. The bottom section is labeled 'hotkey area' and contains the text 'Zero.' with a left arrow key and a down arrow key. To the right of this section, the text 'after pressing a key see on the right' is visible. Below the hotkey area, four function keys are shown: F1, F2, F3, and F4. To the right of the screenshot, a legend lists the functions for each key: F1 Return, F2 Default menu Start (selection), F3 Activate/deactivate zero-point creator:, and F4 Continue with basic para (1).

### 6.13 Reset to default settings

Reset should only be carried out during setup and when the device is completely reprogrammed.



#### CAUTION

Reset will reset all programmed values to their default settings!!!

Reset is carried out in the menu **Extras - sub menu Reset / Default settings**.

The device is reset to its default settings, i.e. all stored data is lost!

This includes all operating parameters, limits and extreme values as well as the off-delay of the signaling relays.

The memory for limit violations is deleted.

The settings for time, date and bus address are not affected by a reset.



#### CAUTION

Check all operating parameters for correctness!

## 7 Modbus interface



### NOTE

Availability of data points depends on the device version.

### 7.1 Description Modbus interface for Modbus RTU or ASCII

The multimess F96 TFT-xxx-5 is optionally available with a Modbus RTU or ASCII interface. In order to use these, the device has to be converted from the KBR eBus to the Modbus RTU or ASCII bus protocol.

To do so, proceed as follows:

#### Main menu Extra

Firmware Info				Menu heading
<b>F1</b>	<b>F2</b>	<b>F3</b>	<b>F4</b>	
→	Setup	Info		Display hot-key area
				Messages about limit violations
				Device configuration menu
Scroll through main menu				

Press the **F2** and then the **F4** button.

#### 7.1.1 Change bus protocol

Basic para (2)				Menu heading
<b>F1</b>	<b>F2</b>	<b>F3</b>	<b>F4</b>	
←	Time	Bus	+	Display hot-key area
				Other basic para (3)
				Set bus parameters (baud rate, address, protocol etc.)
				Set time (time, date, daylight saving time)
Return				

After confirmation with the **F3** button, the following display appears:

Bus Parameters				Menu heading
<b>F1</b>	<b>F2</b>	<b>F3</b>	<b>F4</b>	
↶		eBus	EDIT	Display hot-key area
				Change bus protocol (Modbus, eBus)
				Set Ebus parameters (address)
Return				

Start the entry with the **F4** button and then change the bus protocol with **F3** by switching from KBR eBus to Modbus.

Basic Para (2)				Menu heading
<b>F1</b>	<b>F2</b>	<b>F3</b>	<b>F4</b>	
NO	YES		EDIT	Display hot-key area
				Selecting the Modbus bus protocol
				Save changes
Discard changes				

Subsequently, save the changes with **F2** or discard them with **F1**. The device reboots and accepts the new configuration.

Bus Parameters				Menu heading
<b>F1</b>	<b>F2</b>	<b>F3</b>	<b>F4</b>	
↶		ModB	EDIT	Display hot-key area
				Selecting the bus protocol (eBus or Modbus)
				Call up Modbus settings
Return				

Use the **F3** button to call up the Modbus settings.

ModBus settings				Menu heading
<b>F1</b>	<b>F2</b>	<b>F3</b>	<b>F4</b>	
↵			EDIT	Display hot-key area
				Configuring the Modbus bus protocol
Return				

By pressing **F4**, call up the settings menu for the Modbus address and bus protocol.

The following protocols can be set:

4.8k Baud, 9.6k Baud, 19.2k Baud with the respective parity even / odd or no Parity in Modbus RTU or ASCII.



#### NOTE

The default setting of the Modbus transmission in mode RTU and ASCII is 19.2 kBaud, even parity, 8 data bits, 1 stop bit.

## 7.2 Ethernet interface for Modbus TCP

The multimess F96 TFT-xxx-5 is optionally available with an interface for Modbus TCP.

### Main menu Extra

Firmware information				Menu heading
<b>F1</b>	<b>F2</b>	<b>F3</b>	<b>F4</b>	
→	Setup	Mes- sage		Display hot-key area
		Messages about limit violations		
	Device configuration menu			
Scroll through main menu				

Press the **F2** and then the **F4** button.

### 7.2.1 Change bus paramters

Basic Para (2)				Menu heading
<b>F1</b>	<b>F2</b>	<b>F3</b>	<b>F4</b>	
←	Time	Bus	→	Display hot-key area
		Other basic para (3)		
	Set bus parameters (IP address, netmask (host) )			
	Set time (time, date, daylight saving time)			
Return				

Press the key **F3** .

Bus parameters				Menu heading
<b>F1</b>	<b>F2</b>	<b>F3</b>	<b>F4</b>	
←		IPadr		Display hot-key area
	Display / entry IP address and netmask (host)			
Return				

### 7.3 Modbus TCP configuration (software configuration)

The parameterization is done with the IOTService Tool. Source of supply:

<http://www.hi-flying.com/download-center-1/applications-1/download-item-iotservice>

With Modbus-TCP, the parameters must be set as shown in the following figure. The network parameters (IP address, mask, gate way, DNS) must be adapted to the local conditions.

The screenshot shows the 'Setup Detail' window with the following configuration settings:

System	UART	SOCKET
Telnet: <input type="checkbox"/> Enable	UART No: <input type="text" value="UART1"/>	SOCKET Name: <input type="text" value="netp"/>
Telnet Port: <input type="text" value="23"/>	UART Protocol: <input type="text" value="Modbus"/>	Security: <input type="text" value="Disable"/>
Telnet Echo: <input type="checkbox"/> Enable	Frame Length: <input type="text" value="18"/>	Security Key: <input type="text" value=""/>
Embedded Web: <input type="checkbox"/> Enable	Frame Time: <input type="text" value="100"/>	Connect Mode: <input type="text" value="Always"/>
Web Port: <input type="text" value="80"/>	Tag Enable: <input type="text" value="Disable"/>	Stop Serial: <input type="text" value=""/>
NTP: <input type="checkbox"/> Disable	Tag Start: <input type="text" value="0"/>	HeartBeat: <input type="text" value="Disable"/>
NTP Server: <input type="text" value=""/>	Tag End: <input type="text" value="0"/>	HeartBeat Time: <input type="text" value=""/>
NTP Port: <input type="text" value="123"/>	SWFlow Control: <input type="text" value="Disable"/>	HeartBeat Serial: <input type="text" value="..."/>
NTP GMT: <input type="text" value="0"/>	Xon: <input type="text" value="11"/>	Register Mode: <input type="text" value="Disable"/>
WiFi Roaming	Xoff: <input type="text" value="13"/>	Register Code: <input type="text" value="..."/>
WiFi Roaming: <input type="text" value="Disable"/>	Cli GetIn: <input type="text" value="Serial-String"/>	Max Client NumMax C...: <input type="text" value="5"/>
Scan RSSI Threshold: <input type="text" value="50"/>	Serial-String: <input type="text" value="+++"/>	
Connect RSSI Threshold: <input type="text" value="70"/>	Cli Wait Time: <input type="text" value="15"/>	
	Gap Time: <input type="text" value="10"/>	

Buttons at the bottom: Edit Script, Confirm, Cancel



**NOTE**

The UART parameters must be adapted to the local bus parameters.

Local Port: 502

Several connections via TCP to a serial interface are possible.

The Replies will only be sent back to the person making the request

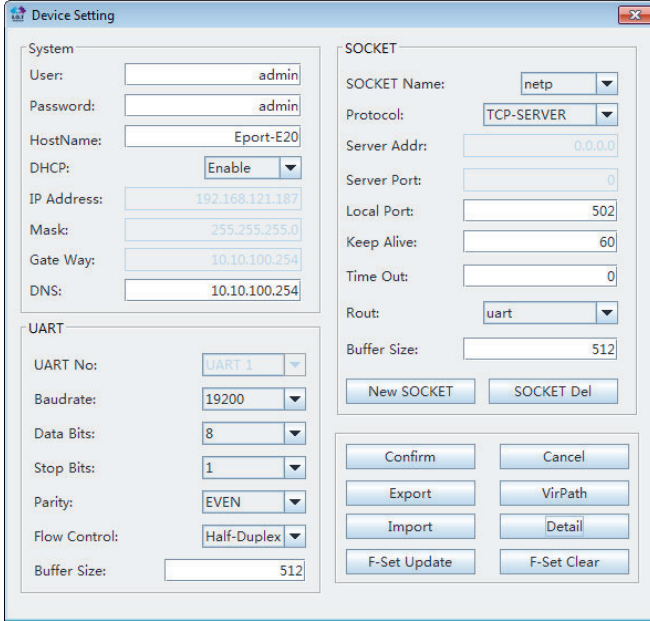

**NOTE**

**Modbus ASCII cannot be configured.**

Several connections via TCP to a serial interface are possible.

The replies are only sent back to the person making the request.

## 8 Ethernet interface for eBus TCP

The multimess F96 TFT-xxx-5 is optionally available with an interface for eBus TCP.

### Main menu Extra

Firmware Info				Menu heading
<b>F1</b>	<b>F2</b>	<b>F3</b>	<b>F4</b>	
→	Setup	Info		Display hot-key area
		Messages about limit violations		
	Device configuration menu			
Scroll through main menu				

Press the **F2** and then the **F4** button.

### 8.1. Change bus protocol

Basic para (2)				Menu heading
<b>F1</b>	<b>F2</b>	<b>F3</b>	<b>F4</b>	
←	Time	Bus	+	Display hot-key area
		Other basic para (3)		
	Set bus parameters			
	Set time (time, date, daylight saving time)			
Return				

After confirmation with the **F3** button, the following display appears:

Basic Para (2)				Menu heading
<b>F1</b>	<b>F2</b>	<b>F3</b>	<b>F4</b>	
←	Time	LAN	→	Display hot-key area
		Call up LAN settings		

Use the **F3** button to call up the LAN settings.

LAN settings				Menu heading
<b>F1</b>	<b>F2</b>	<b>F3</b>	<b>F4</b>	
←	SCAN	IPadr	EDIT	Display hot-key area
		Selecting the bus address		
		Display / entry IP address and netmask (host)		
	SCAN address is activated (for automatic eBus address assignment)			
Return				

By pressing **F3**, call up the settings menu for the IP address and netmask.

## 8.2 KBR eBus TCP configuration using the display

On the display, you can display and change the IP address in the menu item LAN and the subnet mask in the menu item Host.

On delivery, the devices are set to the IP address 192.168.0.1. This IP address is also shown in the display.

For this reason, it is recommended to check whether the device can be reached using this IP address.

When entering the netmask, observe the following chart:

Network Class	Host Bits	Netmask
A	24	255.0.0.0
B	16	255.255.0.0
C	8	255.255.255.0

The default setting is 8 bit (255.255.255.0)

## 8.3 KBR eBus TCP configuration (software configuration)

After installing and starting the IOT Service Tool, the connected network is scanned and the e-ports found are displayed, and can be further processed.

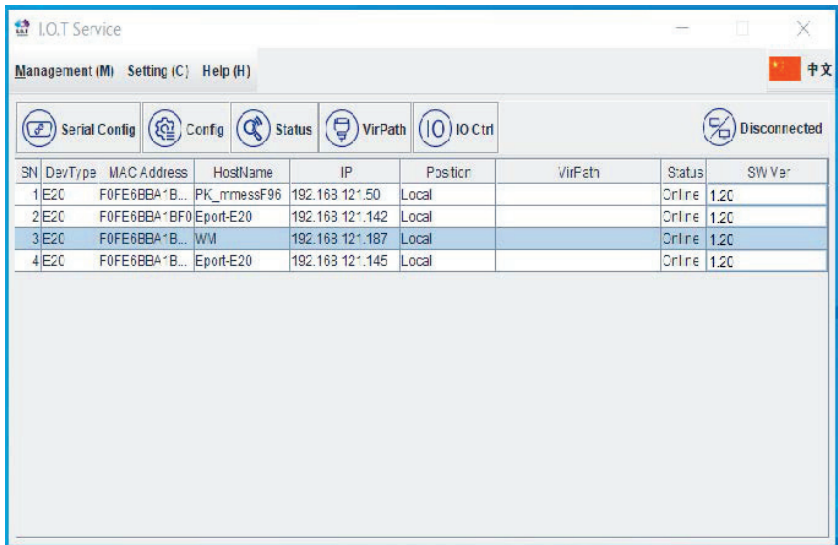

After selecting the e-port, click on "Config" to access the configuration settings.

**NOTE**

The default settings are configured on the KBR eBus. If Modbus is used, proceed as described in item 8.3.

### 8.3.1 Assigning an IP Address to a Device of which the Address is Not in the Address Range of the Network. I

In the main window of the IOT Service Tool, open the 'BroadCast Scan' window via **Setting (C) -> BroadCast**.

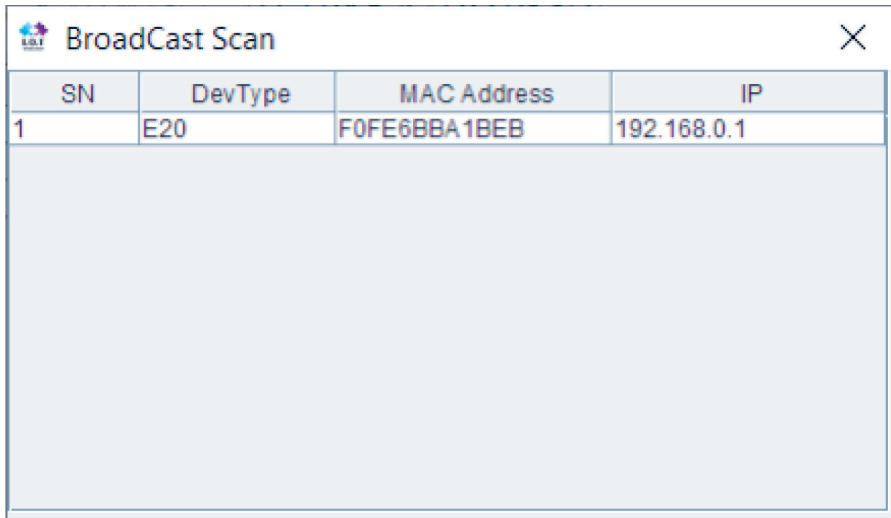

SN	DevType	MAC Address	IP
1	E20	F0FE6BBA1BEB	192.168.0.1

E-port devices that are in the network but do not have a valid network address are listed here.

Double-click on the row with the device in it to open the "Fast Setting" window:

**NOTE**

A valid IP address and the subnet mask can be entered here. Click "Confirm" to apply the settings.

The device should then appear in the list in the main 'IOT Service' window.

### 8.3.2 E-port Configuration for eBus TCP

For eBus TCP, the parameters must be set as shown in the figure below. The network parameters (IP address, mask, gateway, DNS) must be adapted to local circumstances.

The screenshot shows the 'Device Setting' window with the following configurations:

- System:**
  - User: admin
  - Password: admin
  - HostName: WM
  - DHCP: Disable
  - IP Address: 192.168.121.187
  - Mask: 255.255.254.0
  - Gate Way: 10.10.100.245
  - DNS: 10.10.100.254
- UART:**
  - UART No: UART 1
  - Baudrate: 38400
  - Data Bits: 8
  - Stop Bits: 1
  - Parity: EVEN
  - Flow Control: Half-Duplex
  - Buffer Size: 512
- SOCKET:**
  - SOCKET Name: netp
  - Protocol: TCP-SERVER
  - Server Addr: 192.168.121.187
  - Server Port: 8000
  - Local Port: 8000
  - Keep Alive: 60
  - Time Out: 0
  - Rout: uart
  - Buffer Size: 512

Buttons at the bottom include: New SOCKET, SOCKET Del, Confirm, Cancel, Export, VirPath, Import, Detail, F-Set Update, and F-Set Clear.



#### NOTE

“Flow Control: Half Duplex” controls the changeover of the RS485 component.

The web port must be set to 8000.

Click „Confirm“ to apply the parameters

## When “Detail” is selected, this window appears:

The screenshot shows the 'Setup Detail' window with the following configuration options:

- System:**
  - Telnet: **Enable**
  - Telnet Port: 23
  - Telnet Echo: **Enable**
  - Embedded Web: **Enable**
  - Web Port: 80
  - NTP: **Disable**
  - NTP Server: [Empty]
  - NTP Port: 123
  - NTP GMT: 0
- WiFi Roaming:**
  - WiFi Roaming: **Disable**
  - Scan R SSI Threshold: 50
  - Connect R SSI Threshold: 70
- UART:**
  - UART No: UART 1
  - UART Protocol: **NONE**
  - Frame Length: 18
  - Frame Time: 100
  - Tag Enable: **Disable**
  - Tag Start: 0
  - Tag End: 0
  - SW Flow Control: **Disable**
  - Xon: 11
  - Xoff: 13
  - Cli GetIn: **Serial-String**
  - Serial-String: +++
  - Cli Wait Time: 15
  - Gap Time: 10
- SOCKET:**
  - SOCKET Name: netp
  - Security: **Disable**
  - Security Key: [Empty]
  - Connect Mode: **Always**
  - Stop Serial: [Empty]
  - HeartBeat: **Disable**
  - HeartBeat Time: [Empty]
  - HeartBeat Serial: [Empty]
  - Regist Mode: **Disable**
  - Regist Code: [Empty]
  - Max Client NumMax C...: 5

Buttons at the bottom: Edit Script, Confirm, Cancel.



### NOTE

- For eBus TCP, the UART protocol must be set to “NONE”
- The gap time should be set to 10 (ms).  
(This is the waiting time after serial reception, until a telex message is sent via the network).
- Cli waiting time should be set to max. 15 (seconds).

## 9 Technical data in multimes F96 TFT-...-5

### 9.1 Measuring and display values

Wave form for U and I		any
Voltage	RMS value of a measurement interval	Phase - N: $U_{L1-N}; U_{L2-N}; U_{L3-N}$ / phase - phase: $U_{L1-2}; U_{L2-3}; U_{L3-1}$
	Units	[V, kV] display switches automatically
	Measuring range	0.00kV to 999.9 kV
Current (apparent current)	RMS value of a measuring interval	$I_{L1 Inst}; I_{L2 Inst}; I_{L3 Inst}$ ; instantaneous value for each phase
	Average value determination	$I_{L1 Av}; I_{L2 Av}; I_{L3 Av}$ ; floating average value from RMS values over a configurable period of time
	Units	[A;kA;MA]; display switches automatically
	Measuring range	0.00A to 999.9 kA
Neutral conductor	RMS value of a measuring interval	$I_{N Inst} / I_{N Avg}$ instantaneous and average value
	Units	[A;kA;MA]; display switches automatically
	Measuring range	0.00A to 1.2 MA
Frequency	Power frequency measurement	$f_{mains}$ ; measured with power supply correction
	Units	[Hz]
	Measuring range	45 ... 65 Hz
Apparent power	Calculation	$S_{L1}, S_{L2}, S_{L3}, S_{tot}$
	Units	[VA; kVA; MVA] display switches automatically
	Measuring range	0.00VA to 999MVA
Active power	Calculation	$P_{L1}, P_{L2}, P_{L3}, P_{total}$
	Units	[W; kW; MW] display switches automatically
	Measuring range	0.00W to 999MW

Reactive power	Calculation -> ind. and cap.	$Q_{L1}, Q_{L2}, Q_{L3}, Q_{total}$ ; distinction between ind./cap.
	Units	[Var; kvar; Mvar]; display is switched automatically.
	Measuring range	0.00VAr to 999Mvar
Power factor	Calculation -> ind. and cap.	$\cos\varphi_{L1}; \cos\varphi_{L2}; \cos\varphi_{L3}; LF_{L1}; LF_{L2}; LF_{L3}; LF_{tot.}$ ; distinction between ind./cap. $\cos\varphi$ in the display
	Measuring range	CosPhi 0.1ind. $\leftarrow$ 1 $\rightarrow$ 0.1cap., LF 0.1 - 1
Active energy	Calculation	W (HT/LT); $P_{average}$ max. of a measurement period
	Units	[Wh; kWh; MWh]; display is switched automatically
	Measuring range	0.0kWh to 9999999999.9kWh
Reactive energy	Calculation	$Wq$ (HT/LT) ind. or cap. ; $Q_{average}$ max. of a measuring period
	Units	[varh; kvarh; Mvarh]; display switches automatically
	Measuring range	0.0kvarh to 9999999999.9kvarh
Harmonics	Distortion factor (THD) for voltage	Voltage: $DF-U_{L1}; DF-U_{L2}; DF-U_{L3}$ ;
	Partial distortion factors	3 <sup>rd</sup> ; 5 <sup>th</sup> ; 7 <sup>th</sup> ; 9 <sup>th</sup> ; 11 <sup>th</sup> ; 13 <sup>th</sup> ; 15 <sup>th</sup> ; 17 <sup>th</sup> to 63 <sup>rd</sup> Harmonics of the voltage
	Units	[%]
	Measuring range	0.00% to 100%
harm. Harmonics of the current	Current harmonics	3 <sup>rd</sup> ; 5 <sup>th</sup> ; 7 <sup>th</sup> ; 9 <sup>th</sup> ; 11 <sup>th</sup> ; 13 <sup>th</sup> ; 15 <sup>th</sup> ; 17 <sup>th</sup> to 63 <sup>rd</sup> harmonic for each phase
	Total of current harmonics	Current: $Id_{L1}; Id_{L2}; Id_{L3}$ ; for each phase separately
	Units	[A]
	Measuring range	0.00A to 999.9kA

## 9.2 Measurement accuracy class (in accordance with DIN EN 61557-12)

Measured value	Symbol	Accuracy class
Voltage	$U_{PHN}$	0.5 / $\pm 1$ digit
Voltage	$U_{PHPH}$	0.5 / $\pm 1$ digit
Phase current 3 x 0,333mA AC (Messbereich 1)	I	0,5 / $\pm 1$ Digit
Phase current 3 x 0,066mA AC (Messbereich 2)	I	0,5 / $\pm 1$ Digit
Neutral conductor current calculated	$I_{Nc}$	2 / $\pm 1$ Digit
Power factor	$PF_A$	1 / $\pm 1$ Digit
CosPhi of the fundamental components		1 / $\pm 1$ Digit
Frequency	f	1 / $\pm 1$ Digit
Total apparent power	$S_A$	1 / $\pm 1$ Digit
Total active power	P	1 / $\pm 1$ Digit
Total reactive power	$E_a$	1 / $\pm 1$ Digit
Total reactive power fundamental components	$Q_a$	1 / $\pm 1$ Digit
Total reactive energy consumption and recovery	$Q_a$	1 / $\pm 1$ Digit
Voltage harmonics	$U_h$	1 / $\pm 1$ Digit
THD of the voltage	THD- $R_u$	1 / $\pm 1$ Digit
Current harmonics	$I_h$	1 / $\pm 1$ Digit

## 9.3 Measuring principle

Sampling	205 measuring points per period (50 Hz) 170 measuring points per period (60 Hz)
A/D converter	16 bit
Measurement of U and I	simultaneous recording of measured values for U and I;
Update speed	Display ~ 500 ms
Harmonics calculation	FFT with 2048 points over 10 periods (50 Hz) FFT with 2048 points over 12 periods (60 Hz)
Frequency measurement	Consumption: Voltage measured between phase L1, L2, L3 - N;

### 9.4 Device memory

Work, data & parameter memory		2 MB flash
Program memory		512 kB flash
Memory type		Ring buffer
Long-term memory (1 year)		Daily values for active and reactive energy (HT and LT) for consumption and recovery
Period memory for 1464 / 732 / 366 / 24 days		60 / 30 / 15 / 1 minute - values of: Active energy, reactive energy (each consumption and recovery)
Extreme values (max./min.)		Extreme values that occurred after connection to the power supply or after the extreme value memory has been deleted manually including date and time
Event memory	Memory size	1500 events including date and time of their occurrence
Operation logbook	Memory size	500 events including date and time of their occurrence
Limit violations:	Recording time	≥ 200 ms
Measuring voltage dips:	Recording time	≥ 20 ms; threshold can be set using the computer, value after reset 85% of rated voltage (according to EN 61000-4-30).

### 9.5 Power supply

Power supply	US1: 100 to 240V +/- 10% AC/DC 50/60 Hz; 8VA, 4W US5: 22.5 to 64V +/- 10% AC/DC 50/60 Hz; 8VA, 4W
--------------	--



#### NOTE

To protect your purchased high-quality devices from damage, we strongly recommend that you take overvoltage protection measures. Protect control voltage inputs, pulse and bus lines.

Systems that are at risk from lightning strikes must feature lightning protection for all input and output lines.

## 9.6 Hardware inputs and outputs

### 9.6.1 Hardware inputs

Voltage measurement inputs	UL1-L2; UL2-L3; UL3-L1	3 x 5V...100V...120V AC (measuring range 1) 3 x 20V... 500V...600V AC (measuring range 2)
	Input impedance	1.2 MOhm (Ph-Ph)
	Measuring range	Can be configured using voltage transformers
Current measuring input		3 x 333 mV AC (measuring range 1) 3 x 66 mV AC (measuring range 2)
	Power consumption	≤ 0.3VA per input at 6A
	Measuring range	Can be configured using current transformers

### 9.6.2 Hardware outputs

Signaling relay for limit violations (optional)	Number	2
	Contact	floating
	Reaction speed	programmable, 0 to 254 seconds
	Switching capacity	250V AC / 2A;
Pulse output	Output type	Active and reactive energy 0.001 to 9990 pulses per KWH or kvar
	Optocoupler output	15 mA at max. 35 V; S <sub>0</sub> -compatible
	Accuracy class	2
	Pulse length	Programmable, 30 to 990 ms
	Power supply	external
Interface (option)	<b>BUS</b>	RS485 for connection to the KBR eBus or Modbus; max. 32 devices, up to 1000 devices with bus repeater
	Baud rate	38400 fixed at KBR eBus, configurable with Modbus
	Address assignment	Can be addressed automatically with software or manually on the device up to address 9999. For Modbus: 1 to 247 manually on the device.
	<b>LAN</b>	IEEE 802.3
	speed	10 Mbit / 100 Mbit
	Connection	IEEE 802.3 10base-t / 10base-TX, cable CAT5

### 9.7 Electrical connection

Connection elements		Screw terminals
Permissible cross-section of the connecting cables		2.5 mm <sup>2</sup>
Measurement voltage inputs	Fuse	max. 1 A slow-blow max. C2 automatic isolating switch UL/IEC-approved
Measuring current inputs	Fuse	NONE!!! Always short-circuit current transformer terminals k and l before opening the circuit!
Input control voltage	Fuse	max. 1 A slow-blow max. C2 automatic isolating switch UL/IEC-approved
Relay output	Fuse	max 2A medium time-lag
BUS connection	Connection material	For proper operation, please only use shielded twisted-pair cables; e.g. I-Y-St-Y 2x2x0.8
Pulse output	Connection and cables	Observe correct polarity! For proper operation, please only use shielded twisted-pair cables; e.g. I-Y-St-Y 2x2x0.8
Transformer connection	Connections	See connection diagram
Interfaces Connection	RS485 BUS connector pins	Terminal 90 (L) Terminal 91 (A) Terminal 92 (B)

### 9.8 Mechanical data

Switch-board installation	Housing dimensions	96 x 96 x 65 mm (H x W x D)
	Installation cut-out	92 x 92 mm
	Weight	min. 300g, max. 350g, depending on optional board

## 9.9 Standards and miscellaneous

Ambient conditions	Standards	DIN EN 60721-3-3:1995-09 + DIN EN 60721-3-3/A2:1997-07; 3K5+3Z11; (IEC721-3-3;3K5+3Z11)	
	Operating temperature	K55 (-5°C .... +55 °C)	
	Air humidity	5% .... 95% non-condensing	
	Storage temperature	K55 (-25°C .... +70°C)	
	Operating height	0...2,000 m above sea level	
Electrical safety	Standards	DIN EN 61010-1:2011-07; DIN EN 61010-2-030:2011-07	
	Protection class	I	
	Oversvoltage category, measurement category	Voltage measurement: Current measurement: Power supply:	CAT III: 300 V; CAT II: 400 V CAT III: 300V CAT III: 300V
	Rated surge voltage	4kV	
Protection type	Standards	DIN EN 60529:2014-09	
	Front	IP 40, with IP 51 seal	
	Terminals	IP 20	
EMC	Standards	DIN EN 61000-6-2:2006-03 + amendment 1:2011-03 DIN EN 611326-1:2013-07  Devices without Profibus DP DIN EN 61000-6-3:2011-09 + amendment 1:2012-11  Devices with Profibus DP DIN EN 61000-6-4:2011-09	
Synchronization	Type	internal, tariff switching or by KBR eBus	
Synchronization time		With internal synchronization based on the full hour	

## 9.10 Default settings after a reset (delivery state)

Primary voltage/secondary voltage	400 V/400 V
Primary current/secondary current	1000 A/333 mV
Zero-point creator	off
Measurement period time	15 minutes
Current average time	10 minutes
Daylight saving time	from month 03 to 10
Frequency correction	automatic
Tariff switching	via KBR eBus
Low tariff time	programmed time for internal switching of HT and LT: 22:00 - 6:00 (10pm to 6am)
Language	Germ. (German text display)
Attenuation coefficient for current and voltage	DF 0 (no attenuation)
Energy pulse	P (active power for consumption), 1 (1,000) pulse /kWh, pulse length 100 ms
Alarm relay	On delay tON = 0 sec Off delay tOFF = 0 sec
Measurement period synchronization	Internal
Password	9999/all functions can be accessed
Button buzzer (volume)	activated, 50%
Limit hysteresis	01 %
Default menu Start selection	Deactivated

### Unaffected by a RESET:

1. Bus communication
2. Time
3. Language







**KBR GmbH**

Am Kieferschlag 7  
D-91126 Schwabach

T +49 (0) 9122 6373 -0  
F +49 (0) 9122 6373 -83  
E [info@kbr.de](mailto:info@kbr.de)

[www.kbr.de](http://www.kbr.de)