

## Operating instructions

# Power Quality network analyzer multimes F144-PQ

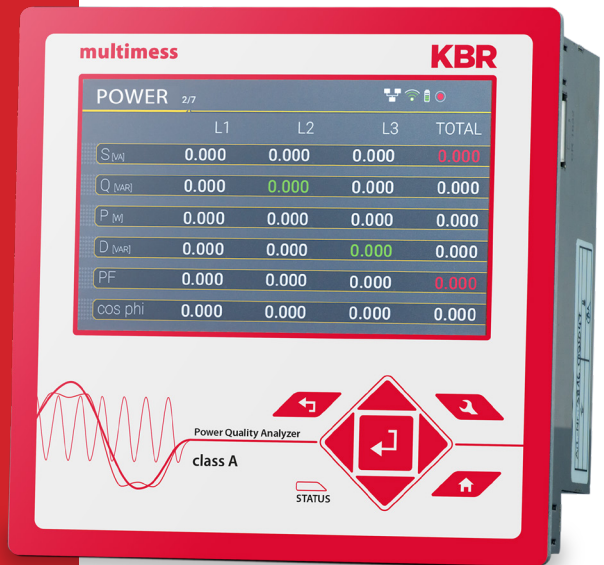

KBR GmbH does not accept any liability for damage or losses of any kind arising from printing errors or changes in this manual.

Furthermore, KBR GmbH will not accept any liability for loss or damage of any kind resulting from faulty equipment or devices that have been modified by the user.

Copyright 2024 KBR GmbH

Subject to change without prior notice.

1.	User prompt .....	6
1.1	Target group.....	6
1.2	Warnings.....	6
1.3	Notes .....	7
1.4	Other symbols .....	7
1.5	Applicable documentation .....	7
1.6	Keeping .....	7
2	Scope of Delivery/Order Codes .....	8
3	Safety instructions.....	10
3.1	Meaning of the symbols used on the device .....	10
3.2	Site information and assembly instructions of multimess F144-PQ.....	11
4	Intended use .....	11
5.	Technical Data.....	12
5.1	multimess F144-PQ Description .....	12
5.2	Technical Data.....	14
5.2.1	Dimensions / Weight .....	15
5.2.2	Power supply.....	15
5.2.3	Electrical safety – environ-mental parametert.....	16
5.2.4	Spannungs-Messeingänge .....	17
5.2.5	Current inputs.....	19
5.2.6	Residual current monitor (RCM).....	20
5.2.7	Binary inputs / binary out-puts .....	20
5.2.8	Temperature input .....	21
5.2.9	Protective earth.....	21
5.2.10	Storage of measured values .....	22
5.2.11	Communication Protocols.....	22
5.2.12	Time synchronization interface.....	22
5.2.13	Communication Interfaces.....	22
5.3	Mechanical design .....	24
5.3.1	Battery .....	25
5.4	Terminal strip number multimess F144-PQ .....	26
5.4.1	Assembly instructions.....	29
5.5	Supply Voltage Connectionss .....	30
5.6	Mains connection for multimess F144-PQ .....	32
5.6.1	3-phase / 4-wire connection.....	32
5.6.2	4-wire connection without neutral current .....	34
5.6.3	4-wire / 1-phase .....	36
5.6.4	3-phase / 3-wire connection.....	37
5.6.4.1	Connection to secondary transformer.....	37

5.7	Additional interfaces .....	39
5.7.1	RS232 / RS485 Interfaces .....	39
5.7.1.1	Connection and Termination RS232/RS485 Interface .....	39
5.7.1.2	Connection of PQI-DE as Modbus Master in a bus .....	41
5.7.2	Temperature input PT100/PT1000 .....	42
5.7.3	Differential current input .....	43
5.7.4	Output relays.....	44
5.7.5	Binary Inputs .....	45
5.8	Measurement / Functions .....	46
5.8.1	Continuous Recording:.....	46
5.8.2	PQ-Events .....	47
5.8.3	Recorder triggering .....	47
5.8.4	Memory management.....	48
5.8.4.1	Memory Expansion with SD Card .....	49
6.	Operation of the multimess F144-PQ.....	50
6.1	Getting started .....	50
6.2	Initial Setup - Operation of the Assistant.....	50
6.3	First commissioning - wizard - procedure .....	51
6.3.1	Wizard setting: Language.....	51
6.3.2	Wizard setting: Power Quality standard .....	51
6.3.3	Wizard setting: Net type.....	52
6.3.4	Wizard setting: Net frequency .....	52
6.3.5	Wizard setting: Voltage Transformer.....	53
6.3.6	Wizard setting: Voltage Grid .....	53
6.3.7	Wizard setting: Current Transformer.....	54
6.3.8	Wizard setting: Transformer Factor Equipment.....	54
6.3.10	Wizard setting: Date, Time and Timezone .....	55
6.3.11	<b>Setup-wizzard: Communication settings.....</b>	<b>56</b>
6.3.12	Wizard setting: Security Mode.....	58
6.3.13	Wizard End of commissioning .....	59
6.4	Display .....	60
6.4.1	Numerical display .....	60
6.4.3	Pop-up display for residual current measurement messages.....	68
6.4.3.1	Pop-up Display Alarm Message.....	68
6.4.3.2	Pop-up Display Warning Message.....	69
6.4.3.3	Pop-up Display Error Message.....	70
6.5	Setup display.....	71
6.5.1	Parameter .....	71
6.5.2	Residual Current Measurement / RCM.....	74

6.5.3	Time settings.....	76
6.5.3.1	Time settings DCF77.....	76
6.5.3.2	Connection DCF77 radio clock.....	77
6.5.3.3	Manual time setting .....	78
6.5.3.5	NTP time setting .....	80
6.5.3.6	NMEA-ZDA time setting.....	81
6.5.3.7	NMEA-RMC time setting .....	81
6.5.3.8	IRIG-B time setting .....	82
6.5.3.9	IEEE 1344 time setting .....	83
6.5.4	Basic setting.....	84
6.5.5	Password lock device display.....	85
6.5.6	Memory management.....	86
6.5.7	Setting up the device interfaces .....	86
6.5.8	Display .....	87
6.6	Display lock.....	88
7	Modbus .....	89
7.1	Modbus Datenpunktliste .....	89
7.1.1	Modbus settings .....	90
7.1.2	Modbus RTU.....	90
7.1.3	Modbus TCP.....	90
7.1.4	Set-up parameter Modbus with WinPQ .....	91
7.1.5	Byte Order .....	92
7.1.6	Modbus-Register-Order .....	92
7.1.7	Data bits .....	93
7.1.8	Data types .....	93
8.	Webserver .....	96
8.1	Parameterisation.....	96
8.2	Access and REST-API.....	96
9.	Measurement data – Measurement methods multimes F144-PQ.....	97
10.	Service .....	105
11.	Disposal.....	105
12.	Product Warranty.....	105

# 1. User prompt

The user manual contains all important information for installation, commissioning and operation. Read the instruction manual completely and do not use the product until you have understood the instruction manual.

## 1.1 Target group

These operating instructions are intended for trained and qualified staff as well as trained and tested operators. The contents of these operating instructions must be made accessible to the persons responsible for installing and operating the system.

## 1.2 Warnings

 <b>SIGNAL WORD</b>	<b>Type and source of danger!</b> ➔ Consequences of non-observance ➔ Action to avoid the danger.
---	--

### 1 Types of warnings

Warnings differ according to the type of danger as follows:

 <b>DANGER!</b>	Warns of an imminent danger which, if not avoided, will result in death or serious injury.
---	--

 <b>WARNING!</b>	Warns of a potentially dangerous situation that can result in death or serious injuries when not avoided.
--	---

 <b>CAUTION!</b>	Warns of a potentially dangerous situation that can result in fairly serious or minor injuries when not avoided.
--	--

<b>NOTICE!</b>	Warns of a potentially dangerous situation that if not avoided could result in material or environmental damage.
----------------	--

	Refers to procedures that do not present a risk of injury or damage to property, but which must be observed to ensure reliable operation of the appliance!
---	--

### 1.3 Notes

Notes on appropriate use of the device.

### 1.4 Other symbols

#### 1 Instructions

Structure of the instructions:

Guidance for an action..

➔ Indication of an outcome, if necessary.

Lists

Structure of unnumbered lists:

0 ➔ List level 1

➔ List level 2

Structure of numbered lists:

1) List level 1

2) List level 1

1. List level 2

2. List level 2

### 1.5 Applicable documentation

For the safe and correct use of the product, observe the additional documentation that is delivered with the system as well as the relevant standards and laws.

### 1.6 Keeping

Keep the user manual, including the supplied documentation, readily accessible near the system.

## 2 Scope of Delivery/Order Codes

### 2.1 Scope of Delivery

- 0 ⇒ multimes F144-PQ
- 0 ⇒ User Manual
- 0 ⇒ Ethernet cable

### 2.2 Order Codes

Characteristic	Code
<b>Power Quality Interface and fault recorder</b> 0 ⇒ 4 voltage converters, 4 current transformers 0 ⇒ In accordance with DIN EN 50160 and IEC 61000-4-30 (Class A) 0 ⇒ 8 digital inputs 0 ⇒ 4 relay outputs 0 ⇒ WinPQ Lite software	multimes F144-PQ
Supply voltage (operation range) 0 ⇒ AC 90 V..110 V..264 V or DC 100 V..220 V..350 V 0 ⇒ DC 18 V..60 V..70 V	H1 H2
Supply voltage (operation range) 0 ⇒ 100V / 400V / 690V 10MΩ (CAT IV 300V)	
Current inputse 0 ⇒ 4 current inputs for metering circuit 1 A / 5 A (range 10 A)	
Binary inputs 0 ⇒ 8 programmable binary inputs (AC/DC 48..250 V)	
Option IEC 61000-4-7 (40.96 kHz sampling) 0 ⇒ Frequency measurement of voltage and current from 2 kHz to 20 kHz accord-ing IEC61000-4-7; 40.96 kHz sampling oscilloscope recorder	Option
Option communication protocol 0 ⇒ Modbus RTU & TCP	PO
Option RCM 0 ⇒ Residual current monitor RCM (5th current input)	Option
Operating instructions 0 ⇒ English	









With a licence code it is possible to upgrade the 2kHz to 20kHz option (40.96Hz sampling rate for oscilloscope images), as well as the RCM function.

<b>Software WinPQ lite</b>  For parameterising the multimes F144-PQ and for reading out the multimes F144-PQ measurement data and online data as a single user licence - free of charge on our homepage in the download area under Apps-Software-GSD files. <a href="https://www.kbr.de/en/download/apps-software-gsd-dateien/">https://www.kbr.de/en/download/apps-software-gsd-dateien/</a>	<b>Code</b>
<b>WinPQ-database</b>	<b>Kennung</b>
<b>Software WinPQ</b> For parameterization, archiving and evaluation of multimes D9-PQ and multimes F144-PQ measurement data with the following basic functions: <ul style="list-style-type: none"> <li>⇒ 432-bit/64-bit Windows program interface</li> <li>⇒ Database for saving the measured values per measuring point</li> <li>⇒ Data access via TCP/IP network</li> <li>⇒ Visualization option for all measured variables retrievable from a multimes D9-PQ and multimes F144-PQ as a function of time and as a statistical variable</li> <li>⇒ Automatic reporting according to EN50160; IEC61000-2-2 / 2-4; IEEE519; etc.</li> <li>⇒ Automatic export functions (Comtrade , PQDiff, ASCII, PDF) and fault report transmission</li> <li>⇒ One additional workstation license for one Windows user is included in the price</li> </ul>	WinPQ
<b>Lizenzen</b> <ul style="list-style-type: none"> <li>⇒ as single-user license for 2 PQ measuring instruments (multimes D9-PQ, multimes F144-PQ)</li> <li>⇒ as single-user license for 2 to 10 PQ measuring instruments (multimes D9-PQ, multimes F144-PQ)</li> <li>⇒ as single-user license for &gt; 10 PQ measuring instruments (multimes D9-PQ, multimes F144-PQ)</li> <li>⇒ as single-user license for &gt; 100 PQ measuring instruments (multimes D9-PQ, multimes F144-PQ)</li> </ul>	
<b>Operating instructions</b>	English
<b>Accessories – multimes F144-PQ</b>	<b>Code</b>
SD-memory card (external): 4 GB industrial standard	
Radio time clock interface DFC 77	
<b>GPS-Clock – Navilog Set - RS485</b> GPS receiver, GPS converter 5m connection cable, mounting bracket <b>Power supply for Navilog</b> (DIN rail power supply, 88-264VAC/24V, 10W)	

### 3 Safety instructions

- Follow the operating instructions.
- Keep the operating instructions with the device.
- Ensure that the device is operated only in a perfect condition.
- Never open the device.
- Ensure that only qualified personnel operate the device.
- Connect the device only as specified.
- Ensure that the device is operated only in the original condition.
- Connect the device only with recommended accessories.
- Ensure that the device is not operated outside the design limits. (Refer to the technical data in chapter 5.2)
- Ensure that the original accessories are not operated outside the design limits.
- Do not use the device in environments where explosive gases, dust or fumes occur.

#### 3.1 Meaning of the symbols used on the device

	<p><b>Nature and source of the danger!</b> Read the safety instructions inside the manual!</p>
	<p>Protection earth of the measuring device</p>
	<p>USB-interface</p>
	<p>TCP-IP interface</p>
	<p>CE marking guarantees compliance with the European directives and regulations regarding Electromagnetic Compatibility (EMC)</p>
	<p>Alternating voltage (AC)</p>
	<p>Direct voltage (DC)</p>

### **3.2 Site information and assembly instructions of multimes F144-PQ**

The multimes F144-PQ is suitable for the following sites:

0 ⇒ Panel mounting

## **4 Intended use**

The product is used for the measurement and evaluation of voltage and current signals in the power grid only. If the instrument is used in a manner not specified by the manufacturer, the protection provided by the instrument may be severely impaired.

The instrument is intended for use in the low voltage range in CAT IV (300 V) up to a maximum of 690 V (conductor - conductor). Other voltage levels such as medium or high voltages must be connected to the instrument via voltage transformers.

## 5. Technical Data

### 5.1 multimes F144-PQ Description

The Power Quality Analyser and Fault Recorder multimes F144-PQ for low, medium and high voltage networks is the central component of a system with which all measurement tasks in electrical networks can be solved.

The multimes F144-PQ can be used as a Power Quality Interface according to power quality standards such as IEC61000-2-2 / EN50160 or to check the technical connection guidelines such as DIN VDE AR 4110 and DIN VDE 4120 and many more. Due to the available open SCADA standard interfaces Modbus RTU/TCP, the device can also be used as a highly accurate measurement transducer for all physically defined measured variables in 3-phase systems parallel to the continuous recording of measured values over a very long period.

In addition to the possibility of standard evaluations, the multimes F144-PQ also has a highspeed disturbance recorder with a recording rate of 40.96kHz/10.24kHz and a 10ms TRMS effective value recorder. This allows a detailed evaluation of grid disturbances.

The multimes F144-PQ is equipped with a fifth current input for continuous residual current monitoring (RCM). It is possible to freely program thresholds for alarms or warnings (from firmware version 2.2).

Modern Power Quality Analysers comply with the IEC 62586 standard, which describes the complete product feature of a Power Quality Analyser. This standard defines not only the purpose of use, the EMC environment and the environmental conditions, but also the exact measurement methods IEC 61000-4-30 - Class A, in order to create a comparable and reliable basis for the end-user.

According to IEC 62586, the multimes F144-PQ is a device of class PQI-A-FI-H and is therefore fully certified in external laboratories. Power Quality Interface – Class A – Fixed Installed Measurement Device for Indoor operation in Harsh EMC environments.

Parameter IEC61000-4-30	Class
Power frequency	A
Magnitude of the Supply Voltage	A
Flicker	A
Supply voltage dips and swells	A
Voltage interruptions	A
Supply voltage unbalance	A
Voltage harmonics	A
Voltage Interharmonic	A
Mains signalling voltage	A
Underdeviation and overdeviation	A
Measurement aggregation intervals	A
Time-clock uncertainty	A
Flagging	A
Transient influence quantities	A

The multimes F144-PQ meets the requirements of IEC 61000-4-30 Ed.3 (2015) for Class A measuring instruments for 100% of the parameters.

The measuring device and the development are subject to strict security requirements within the scope of the requirements in the area of KRITIS. In relation to these, an active patch management, encrypted communication standards as well as a User Rights Management (URM) via RADIUS are available in the device! This also includes signed firmware updates, security logging and active protection against brute force attacks. All this contributes to a secure operation in your IT environment!

The multimes F144-PQ has been developed for measurements performed in public grids, as well as for recording PQ data in industrial environments, up to 690 V (L-L) measurement voltage:

- 0 No moving parts (fans, hard drives etc.)
- 0 CAT IV
- 0 Extensive storage capability (can be extended up to 32 GB by the user, permitting several years recording without connection to database)

**1 Optional: IEC61000-4-7 – 2 kHz to 20 kHz (Option B1)**

Frequency measurement of voltage and current according IEC 61000-4-7 from 2 kHz to 20 kHz. Standard IEC61000-4-7 describes the measuring of harmonics and interharmonic in power supply grids and connected devices.

**1 Optional: RCM continuous residual current monitoring (Option D1).**

**1 Temperature input for PT100 / PT1000 / KTY sensors**

## 5.2 Technical Data

- 0 ⇨ 55-inch colour display
- 0 ⇨ Keypad for basic/direct device configuration
- 0 ⇨ 1 GB internal memory (extended up to 32 GB)
- 0 ⇨ IP54 in installed condition
- 0 ⇨ Input channel bandwidth 20 kHz (voltage and current)
- 0 ⇨ 4 voltage inputs Accuracy < 0.1%
- 0 ⇨ 4 current inputs
- 0 ⇨ 5. current input for the detection of differential currents or currents of the ZGP central grounding point (CGP) (from firmware version 2.2)
- 0 ⇨ Temperature input for PT100 and PT1000 sensor (from firmware version 2.2)
- 0 ⇨ Simultaneous processing of sampled and calculated voltages and currents
- 0 ⇨ Oscilloscopic voltage and current recorder sampling rate : 40.96kHz / 10.24kHz
- 0 ⇨ Half cycle recorder:
  - power frequency, RMS of voltages and currents, voltage and current phasors,
  - power recording rate : ~10ms (50 Hz) / ~8.33ms (60 Hz)
- 0 ⇨ Powerful recorder triggering
- 0 ⇨ Online streaming of voltages and currents at 40.96 kHz sampling rate.
- 0 ⇨ Recording of power quality incidents according to DIN EN 50160; IEC61000-2-2; -2-12; -2-4
- 0 ⇨ Power buffer for voltage interruptions of up to 2 seconds
- 0 ⇨ Spectral analysis 2 kHz...20 kHz (35 frequency bands, Bandwidth = 200 Hz) of voltages and currents according (IEC 61000-4-7)
- 0 ⇨ Phase of voltage and current harmonics n=2..50
- 0 ⇨ 8 general purpose digital inputs (Triggering fault records, Recording Start / Stop, General documentation of external level)
- 0 ⇨ 4 relay outputs for protection monitoring and alarming
- 0 ⇨ EDGE function - 32 freely configurable monitoring states for monitoring and triggering all measured variables - Output as binary message or via protocol
- 0 ⇨ Free of charge analysis software WinPQ lite

### Option WinPQ – Database Software

Analysis of the data on an MYSQL-based database using the WinPQ software package.  
Permanent communication with many devices, in parallel.

## 5.2.1 Dimensions / Weight

Dimensions / Weight	
L x W x H	144 x 144 x 90 mm without terminals 144 x 150 x 110 mm with terminals
Outbreak size:	138 x 138 mm (+0,8 mm)
Weight	
Weight	1220 g

## 5.2.2 Power supply

Power supply		
Feature	US8	US9
AC Nominal range [V]	100...240 V	-
AC Operating range [V]	90...264 V	-
DC Nominal range [V]	120...320 V	24...60 V
DC Operating range [V]	108...350 V	18...75 V
Power consumption	≤ 10 W < 20 VA	≤ 10 W
Frequency Nominal	50...60 Hz	DC
Frequency Operating	40...70 Hz	DC
External fuse	6 A	6 A
Characteristics	B	B
Energy storage	2 Sec.	2 Sec.
Elektrische Sicherheit	CAT II	CAT II
IEC 61010-1:2010 & Cor.:2011, DIN EN 61010-1:2011		

Depending on the power supply unit installed, supply the meter with the correct voltage range..

### 5.2.3 Electrical safety – environmental parameter

Environmental parameter	Storage and transport	Operation
Ambient temperature	IEC 60721-3-1 / 1K5	IEC 60721-3-3 / 3K6
Limit range of operation	-40...+70 °C	-25...+55 °C
	IEC 60721-3-2 / 2K4	–
Ambient temperature	IEC 60721-3-1 / 1K5 -40...+70 °C	IEC DIN EN 61010 H1: -25...+45 °C H2/H3: -25...+50 °C
Nominal operating range	IEC 60721-3-2 / 2K4 -40...+70 °C	H1: -25...+45 °C H2/H3: -25...+50 °C
Relative humidity: 24h average	5...95 % No condensation or ice	5...95 % No condensation or ice
Solar radiations	–	700 W/m <sup>2</sup>
Vibration, earth tremors	IEC 60721-3-1 / 1M1 IEC 60721-3-2 / 2M1	IEC 60721-3-3 / 3M1

Electrical safety	
IEC 61010-1 IEC 61010-2-030	
Protection class	1
Pollution degree	2
Overtoltage category	
mains supply option	
H1	300 V / CAT II
H2/ H3	150 V / CAT II
Measurement category	300 V / CAT IV 600 V / CAT III
Altitude	≤ 2000m
IP protection class in installed condition	IP54

## 5.2.4 Spannungs-Messeingänge

Spannungseingänge	
Kanäle	$U_1, U_2, U_3, U_{N/E/4}$
Elektrische Sicherheit DIN EN 61010	300 V CAT IV 600 V CAT III
Eingangsreferenz	PE
Impedanz -> PE	10 M $\Omega$    25pF
Nenneingangsspannung $U_n$	230 VAC
Messbereichsendwert	0...480 VAC L-E
Überlastbarkeit, dauernd	600VAC
Maximaler Crest-Faktor@ $U_n$	32,2
Bandbreite	DC...20 kHz
Nenn-Netzfrequenz $f_n$	50 Hz / 60 Hz
Frequenzbereich der Grundwelle	$f_n \pm 15\%$ 42,5...50...57,5 Hz 51,0...60...69,0 Hz

Genauigkeit	
Grundschiwingung, r.m.s. $U_1 \leq 150\% U_{nom}$ $0^\circ C \leq TA \leq +45^\circ C$ : $-25^\circ C \leq TA \leq +55^\circ C$ :	$\pm 0.1\%$ v. $U_{nom}$ $\pm 0.2\%$ v. $U_{nom}$
Grundschiwingung, Phase $U_1 \geq 10\% U_{nom}$ :	$\pm 0.02^\circ$
Harmonische $n = 2 \dots 50$ , r.m.s. $U_h \geq 1\% U_{nom}$ : $U_h < 1\% U_{nom}$ :	$\pm 5.0\%$ v. $U_h$ $\pm 0.05\%$ v. $U_{nom}$
Harmonische $n = 2 \dots 50$ , Phase $U_h \geq 1\% U_{nom}$ :	$\pm 0.5^\circ$
Zwischenharmonische	

Voltage inputs	
$n = 1 \dots 49$ , r.m.s. $U_{ih} \geq 1\% U_{nom}$ : $U_{ih} < 1\% U_{nom}$ :	$\pm 5.0\%$ v. $U_h$ $\pm 0.05\%$ v. $U_{nom}$
Power frequency	$\pm 1$ mHz @ $10\% \dots 200\% U_{nom}$
Flicker DIN EN 61000-4-15:2011	Class F1
Dip residual voltage	$\pm 0,2\%$ $U_{nom}$ @ $10\% \dots 100\% U_{nom}$
Dip duration	$\pm 20$ ms @ $10\% \dots 100\% U_{nom}$
Swell residual voltage	$\pm 0,2\%$ $U_{nom}$ @ $100\% \dots 150\% U_{nom}$
Swell duration	$\pm 20$ ms @ $100\% \dots 150\% U_{nom}$
Interruption duration	$\pm 20$ ms @ $1\% \dots 100\% U_{nom}$
Voltage unbalance	$\pm 0,15\%$ @ $1\% \dots 5\%$ Measured value
Mains signalling voltage (< 3 kHz)	$\pm 5\%$ Measured value @ $U_s = 3\% \dots 15\% U_{nom}$ $\pm 0,15\%$ $U_n$ @ $U_s = 1\% \dots 3\% U_{nom}$

## 5.2.5 Current inputs

Current inputs	
Option	C30
Channels	I1, I2, I3, IN/4
Electrical safety DIN EN 61010	300 V CAT III
Input type	potential-free
Impedance	$\leq 4\text{m}\Omega$
Nominal input current $I_{\text{nom}}$	$5\text{ A}_{\text{AC}}$
Full scale range (FSR)	$10\text{ A}_{\text{AC}}$
Overload capacity permanent $\leq 10\text{s}$ $\leq 1\text{s}$	$20\text{ A}_{\text{AC}}$ $100\text{ A}_{\text{AC}}$ $500\text{ A}_{\text{AC}}$
Waveform	Jede AC
Maximum crest factor@ In	3
Bandwidth	25 Hz...20 kHz
Tightening torque	2 Nm

Accuracy	
Fundamental, r.m.s..	$I1 \geq 10\% \text{ FSR:}$ $\pm 0.1\% \text{ v. } I1$ $I1 < 10\% \text{ FSR:}$ $\pm 0.01\% \text{ v. FSR}$
Fundamental, Phase	$I1 \geq 10\% \text{ FSR: } \pm 0.1^\circ$
Harmonic $n = 2 \dots 50$ , r.m.s. $I_h \geq 3\% I_{\text{nom}}:$ $I_h < 3\% I_{\text{nom}}:$	$\pm 5.0\% \text{ v. } I_h$ $\pm 0.15\% \text{ v. } I_{\text{nom}}$
Harmonic $n = 2 \dots 50$ , Phase $I_h \geq 3\% I_{\text{nom}}:$	$\pm 0.5^\circ$
Interharmonic $n = 1 \dots 49$ , r.m.s. $I_{ih} \geq 3\% I_{\text{nom}}:$ $I_{ih} < 3\% I_{\text{nom}}:$	$\pm 5.0\% \text{ v. } I_{ih}$ $\pm 0.15\% \text{ v. } I_{\text{nom}}$

## 5.2.6 Residual current monitor (RCM)

Residual current monitor (RCM) – (from firmware version 2.2)	
Nominal current	30 mA
Impedance	4 Ω
Overload capacity	5 A (1 sec.)
Resolution	24 bit ADC

## 5.2.7 Binary inputs / binary out-puts

Binary outputs (BO)	
4 binary outputs	3 x closer 1 x changeover
Contact specification (EN60947-4-1, -5-1)	3 x SPST (Single Pole Single Throw)
Configuration	1 x SPDT (Single Pole Double Throw)
Nominal voltage	250 VAC
Nominal current	6 A
Nominal load AC1	1500 VA
Nominal load AC15, 230 VAC	300 VA
Interrupting power	
DC1, 30/110/220 V	6/0,2/0,12 A
Number of switching operations AC1	≥ 60·10 <sup>3</sup> electrical
Electrical Isolation	Isolated from all internal potentials
Electrical safety EN 61010	300 V

Binary inputs (BI)	
8 binary inputs Range	0 V...250 VAC / VDC
– H – Level	> 35 V
– L – Level	< 20 V
Signal frequency	DC...70 Hz
Input resistance	> 100 kΩ
Electrical isolation	Optocoupler, electrically isolated

### Connection cable to be used:



- Provide fuses for protection for CAT II
- No mix of touchable and dangerous active circuits
- Connecting cables must be designed for a temperature of at least 62 °C

## 5.2.8 Temperature input

Temperature input PT 100 / PT 1000 / KTY (FW Version 2.2)	
Contacting measurement sensor (software setting)	2 wire 3 wire 4 wire
Update Rate	1 Sec. / 1 Hz
Resolution	15 Bit
Burden	1,9 kΩ
Accuracy	0.05% FSR

## 5.2.9 Protective earth

The device has a protective earth, which also serves as reference potential for the voltage inputs.

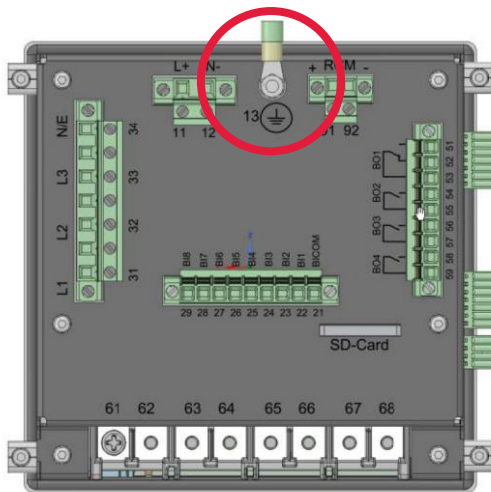

The protective  is marked with X1 / 13 on the measuring instrument.

Connect the earth cable to terminal X1 / 13 on the meter and tighten the screw. Use an eyelet terminal for the connection and make sure it is tight!



**DANGER!**

**Danger to life due to electric shock!**

Incorrect connection of this measuring instrument can lead to death, serious injury or fire hazard!

- The protective earth must always be connected to PE potential.
- The protective earth must not carry a dangerous voltage under any circumstances.

### 5.2.10 Storage of measured values

Storage of measured values	
Internal memory	1024 MB
SD memory card	1 GB to 32 GB

### 5.2.11 Communication Protocols

Communication Protocols
<input type="checkbox"/> MODBUS RTU
<input type="checkbox"/> MODBUS TCP
<input type="checkbox"/> IEC60870-5-104 (Option P1)
<input type="checkbox"/> IEC61850 (Option P2)

### 5.2.12 Time synchronization interface

Time synchronization protocols (Receive / Slave)
<input type="checkbox"/> IEEE1344 / IRIG-B000..007
<input type="checkbox"/> GPS (NMEA +PPS)
<input type="checkbox"/> DCF77
<input type="checkbox"/> NTP

### 5.2.13 Communication Interfaces

Interfaces	
Ethernet	RJ45 (10/100 MBit)
USB	USB – Type-C
2 * RS232/RS485 on terminals	Switchable

**NOTICE!****Property damage due to unauthorized IT access via network interface!**

- IT security guidelines for the place and purpose of use must be observed!
- IT security settings of the device must be observed!

**LAN-, COM interface**

- Even when disconnected, all COM and LAN connecting cables must not fall below the insulation distance to dangerous parts.
- It must not be possible to disconnect individual wires from the clamp.
- Pull the plugs only directly on the housing, never on the cable..
- Make sure that the connection cable is fixed or strainrelieved.

### 5.3 Mechanical design

The multimes F144-PQ is used as a panel-mounted device and fulfils IP54 when installed. All connections are accessible via Phoenix terminals. With the exception of the current and voltage inputs, the connections are made using plug-in terminal technology. A TCP/IP interface (RJ 45 LAN connection) and a USB interface (type C socket) are available for communication. In addition to the internal memory of 1 GB, the device memory can be expanded by a further 32 GB via an external memory card.

The memory card can also be used to easily read out measurement data from the instrument and transmit it to an evaluation PC.

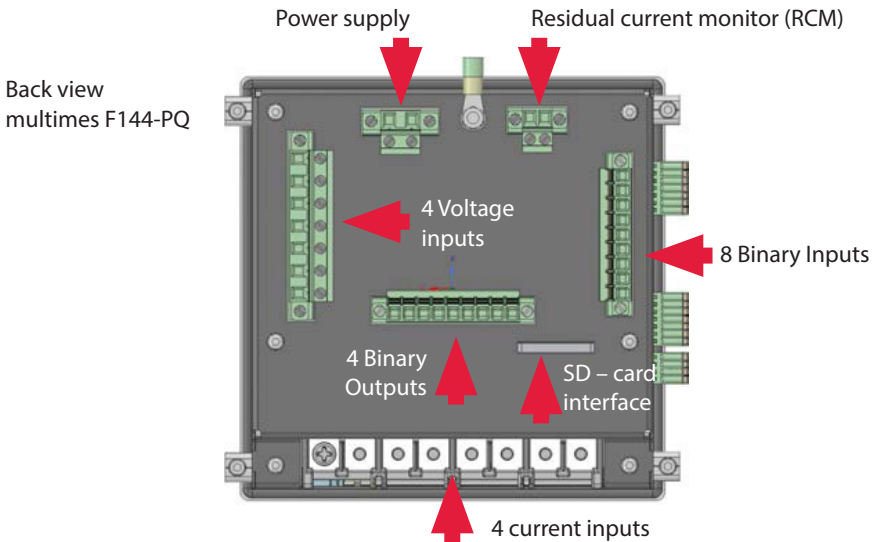

Side view left  
multimes F144-PQ

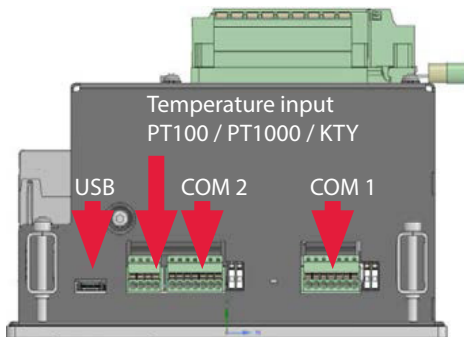

### 5.3.1 Battery

Side view right  
multimes F144-PQ

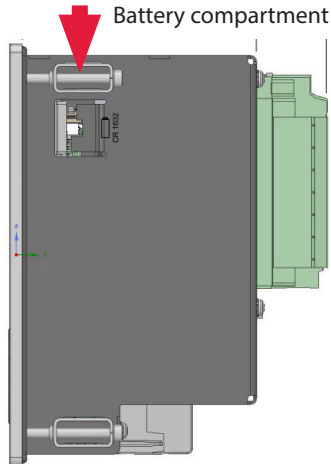

#### 1 Changing the battery:

The service life of the battery is > 5 years and is only required for the RTC time if there is no time synchronization. A battery change does not affect the operation of the device when the mains supply is connected, as the device is supplied with voltage internally.

Pull the battery out of the housing and insert a new battery..

#### 1 Battery type:

Li- button cell CR1632

## 5.4 Terminal strip number multimes F144-PQ

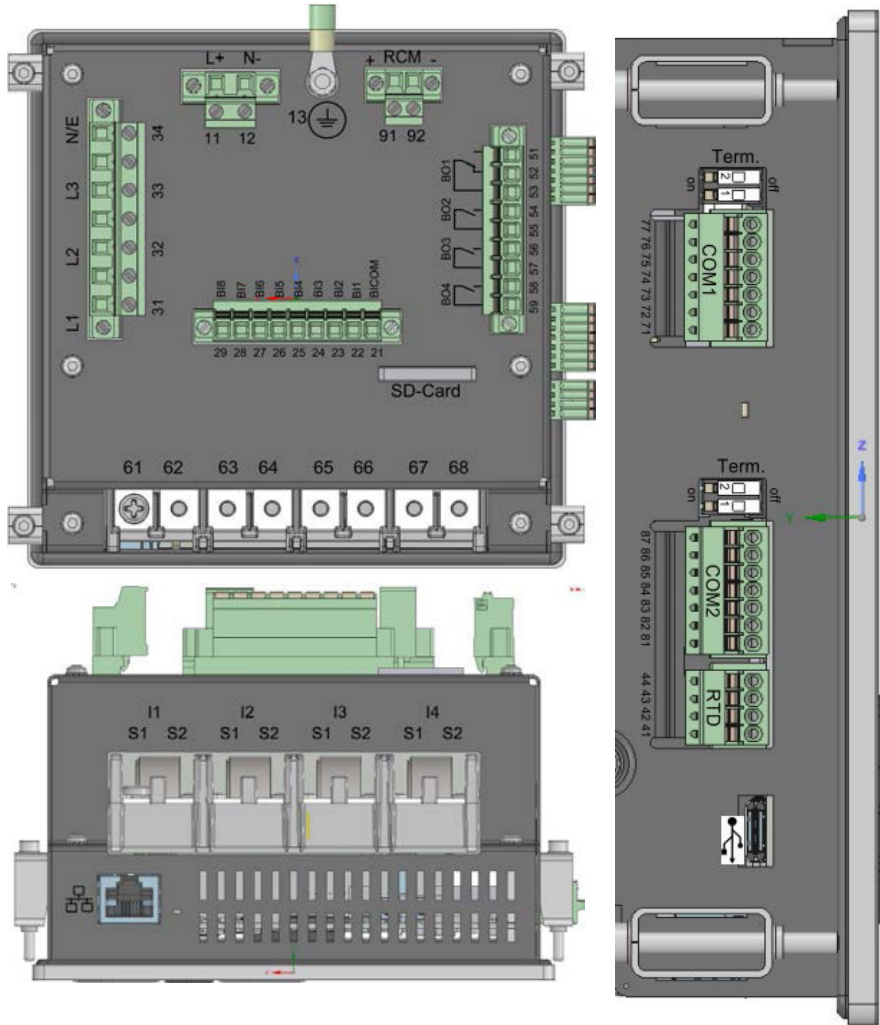

Terminal strip no.	Designation		Function	Terminal no.	cross section mm <sup>2</sup>	Stripping length mm	Torque in Nm
X1	Auxiliary voltage	UH	L (+)	11	0,2...2,5	10	0,5...0,6
			N (-)	12	0,2...2,5	10	0,5...0,6
X1	Ground	GND	PE	13	ring terminals M4	-	0,5...0,6
X2	Binary input	BICOM	-	21	solid: 0,2...2,5  flexible: 0,2...2,5	10	0,5...0,6
		B1	+	22		10	0,5...0,6
		B2	+	23		10	0,5...0,6
		B3	+	24		10	0,5...0,6
		B4	+	25		10	0,5...0,6
		B5	+	26		10	0,5...0,6
		B6	+	27		10	0,5...0,6
		B7	+	28		10	0,5...0,6
B8	+	29	10	0,5...0,6			
X3	Phase voltage L1 (AC)	U1	L1	31	0,2...2,5	10	0,5...0,6
	Phase voltage L2 (AC)	U2	L2	32		10	0,5...0,6
	Phase voltage L3 (AC)	U3	L3	33		10	0,5...0,6
	Neutral point voltage (AC)	U4	N/E	34		10	0,5...0,6
X4	PT100/PT1000/KTY Temperature input	T1		41	0,14...0,5	10	0,5...0,6
				42		10	0,5...0,6
				43		10	0,5...0,6
				44		10	0,5...0,6
X5	Binary output	R1	NO contact (+)	51	solid: 0,2...1,5  flexible: 0,2...2,5	10	0,5...0,6
			NC contact (+)	52		10	0,5...0,6
			Pol (-)	53		10	0,5...0,6
		R2	NO contact (+)	54		10	0,5...0,6
			Pol (-)	55		10	0,5...0,6
		R3	NO contact (+)	56		10	0,5...0,6
			Pol (-)	57		10	0,5...0,6
		R4	NO contact (+)	58		10	0,5...0,6
Pol (-)	59		10	0,5...0,6			

Continuation of table on next page

Continuation of the table

Terminal strip no.	Designation		Function	Terminal no.	cross section mm <sup>2</sup>	Stripping length mm	Torque in Nm
X6	Phase current L1	I1	S1 (K)	61	ring terminals 1,5–4 mm <sup>2</sup>	10	0,5...0,6
			S2 (L)	62			
	Phase current L2	I2	S1 (K)	63		10	0,5...0,6
			S2 (L)	64			
Phase current L3	I3	S1 (K)	65	-	0,5...0,6		
		S2 (L)	66				
	Neutral / sum current	I4	S1 (K)	67	10	0,5...0,6	
			S2 (L)	68			
X9	RCM - Input	I5	+	91	solid: 0,2...2,5	10	0,5...0,6
			-	92	flexible: 0,2...2,5	10	0,5...0,6

### 5.4.1 Assembly instructions

The multimess F144-PQ is used as a panel-mounted device and fulfils IP54 in the installed condition. Mounting must be carried out with the following cut-outs and minimum distances as shown in the figure below. The maximum thickness of the panel for multimess F144-PQ installation is 8mm.

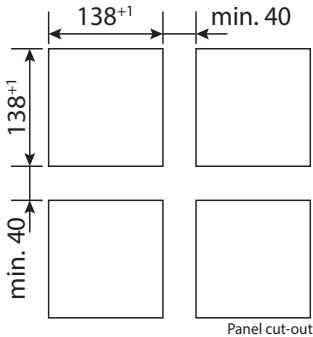

For mounting the multimess F144-PQ four mounting brackets are included in the scope of delivery. These must be snapped into the housing of the multimess F144-PQ at all four corners (see picture below). The clamps must then be screwed against the panel with a maximum torque of 5 Nm using an Allen key (2.5 mm) on the back of the multimess F144-PQ to ensure that the multimess F144-PQ is securely mounted in the panel cut-out.



Mounting bracket for multimess F144-PQ



Mounting bracket engaged on multimess F144-PQ

## 5.5 Supply Voltage Connections

The multimess F144-PQ is available in three different supply voltage versions. Please take the correct supply voltage from the type label before connection.

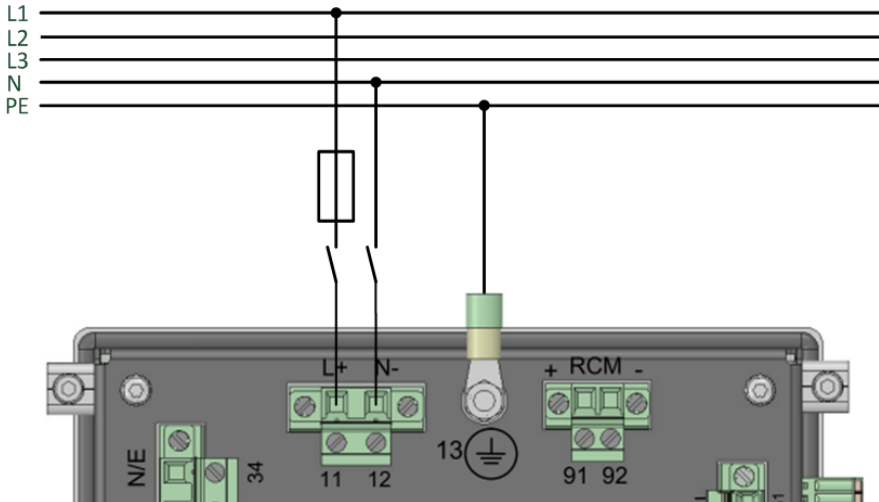

Example of connection to 230 V AC with feature

After connecting and switching on the power supply, the status LED lights up red, changes to green and the display starts in the commissioning wizard.t.

 <b>DANGER!</b>	<b>Danger to life due to electric shock!</b>
<p>Serious personal injury or death may result from:</p> <ul style="list-style-type: none"> <li>● Touching bare or stripped wires that are energised.</li> <li>● Touching dangerous inputs on the device.</li> <li>➤ Make sure that the device is connected in a deenergized state.</li> <li>➤ Ensure that all connecting cables are fixed and strain relief is provided.</li> <li>➤ All cable requirements of the terminal blocks must be observed (e.g. stripping length of the cables).</li> </ul>	

**NOTICE!****Material damage due to non-observance of the connection conditions or impermissible overvoltages!**

Failure to comply with the connection conditions or exceeding the permissible voltage range may damage or destroy your device.

Before applying the supply voltage to the device, the following points must be observed:

- Voltage and frequency must correspond to the specifications on the type label! Observe the limit values as described in the technical data (see chapter 5.2)!
- Observe features of the device H1 / H2 / H3
- In the building installation, the supply voltage must be provided by a listed miniature circuit breaker and fuse that meets the requirements of IEC 60947-1 and IEC 60947-3!
- The miniature circuit breaker
  - be easily accessible to the user and installed close to the device.
  - Label for the respective device.
- Do not take the supply voltage at the voltage transformers.
- Provide a fuse for the neutral conductor if the neutral connection of the source is not earthed.

## 5.6 Mains connection for multimes F144-PQ

The mains connection of the multimes F144-PQ depends on the type of mains in which the measurement is to be made.

The multimes F144-PQ is designed for direct measurement in low voltage (3 phase / 4 wire connection) for low voltage networks (TN, TT and IT networks) or for residential and industrial applications. A special form of low voltage measurement is the measurement 4-wire / 1 phase connection with which three independent voltage circuits and current circuits can be measured with the same ground conditions.

For medium and high voltage the device can be connected via suitable transformers. A connection with three voltage and current transformers is possible as well as the connection via transformer saving circuits (V-circuit, Aron circuit).

In addition, current measurements with small signal inputs are possible with the corresponding sensor transformers (hardware features C40, C44 and C45).



**WARNING!**

**Personal injury and damage to property due to non-observance of the safety regulations**

➔ Before making any connections, please read this manual thoroughly and follow the safety measures described here.

### 5.6.1 3-phase / 4-wire connection

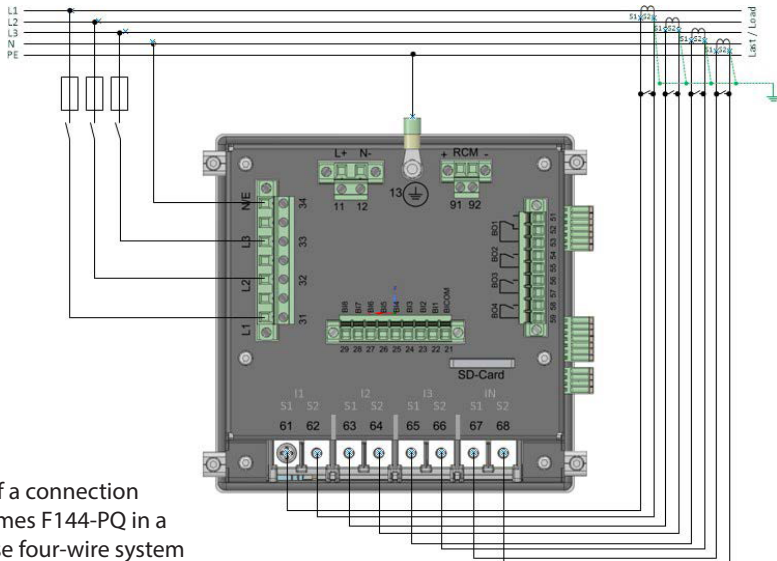

Example of a connection for a multimes F144-PQ in a three-phase four-wire system

## 1 Voltage connections

- 0 The voltage connections must be made as shown in the circuit diagram above
- 0 If no N conductor connection is available, connect connections E and N together.
- 0 Make sure that the switching mode (4-wire) is set (settings are described in chapter 6.3).

## 1 Stromanschlüsse

The multimes F144-PQ is designed for measuring circuits. The current transformer ratio is factory-set to nominal current (e.g. 5 A) and must be adapted to the transformers used if necessary. Only alternating currents can be measured, not direct currents. The corresponding transformers can be obtained from KBR.



**DANGER!**

**Danger to life due to electric shock!**

Attention dangerous contact voltage!

Flashover and high short-circuit currents possible in CAT III and CAT IV!

- Ensure that the PE conductor (earthing) is connected to the multimes F144-PQ
- Before starting work, check that no voltage is present!
- Provide protective equipment for CAT II, CAT III or CAT IV.
- High-load fuses >10 kA or >50 kA must be used in accordance with the CAT.
- Short-circuit current transformers before starting work.
- Ensure that all connecting cables are fixed and strain-relieved.
- All cable requirements of the terminal blocks must be observed (e.g. stripping length of the cables).



## 1 Voltage connections

- If no N conductor connection is available, connect connections E and N together.
- Make sure that the switching mode (4-wire) is set

## 1 Current connections

- If no neutral conductor current is available in the 3-phase / 4-wire network, the S2 current inputs of the PQI-DE must all be short-circuited and the S2 terminals of the current transformers used must be connected to S1.
- The multimes F144-PQ is designed for measuring circuits.



**DANGER!**

**Danger to life due to electric shock!**

Attention dangerous contact voltage!

Flashover and high short-circuit currents possible in CAT III and CAT IV!

- Ensure that the PE conductor (earthing) is connected to the multimes F144-PQ.
- Before starting work, check that no voltage is present!
- Provide protective equipment for CAT II, CAT III or CAT IV.
- High-load fuses >10 kA or >50 kA must be used in accordance with the CAT.
- Short-circuit current transformers before starting work.
- Ensure that all connecting cables are fixed and strain-relieved.
- All cable requirements of the terminal blocks must be observed (e.g. stripping length of the cables).

### 5.6.3 4-wire / 1-phase

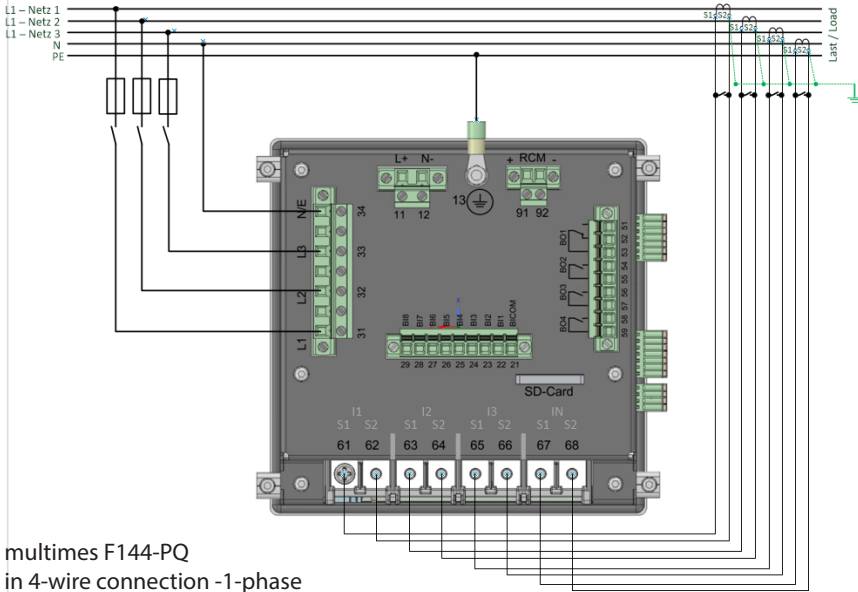

multimes F144-PQ  
in 4-wire connection -1-phase

In the 4-wire network / 1-phase circuit type, no wire-conductor events and three phase network events are evaluated. Voltages with the same earth potential can be connected (e.g. three networks with phase L1) and any currents can be connected.



**DANGER!**

**Danger to life due to electric shock!**

Attention dangerous contact voltage!

Flashover and high short-circuit currents possible in CAT III and CAT IV!

- ➔ Ensure that the PE conductor (earthing) is connected to the multimes F144-PQ.
- ➔ Before starting work, check that no voltage is present!
- ➔ Provide protective equipment for CAT II, CAT III or CAT IV.
- ➔ High-load fuses >10 kA or >50 kA must be used in accordance with the CAT.
- ➔ Short-circuit current transformers before starting work.
- ➔ Ensure that all connecting cables are fixed and strain-relieved.
- ➔ All cable requirements of the terminal blocks must be observed (e.g. stripping length of the cables)

## 5.6.4 3-phase / 3-wire connection

### 5.6.4.1 Connection to secondary transformer

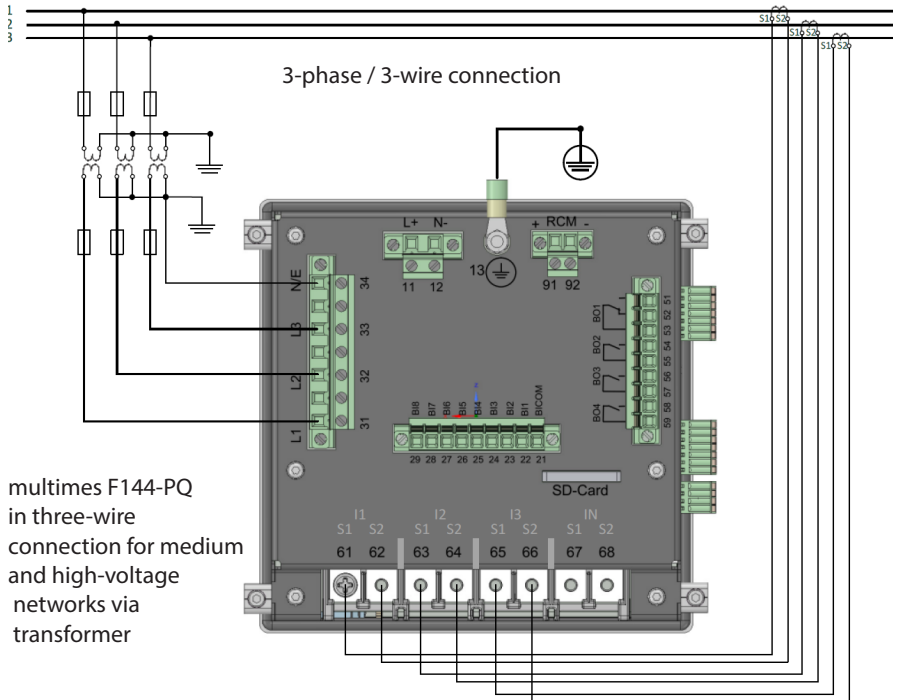

multimes F144-PQ  
 in three-wire  
 connection for medium  
 and high-voltage  
 networks via  
 transformer

#### 1 Voltage connections

- 0 Make sure that the measuring cable N/ E is connected to terminal 34 for each measurement. This is usually the earthing point of the voltage transformer.
- 0 Ensure that the switching mode (3-wire) is set (settings are described in chapter 6.3).
- 0 Set the voltage transformation ratio.
- 0 Enter the nominal voltage of the conductor-conductor voltage.

#### 1 Current connections

- 0 Set current transformer ratio.

Connection multimes F144-PQ Current IN in the 3-wire network

If a current is connected to the IN input in the 3-wire network, it is not physically measured. The IN current is always calculated in three-wire operation.

**DANGER!****Danger to life due to electric shock!**

Attention dangerous contact voltage!

Flashover and high short-circuit currents possible in CAT III and CAT IV!!

- Ensure that the PE conductor (earthing) is connected to the multimes F144-PQ.
- Before starting work, check that no voltage is present!
- Provide protective equipment for CAT II, CAT III or CAT IV.
- High-load fuses >10 kA or >50 kA must be used in accordance with the CAT.
- Short-circuit current transformers before starting work.
- Ensure that all connecting cables are fixed and strain-relieved.
- All cable requirements of the terminal blocks must be observed (e.g. stripping length of the cables)
- According to DIN VDE 0414, all converters with an operating voltage of 1000 V grounded.

## 5.7 Additional interfaces

### 5.7.1 RS232 / RS485 Interfaces

The multimes F144-PQ has two serial interfaces which can be used either as RS232 or RS485. The changeover and functions are determined by the parameterization via the WinPQ Lite software or the display.

#### 1 The following functions are available::

- 0 Modbus (RS232 / RS485)
- 0 Time signals from various external timers' further information can be found in: Device Instructions chapter 6.5.2

#### 5.7.1.1 Connection and Termination RS232/RS485 Interface

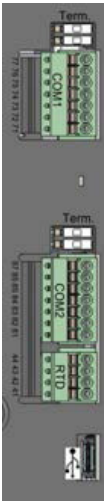
Picture	Interface	Terminal No.	function
	COM 1 (X7)	77	RS485 Pos (A)
		76	RS485 Neg (B)
		75	CTS
		74	RxD
		73	GND
		72	RTS
		71	TxD
	COM 2 (X8)	87	RS485 Pos (A)
		86	RS485 Neg (B)
		85	CTS
		84	RxD
		83	GND
		82	RTS
		81	TxD

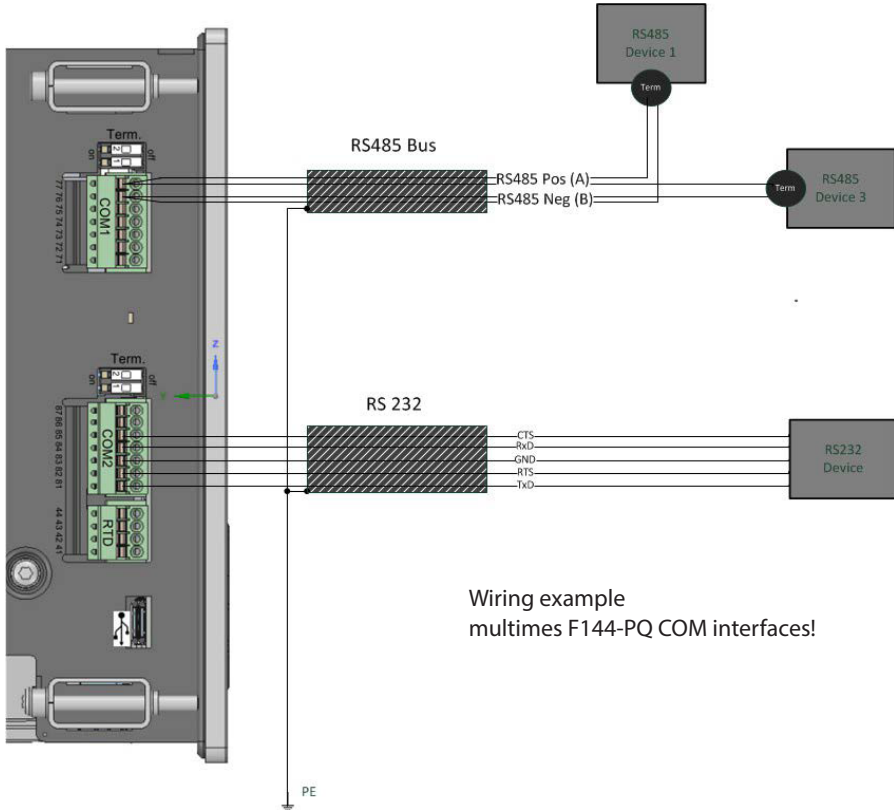

Use a twisted shielded cable for the RS232 and RS485 interfaces. The shields of all cables must be connected to a voltage-free ground as close as possible to the device!

Please make sure that the maximum cable length of 1200 m for RS485 and 15 m for RS232 is not exceeded!!

### 1 Termination RS485

The first and last station on the bus must be terminated. Dip switches "Term 1" for the Com 1 interface and "Term 2" for the Com2 interface is provided on the multimes F144-PQ for this purpose. Bus termination is switched on with "ON"

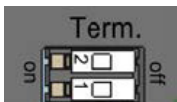

- Set both dips switches to ON: Bus termination is switched on.
- Both dips switches set to Off : Bus termination is switched off.

### 5.7.1.2 Connection of PQI-DE as Modbus Master in a bus

The measuring device can also function as Modbus RTU master in a bus. Notes on parameterization and operation can be found in the device instructions 8.1 and 8.2. When setting up the bus, the following notes should be observed:

#### 1 RS-485

- 0 Max. 32 participants allowed (Gateway plus 31 RTU-Slaves)
- 0 Connect wire RS-485A, RS-485B and GND (see chapter 5.7.1.1)
- 0 1 terminating resistor (120...150 Ohm) each at the beginning and end of the backbone
- 0 Ground the shield of the cable on one side only (to PE)!
- 0 Maximum length of the backbone: approx. 700 m (at low baud rates also up to 1200 m)

#### 1 RS-232

- 0 Only 2 participants allowed (Gateway plus one RTU-Slave)
- 0 Connect wires RXD, TXD and GND (see chapter 5.7.1.1)
- 0 Ground the shield of the cable on one side only (to PE)!
- 0 Maximum length approx. 20m

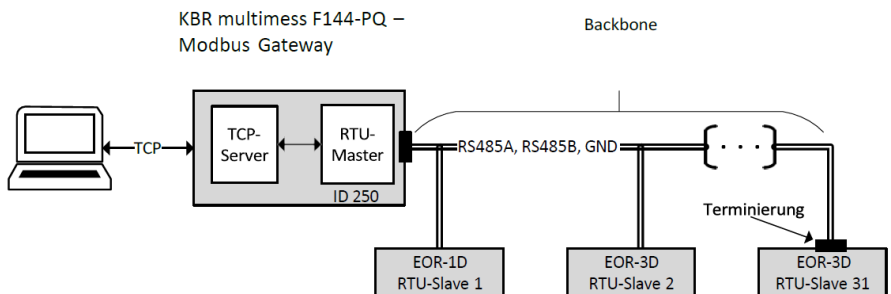

Figure 1: Exemplary connection of a RS485 bus with Modbus gateway

## 5.7.2 Temperature input PT100/PT1000

The multimes F144-PQ has a temperature input for recording process temperatures. When connecting the sensor, please note that a shielded cable with twisted pairs of wires of the same length should be used.

In addition, the total load of 1,9 k $\Omega$  including the thermocouple must not be exceeded.

### The multimes F144-PQ generally has three connection options::

#### 1 PT100in 2-wire circuit

In a 2-wire circuit, the resistance of the supply line is included in the measurement as an error.

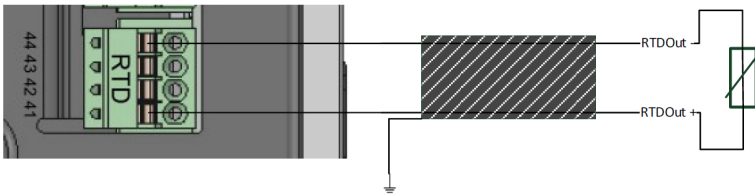

#### 1 PT100 in 3-wire circuit

The influence of the line resistance is largely compensated by a 3-wire circuit..

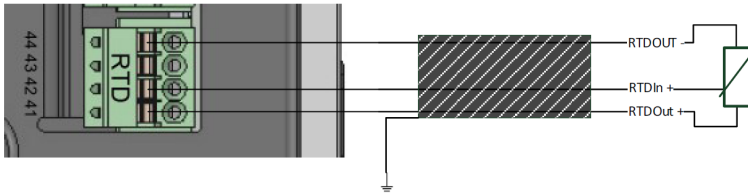

#### 1 PT100in 4-wire circuit

The 4-wire circuit completely eliminates the influence of the connecting cable on the measurement result.

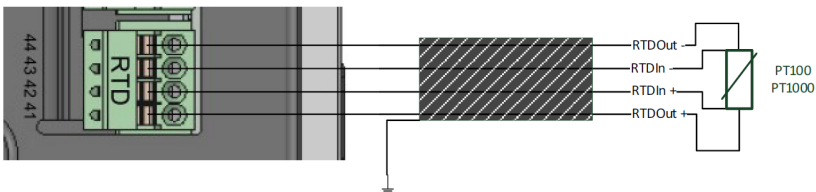

### 5.7.3 Differential current input

The multimes F144-PQ is equipped with a residual current input (RCM) for residual current monitoring on the rear panel. The input is suitable for alternating currents, for pulsating DC currents and for pure DC currents.

All external residual current transformers with a rated current of 30 mA can be connected to terminals 91 / 92.

#### 1 Differential current transformer connection

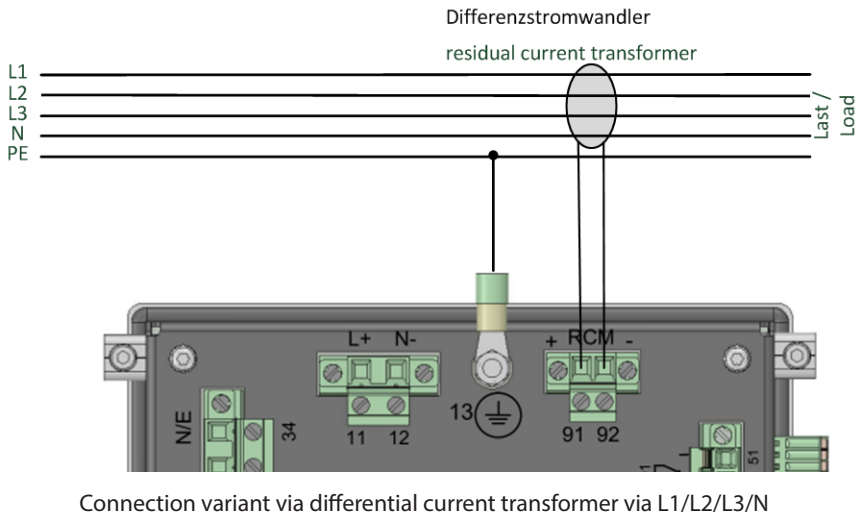
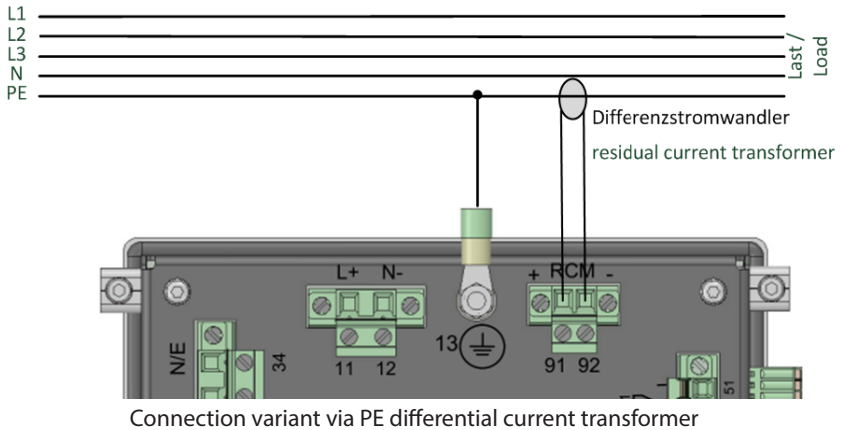

## 5.7.4 Output relays

The multimes F144-PQ has four binary outputs that can switch both direct current and alternating current.

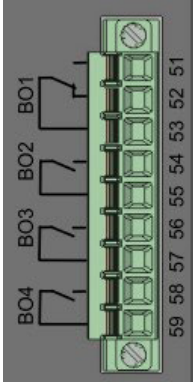

The following technical functions can be realised:

- Relay B01 - Watchdog relay Self-monitoring of the measuring device
- Relay B02 to B04 - Trigger event message Trigger options and parameterisation.

The binary outputs can switch AC loads directly up to the specified technical specifications!

The connection is made directly via terminals X5! The terminal assignments are specified in chapter 5.4.



**DANGER!**

**Danger to life due to electric shock!**

Attention dangerous contact voltage!

Flashover and high short-circuit currents possible in CAT III and CAT IV!!

- Before starting work, check that no voltage is present!
- Provide protective equipment for CAT II, CAT III or CAT IV.
- Ensure that all connecting cables are fixed and strain-relieved.
- All cable requirements of the terminal blocks must be observed (e.g. stripping length of the cables)

### 5.7.5 Binary Inputs

The multimes F144-PQ vhas eight binary inputs which can be assigned to the following functions:

- 0 Recorder trigger
- 0 Trigger Interval of power average values
- 0 For recording control

The binary inputs are designed for the voltage 48 - 250 V AC/DC - feature M1 and up to 24 V DC - feature M2, whereby the level detection is set to the following characteristic values:

#### 1 230 V - Eingänge

- 0 High Pegel > 35 V
- 0 Low Pegel < 20 V



**DANGER!**

**Danger to life due to electric shock!**

Attention dangerous contact voltage!

- Before starting work, check that no voltage is present!
- Ensure that all connecting cables are fixed and strain-relieved.
- Table requirements of the terminal blocks must be observed (e.g. stripping length of the cables).

## 5.8 Measurement / Functions

multimes F144-PQ complies with the automatic event detection and measurement standards, which are:

Standard	Description
EN50160	European power quality standard
IEC61000-2-2	EEMC standards in low voltage grids
IEC61000-2-12	EMC standards in medium voltage grids
IEC61000-3-6/7	EMC standards in high voltage grids
IEC61000-2-4 (Klasse 1, 2, 3)	Industrial EMC standards
IEC61000-3-2/3	Limits for harmonic current emissions
NRS048/IEEE519	International power quality standards
IEC61000-4-30 Class A Edition 3	Methods of measuring power quality
IEC61000-4-7	EMC standards up to 18,6 kHz
IEC61000-4-15	Flicker measurement

### 5.8.1 Continuous Recording:

Five fixed and two variable measurement time intervals are available for continuous recording. All measured values can be freely activated or deactivated in the data classes. More detailed information about the available measurands per data class can be found in the technical datasheet.

- 10/12 periods (200 ms)
- 150/180 periods (3 sec.)
- 1 sec
- N\*min  
(can be set from 1 minute to 60 minute)
- 10/12 periods (200 ms)
- 10 min
- N\*sec  
(can be set from 2 seconds to 60 seconds)
- 2 hrs.

## 5.8.2 PQ-Events

trigger quantity	lower	upper
voltage dip (T/2)	✓	
voltage swell (T/2)		✓
voltage interruption (T/2)	✓	
voltage rapid voltage change (T/2)	sliding average filter mean +/- threshold	
voltage change (10 min)	✓	✓
voltage unbalance (10 min)		✓
mains signalling voltage (150/180T)		✓
voltage harmonics (10 min)		✓
voltage-total-distortion (THD) (10 min)		✓
voltage short term flicker PST (10 min)		✓
voltage long term flicker PLT (10 min)		✓
power frequency (10 s)	✓	✓

## 5.8.3 Recorder triggering

trigger quantity	lower	upper	step
r.m.s. phase voltages (T/2)	✓	✓	✓
r.m.s. phase-phase voltages (T/2)	✓	✓	✓
r.m.s. residual/neutral-ground voltage (T/2)		✓	✓
Positive sequence voltage (T/2)	✓	✓	
Negative sequence voltage (T/2)		✓	
Zero sequence voltage (T/2)		✓	
Phase voltage phase (T/2)			✓
phase voltages wave shapes (wave shape filter)	+/- threshold		
phase-phase voltages wave shapes (wave shape filter)			
residual/neutral-ground voltage wave shape (wave shape filter)			
r.m.s. phase currents (T/2)	✓	✓	✓
r.m.s. total / neutral current (T/2)		✓	✓
Power frequency (T/2)	✓	✓	✓
Binary inputs (debounced)	rising, falling slope		
Command	external		

## 5.8.4 Memory management

The multimes F144-PQ is equipped with one gigabyte of internal memory and intelligent memory management. This ensures that the oldest data records are always overwritten by the most current data according to the First in First out principle (FiFo).

**By default, the measuring device is divided into two memory areas:**

- 0 Continuous measurement data with 50% of the total memory
- 0 Fault record and events and other asynchronous measurement data



In the standard parameterization with approx. 800 measured variables in the 10 min data class, the device is able to continuously and seamlessly record all 800 measured variables such as current, voltage, harmonics and power over 140 weeks.

### 1 Memory allocation

The memory distribution of the multimes F144-PQ uses the internal 1 GB memory in a circular ring buffer for all measurement data.

**The circular buffer is divided as follows:**

- 0 512 MB circular memory for long-term measurement data
- 0 320 MB circular memory for disturbance records (oscilloscope images; ½ periods RMS values)
- 0 16 MB circular memory for log files and power quality events

In addition, a maximum of 512 files can be saved in each circular memory area.



It is possible to change the memory allocation using parameters. Please contact the support of KBR.

### 5.8.4.1 Memory Expansion with SD Card

If a SD-card is inserted in the device, you have to choose between different methods of using the SD-card:

- KCopy all data of the last 7 days
- Copy all data of the last 30 days
- Copy all data a complete snapshot of the whole internal memory
- Circular (ext.) = the SD-card will stay in the device and will be filled in a circular memory. If the SC-card is bigger than one gigabyte, the time period of the SD-card is much longer than into the multimess F144-PQ. (extended Memory)

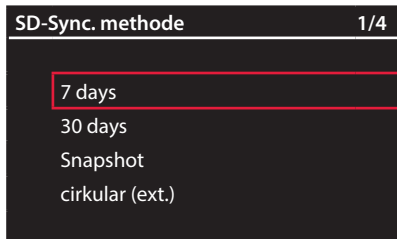

Confirm with "OK" and the PQI-DE will start automatically to copy the selected internal memory onto the SD card.



The minimum size of an external memory card is 1 GB. The device can manage memory cards up to a max of 32GB.

In the display menu Memory the progress of the copy process is shown.

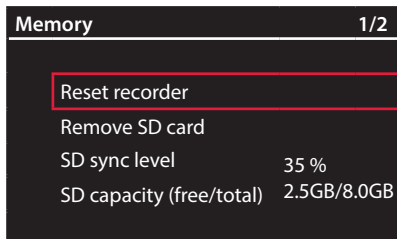

➡ To remove the memory card, operate the "Remove SD card" function.

The "Remove SD card" function stops the copying function for the measuring data of the internal memory to the SD memory card and releases the card for removal.

<b>NOTICE!</b>	<p><b>Data loss!</b> Defect / loss of data due to incorrect operation.</p> <p>➡ Before removing the SD card, the "Remove SD card" function must be activated to ensure that no data is lost!</p>
----------------	--

## 6. Operation of the multimes F144-PQ

### 6.1 Getting started

When the power analyser multimes F144-PQ is put into operation for the first time, the instrument will appear in a guided "Wizard " mode. The operator is automatically guided through the initial commissioning of the instrument.

This Wizard must be performed once after the PQ meter has been fully connected.

	<p>It is recommended to perform the wizard only after all wiring has been completed so that no incorrect measurement data is recorded due to the absence of measurement voltage, currents or parameters that have not been entered..</p>
---	--

	<p>Since firmware version 2.0 the recording of the measurement data is only started after the complete completion of the wizard!</p>
---	--

### 6.2 Initial Setup - Operation of the Assistant

The following actions can be performed using the navigation cross on the multimes F144-PQ:

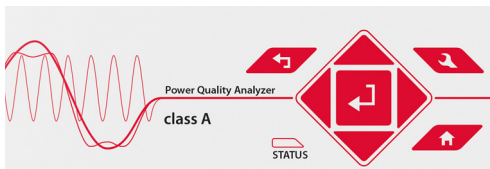

- ▶ **Arrow key right / down:** Continue in wizard
- ▶ **Arrow key left / up:** Back in wizard
- ▶ **Enter key**  : Changing parameters

## 6.3 First commissioning - wizard - procedure

### 6.3.1 Wizard setting: Language

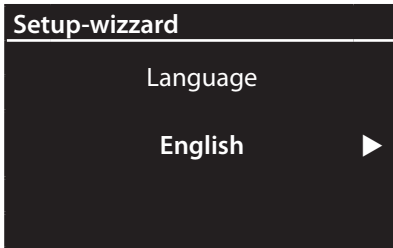

0 Selection of display language

### 6.3.2 Wizard setting: Power Quality standard

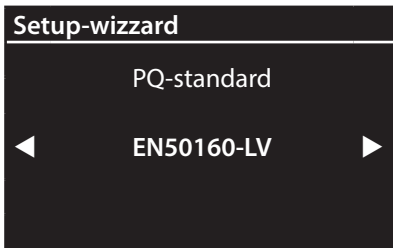

0 Selection of the Power Quality standard

Press the key  to switch between the following PQ standards.

– Low-voltage grid – TN system =>  
EN50160-LV

– Low-voltage grid – IT system =>  
EN50160-LV-IT

– Medium-voltage grid =>  
EN50160-MV

– High-voltage grid =>  
EN50160-HV

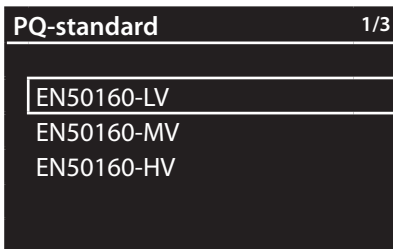

Automatic basic settings and limit values for the following voltage level according to EN 50160:

The selection of the voltage level has an influence on which measures should be recorded, on the thresh-olds and also at the IEC61850 Interface which data can be used at IEC61850 Interface.

### 6.3.3 Wizard setting: Net type

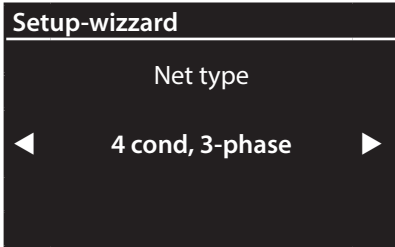

#### 0 Grundeinstellung des Netzanschlusses

	<p>If the power quality standard EN50160-NS-IT, EN50160- MS and EN50160-HS is selected, the "Mains form" wizard setting is omitted, as this is selected as "3-wire mains" by default. The setting cannot be edited due to the correct power quality evaluation (see explanation below).</p>
---	---

1 For more information on the mains connection, see **Hardware connection**

#### 0 Net type:

Entering the grid type "3-conductor grid", "4-conductor grid" and/or "4 x 1 conductor grid" will determine how the Power Quality events are recorded.

Switch between 3-conductor and 4-conductor grids.

- In a 3-conductor grid, all events are calculated from the line-line voltages.
- In a 4-conductor grid and/or a 4 x 1 conductor grid all Power Quality events are determined from the line-earth voltages.

### 6.3.4 Wizard setting: Net frequency

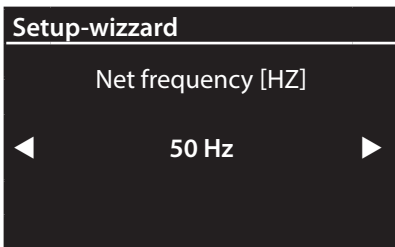

#### 0 Grid frequency

Setting grid frequency to 50 Hz or 60Hz.

### 6.3.5 Wizard setting: Voltage Transformer

**Setup-wizzard**

---

Voltage Transformer  
primary Voltage [V] P-P

◀ 20000.00 ▶

● **Primary Voltage:**

Corresponds to the primary rated voltage of the voltage transformer.

● **Sec. Voltage:**

Corresponds to the secondary rated voltage of the voltage transformer.

**Setup-wizzard**

---

Voltage Transformer  
secondary Voltage [V] P-P

◀ 100.00 ▶



The voltage transformer factor is calculated automatically!



If Power Quality standard for low voltage network (EN50160-LV & EN50160-LV-IT) is selected, the page voltage transformer is skipped, because the device can cover the complete range without transformer settings. Therefore, no input is necessary, as no voltage transformer factor has to be calculated.

### 6.3.6 Wizard setting: Voltage Grid

**Setup-wizzard**

---

Voltage Grid  
Reference voltage [V] P-P

◀ 20000 ▶

[V] P-N 11547.01

0 **Reference voltage in low voltage:**

Setting the reference voltage in the low voltage

- TN system as conductor-earth voltage in volts and in the low voltage
- IT system or medium and high voltage as conductor-conductor voltage in volts.



The non-editable parameters are calculated automatically.

### 6.3.7 Wizard setting: Current Transformer

Setup-wizzard

Current Transformer  
primary current [A]

◀ 3000 ▶

#### 0 Primary Current:

Primary nominal current of the connected current transformer.

#### 0 Sec. Current:

Secondary nominal current of the connected current transformer.

	The voltage transformer factor is calculated automatically!
---	---

Setup-wizzard

Current Transformer  
secondary current [A]

◀ 5.0 ▶

### 6.3.8 Wizard setting: Transformer Factor Equipment

Setup-wizzard

System Load  
Transformer Factor Equipm.[mV/A]

◀ 100 ▶

#### 0 Transformer Factor Equipm.:

Setting the transformer factor of Rogowski coils connected to the current input.

	The page is hidden for multimes F144-PQ with the features C30 and C31.
--	--

### 6.3.9 Wizard setting: Rated Current



#### ● Rated Current:

Setting the nominal current of the system.

	<p>Once the commissioning wizard has been completed, the transformer factor is shown with the reciprocal value in the display and the software. For conversion, see section <a href="#">7.4.3.5</a>.</p>
---	--

### 6.3.10 Wizard setting: Date, Time and Timezone

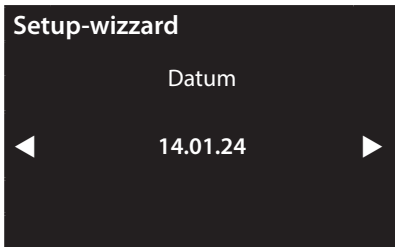

Manually enter the date and time in local time and then the time zone in which the device is installed.

You must also set whether the device calculates the summer/winter time changeover internally (INT = internal calculation)



	<p>In the factory setting, the device is set to time zone UTC+1 with auto-matic winter time changeover. The time zone and summer/winter time changeover must be adapted to local conditions.</p> <p>According to IEC61000-4-30, an external synchronization source such as NTP / DCF77 / GPS is required.</p>
--	---



### 6.3.11 Setup-wizzard: Communication settings

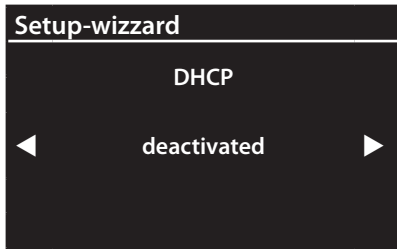

#### 0 DHCP:

**DHCP deactivated:** The device is used with a fixed IP address which have to be parameterized in the next step.

**DHCP activated:** The device gets its IP-Address direct from a DHCP Server, which has to be reachable!

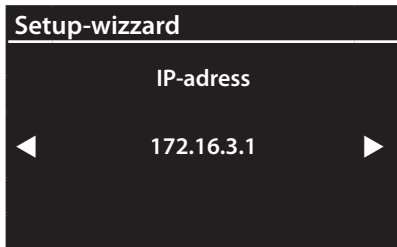

#### 0 IP address:

Entry of a fixed IP address as specified by IT.

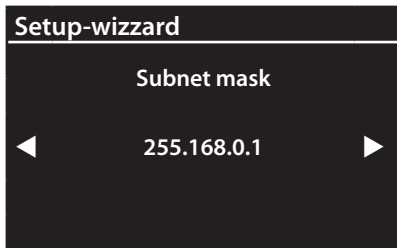

#### 0 Subnet mask:

Entering the subnet mask

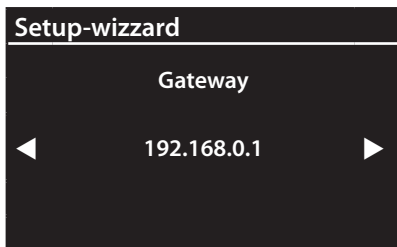

#### 0 Gateway:

Entering a gateway



As of firmware version v2.6.0, the PQI-DE supports double IP address detection. Therefore, already assigned IP addresses of the subnet cannot be used. In this case, the wizard must be run again.

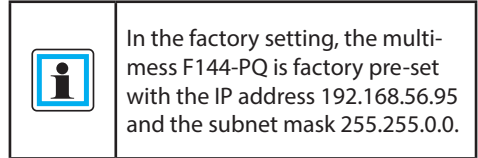

### 6.3.12 Wizard setting: Security Mode

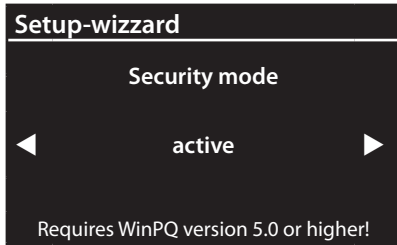

#### 0 Security Mode:



##### Active: high security mode

The device is set up in security mode. Communication is encrypted and device access is protected. The completion of the commissioning in security mode requires the setup of the necessary user accounts and must be completed with the software WinPQ or WinPQ lite with version 5.0 or higher. All details on encryption technology etc. are described in the security documentation.

##### Inactive compatible mode

The installation of devices in compatibility mode results in a non ITsecure operation of the measuring device, if no other measures for the encryption of the connection are available in the used network (e.g. VPN solutions with encryption / disconnected network or similar), because neither the communication between WinPQ software and the PQ device is encrypted nor the device access is protected.

This mode is intended for compatibility with WinPQ systems smaller than version 5 and systems with WinPQ versions 5 or higher should be operated in high security mode.

	<p>In any case, make a note of the serial number of your measuring instrument!</p>
	<p>When the SD card is inserted, an identification file with the required certificates for the recognition of the device is stored in the root directory of the SD card when the device is restarted</p>

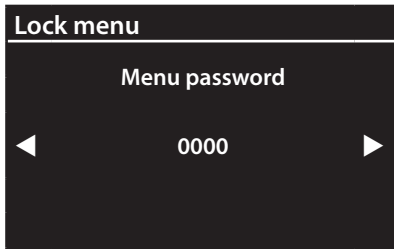

In the active security mode it is recommended to password the display in addition to the encryption.

### 6.3.13 Wizard End of commissioning

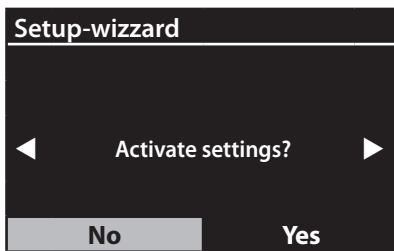

#### 0 Accept settings:

At this point all settings for the device can be accepted or the setup wizard can be cancelled.

If the wizard is aborted, the wizard will appear again and again each time the device is restarted because the necessary basic settings have not been made.

With the confirmation "Yes".

- 0 restarts the device,
- 0 the device accepts all changes,
- 0 the device deletes all old measurement data in the device memory,
- 0 many parameters are reset to factory settings.

The measurement campaign is started after the restart, all recorders are active.

## 6.4 Display

The colour display of the device provides information about the correct connection of the measuring cables and transducers and shows online data for voltages, currents, total harmonic distortion (THD), power values and energy. As well as the bar graphs for voltage and current harmonics.

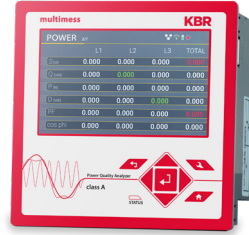

Pressing the "right" and "left" keys on the keypad will change the side of the numeric display.



Pressing the "up", "down" keys on the keypad switches to the graphical display pages. By pressing the "right", "left" keys on the keypad, the page of the graphic display changes.

If no key is operated, the screen will switch to sleep mode after 5 minutes.

### 6.4.1 Numerical display

The following screens provide online information of the measured data in numerical form:

Display page 1

U, I, P		L1	L2	L3	N/Σ
U	[V]	0.079	0.053	0.053	0.052
I	[A]	25.99	68.58	26.32	98.23
P	[W]	-0.289	+0.424	-0.215	-0.080
THD U	[%]	0.000	0.000	0.000	0.000
THD I	[%]	0.000	0.000	0.000	0.000
F	[Hz]	0.000			

- 0 Conductor-earth Voltages
- 0 Currents L1, L2, L3, N conductor
- 0 Active power with sign (+/-)
- 0 Distortion factor of voltages and currents (Total Harmonic Distortion) The THD calculation H2 to H40 or H2 to H50 is adjustable.
- 0 Mains frequency

## Display page 2

U <sub>L-L</sub>		L12	L23	L31
U	M	0.054	0.013	0.045
Extremwerte U L-L [10min]				
U <sub>max 7T</sub>	M	0.064	0.020	0.051
U <sub>min 7T</sub>	M	0.051	0.008	0.039
U <sub>max</sub>	M	0.064	0.020	0.051
U <sub>min</sub>	M	0.000	0.000	0.000

- 0 Leiter-Leiter Spannungen & Extremwerte Leiter-Leiterspannung der gewählten Datenklasse in folgenden Zeiträumen
- 0 7 Tage
- 0 Gesamte Messzeitraum, seit dem letzten Zurücksetzen



The desired data class must be set via the setup display or the software (see section 6.5.4 Basic settings or section 7.5.3.9 Statistics)! The setting made is identical for all statistical values (maximum voltage value, minimum voltage value and maximum current value).

The extreme values can be reset via the display

## Display page 3

P, Q, S		L1	L2	L3	Total
S	[VA]	2.328	3.651	1.430	7.376
Q	[VAR]	2.321	3.646	1.408	7.375
P	[W]	+0.175	+0.198	-0.249	+0.125
D	[VAR]	2.321	3.646	1.408	7.375
PF		1.000	1.000	1.000	1.000
cos phi		1.000	1.000	1.000	1.000

- 0 S: Apparent power
- 0 Q: collective reactive power (unsigned)
- 0 P: Active power
- 0 D: Distortion reactive power
- 0 PF: Power factor
- 0 Cos phi: cos Phi

### Display page 4

U <sub>L-L</sub>		L12	L23	L31
U	[M]	0.054	0.013	0.045
Extremwerte U <sub>L-L</sub> [10min]				
U <sub>max 7T</sub>	[M]	0.064	0.020	0.051
U <sub>min 7T</sub>	[M]	0.051	0.008	0.039
U <sub>max</sub>	[M]	0.064	0.020	0.051
U <sub>min</sub>	[M]	0.000	0.000	0.000

- 0 Total active energy
- 0 Active energy related (positive sign)
- 0 Active energy supplied (negative sign)
- 0 Total reactive energy
- 0 Reactive energy referred (positive sign)
- 0 Reactive energy supplied (negative sign)

### Display page 5

I <sub>max</sub> [10min]					
		L1	L2	L3	N/Σ
I	[A]	0.000	0.000	0.000	0.000
I <sub>max 1T</sub>	[A]	0.000	0.000	0.000	0.000
I <sub>max 7T</sub>	[A]	0.001	0.001	0.003	0.002
I <sub>max 30T</sub>	[A]	0.001	0.001	0.003	0.002
I <sub>max</sub>	[A]	0.001	0.001	0.003	0.002

- 0 Current and current maximum of the selected data class in the following periods:
  - 0 of the last day
  - 0 of the last 7 days
  - 0 of the last 30 days
  - 0 of the total measuring time



The extreme values can be reset via the display

### Display page 6

RCM		RCM <span style="color: green;">●</span>
IR	[mA]	0.000
Warnschwelle	[mA]	10.00
Alarmschwelle	[mA]	18.00

- 0 R: Residual Current in [mA]
- 0 Warning threshold: Threshold for state Warning in [mA]
- 0 Alarm threshold: Threshold for state Alarm in [mA]



The numerical display only appears if the function RCM is active.

### Display page 7

Recorder			
	1T	7T	30T
Oszillcoskop	0	0	0
RMS	0	0	0
PQ-Events	126	816	3432

The number of PQ events, oscillographs and RMS records that occurred for the last day, week and month appear on the instrument display.)



The break of the event counters is at 24:00 hrs at the change of day.

### Display page 8

Device information	
Firmware	2.1.0
Build	14057
Date	15.08.19
Time	14:22:54
S/N	19025758
A/N	1197801

- 0 Current firmware multimes F144-PQ
- 0 Date & time from device
- 0 Serial & article number

### Display page 9

Licence information	
Sampling rate	<input type="checkbox"/> 40 kHz
SCADA	<input checked="" type="checkbox"/> IEC60870-5-104
	<input type="checkbox"/> IEC61850

**Active device licence is displayed.**

Example device has a 40 kHz sampling rate licence and can be connected via IEC60870-5-104 control technology connection.

Display page 10

**Security**

RSA2 Fingerprint (md5)  
**79:c4:3f:b5: 0d:ac:a3:85:  
7d:83:fa:3b: 7f:c1:fe:5e**



ECDSA Fingerprint (md5)  
**ac:52:9a:65: cd:e0:fa:6d:  
8c:6c:d1:78: a0:93:c4:4d**

**SSH RSA Fingerprint** of the Puplic Key of the PQI-DEs for verification of the connection via the software WinPQ lite / WinPQ.

**SSH ECDSA Fingerprint** of the Puplic Key of the PQI-DEs for verification of the connec-tion via the software WinPQ lite / WinPQ. Elliptic Curve Digital Signature Algorithm (ECDSA)

## 6.4.2 Grafisches Display



Press the "right" and "left"  keys on the keypad to switch to the selection menu of the graphic display. With the keys "left", "right"  on the keypad the measured variable can be selected and with the "Enter" key it can be activated or deactivated. The "down" key on the keypad is used to switch to the bar chart. The desired harmonic can be selected with the "left", "right" keys. By pressing the "Enter" key, the measurement data of the selected harmonic is displayed below the legend. The selected harmonic is marked by a dot below the bar chart. Press the "Return"  key to exit the selection menu.

### 6.4.2.1 Bar graph harmonics

The following screen pages provide online information of the measured data in graphical form:

Display page 1

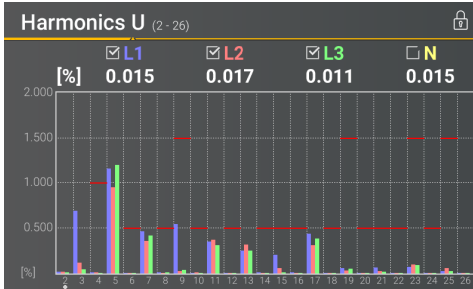

The presentation of the bar graphs depends on the selected network type:

- Net type 4-wire: Bar graphs voltage harmonics H2 - H26 for L1, L2, L3 and N.
- Net type 3-wire: Bar graphs voltage harmonics H2 - H26 for L12, L23 and L31.

The red limit lines symbolise the limit value of the respective voltage harmonics according to EN 50160.

Display page 2

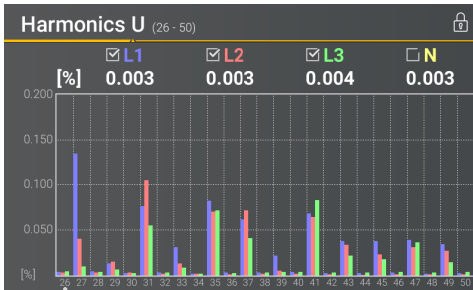

The presentation of the bar graphs depends on the selected network type:

- Net type 4-wire: Bar graphs voltage harmonics H26 – H50 for L1, L2, L3 and N.
- Net type 3-wire: Bar graphs voltage harmonics H26 – H50 for L12, L23 and L31.

The red limit lines symbolise the limit value of the respective voltage harmonics according to EN 50160.

Display page 3

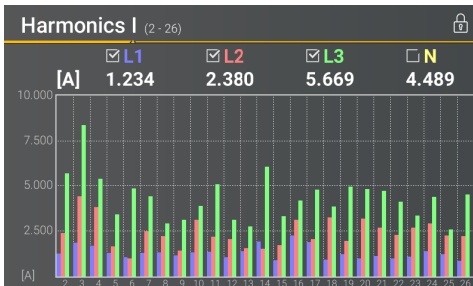

- Bar graphs current harmonics H2 - H26

### Display page 4

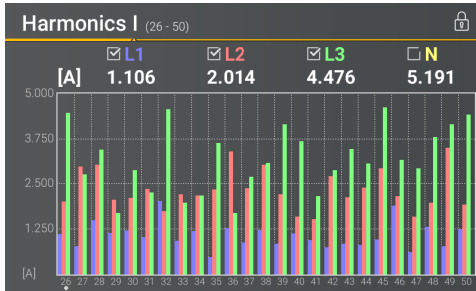

0 Bar graphs  
current harmonics H26 – H50

### Display page 5

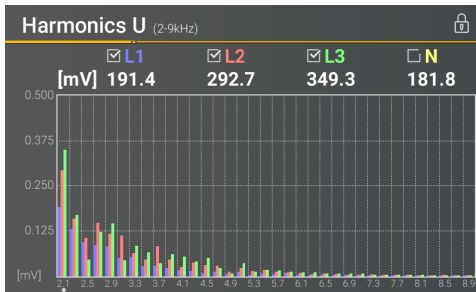

0 Bar graphs  
Voltage harmonics 2 - 9 kHz..



The bar graphs for the frequency bands 2 - 9 kHz are only displayed with device option B1.

### Display page 6

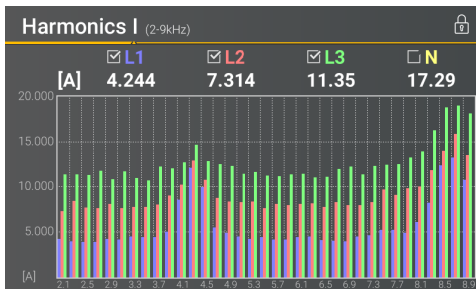

0 Bar graphs  
current harmonics 2 - 9 kHz..



The bar graphs for the frequency bands 2 - 9 kHz are only displayed with device option B1..

## 6.4.2.2 Section detailed information

Display page 1: Vector diagram

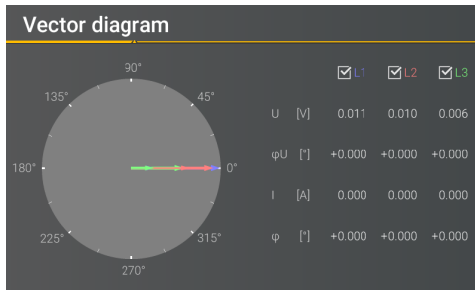

Voltage vector U1E, U2E, U3E.

Current vector I1, I2, I3

**Additionally numeric display:**

Phase angle of the respective volt-age vector

Phase shift current-voltage

Display page 2: States of binary inputs and outputs

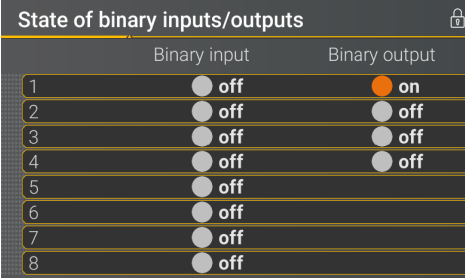

	Binary input	Binary output
1	<input type="radio"/> off	<input checked="" type="radio"/> on
2	<input type="radio"/> off	<input type="radio"/> off
3	<input type="radio"/> off	<input type="radio"/> off
4	<input type="radio"/> off	<input type="radio"/> off
5	<input type="radio"/> off	
6	<input type="radio"/> off	
7	<input type="radio"/> off	
8	<input type="radio"/> off	

State of eight binary inputs

State of four binary outputs

Display page 3: Level time diagram of residual current measurement

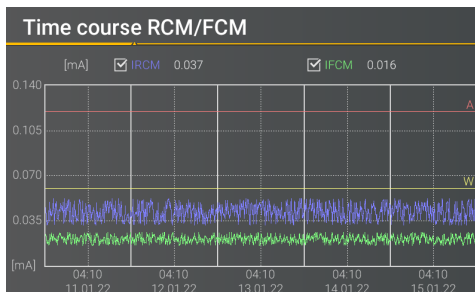

Diagram of the residual current (RCM) and fault current (FCM) over the last 7 days

**Selectable curves:**

Residual current (IRCM)

Fault current (IFCM)

**Thresholds:**

Warning threshold

Alarm threshold

### 6.4.3 Pop-up display for residual current measurement messages

According to DIN EN 62020, the task of a residual current monitor (RCM) is to monitor an electrical installation or circuit for the occurrence of a residual current and to indicate by means of an alarm if this exceeds a specified value.

In the following, the different pop-up displays implemented for the RCM function are described in this chapter.



Chapter 6.5.2, chapter 7.5.3.6 and chapter 7.5.3.8 described the parameterisation of the RCM function in detail.

#### 6.4.3.1 Pop-up Display Alarm Message

Display Pop-up Display Alarm Message

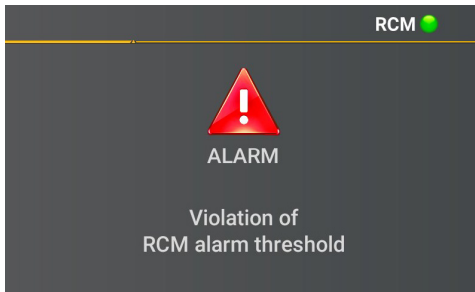

If the set alarm threshold is exceeded (see chapter 6.5.2), a visual alarm message must appear on the display according to DIN EN 62020.



In addition to the visual signal, a binary output can be switched, e.g. to give an acoustic signal. Chapter 7.5.3.6 described the parameterisation of the binary output.



Press the "Enter" key  on the keypad to switch to the acknowledgement menu for the alarm message.n.

Display Acknowledgement menu for the Alarm Message

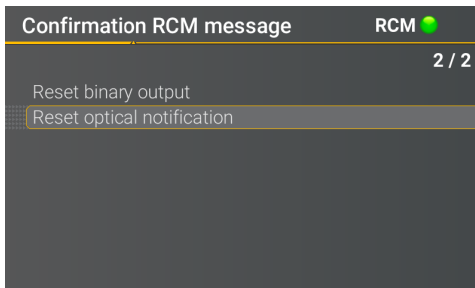

In this display, you can reset the optical message and the binary outputs.



According to DIN EN 62020, the optical signal can only be reset when the alarm threshold is no longer violated.

### 6.4.3.2 Pop-up Display Warning Message

Display Pop-up Display Warning Message



If the set warning threshold is exceeded (see chapter 6.5.2), a visual alarm message must appear on the display according to DIN EN 62020.



In addition to the visual signal, a binary output can be switched (see chapter 7.5.3.6).



Press the "Enter" key  on the keypad to switch to the acknowledgement menu for the alarm message.

Display Acknowledgement menu for the Warning Message

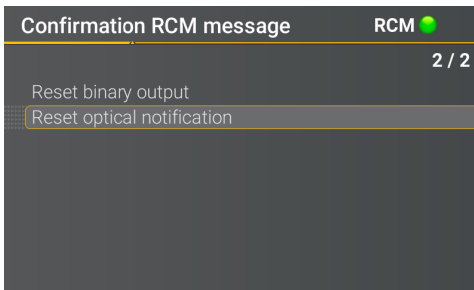

In this display, you can reset the optical message and the binary outputs.



According to DIN EN 62020, the visual signal can be reset at any time, even if the warning threshold is still violated.



The warning message can be automatically reset when the value falls below the warning threshold. Chapter 7.5.3.8 described the parameterisation required for this.

### 6.4.3.3 Pop-up Display Error Message

#### Pop-up Display Error Message

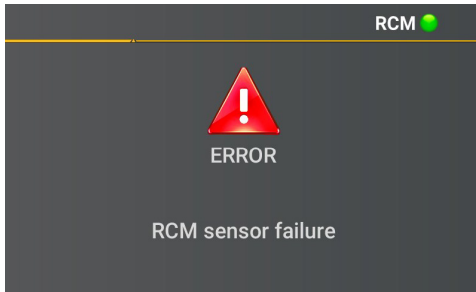

If an error occurs (e.g. wire breakage in the differential current transformer) an error message is displayed.



In addition to the visual signal, a binary output can be switched (see chapter 7.5.3.6).



Press the "Enter" key  on the keypad to switch to the acknowledgement menu for the alarm message.

#### Acknowledgement menu for the Error Message

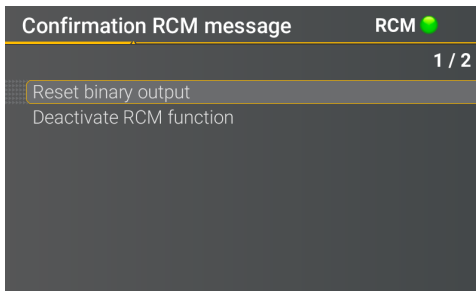

In this display, you can disable the RCM function until the error is corrected. The binary output can also be reset.





After deactivating the RCM function, the multimes F144-PQ restarts..



The error message is automatically reset when the error is corrected.

## 6.5 Setup display

Pressing the  key on the keypad will change the display to the setup menu. The following main menus are available in setup mode:

Setup	RCM 
	2 / 8
Parameters	
RCM	
Time setup	
Basic setting	
Memory	
Interface config.	
SCADA	
Display	

### 6.5.1 Parameter

#### 1 Parameter page 1

Parameters	1 / 8
Net type	4 cond., 3 phase
Net frequency [Hz]	50
Voltage transducer	1.00
Current transducer	1.00
Nominal Voltage [V]	230.0
Reference voltage [%]	100.000
Reference voltage [V]	398.37
Nominal current [A]	5.0

## 1 Net type

Entering the grid type "3-conductor grid", "4-conductor grid" and/or "4 x 1 conductor grid" will determine how the Power Quality events are recorded.

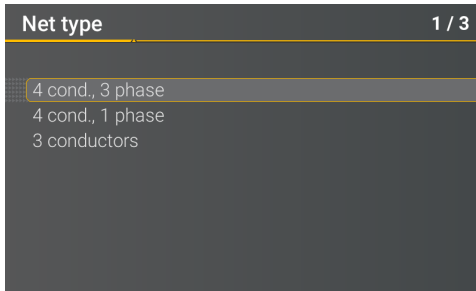

Switch between 3-conductor and 4-conductor grids.

0 In a 3-conductor grid, all events are calculated from the line-line voltages.

0 In a 4-conductor grid and/or a 4 x 1 conductor grid all Power Quality events are determined from the line-earth voltages.

## 1 Grid frequency

Setting grid frequency to 50 Hz or 60 Hz. When used in DC networks, this parameter can be ignored.

## 1 Voltage converter

Corresponds to the ratio between the primary and secondary voltage. Example: Voltage: primary = 20,000 V / secondary = 100 V; conversion factor = 200

## 1 Current transformer

Corresponds to the ratio between the primary and secondary current. Example: Current: primary = 100 A / secondary = 5 A; conversion factor = 20

## 1 Nominal Voltage / Reference Voltage

The displayed value for the nominal voltage is:

- 0 In a 4-conductor grid = 230 V line-earth voltage
- 0 In a 3-conductor grid it corresponds to the set primary value of the voltage transformer. The % value is used to set the reference voltage at a different value to the nominal voltage.



**Example 1:** 20,000 V \* 105% = Reference voltage of 21,000 V. This is the reference value for all trigger thresholds as well as Power Quality events.

**Example 2:** 500 V grid (line-line): 230 V \* 125% = 287.5 V (line-earth)

## 1 Nominal Current

The nominal current corresponds to the set system current from the commissioning wizard (see chapter 6.3).

## 1 Reference channel

Parameters		6 / 8
Reference channel	U1N	
Power measurement	Standard	
Flicker calc.	230V	

The reference channel defines the measurement channel for frequency measurement and grid synchronisation. All phase angles are related to this channel.

### 1 Power measurement

The power calculation in the device firmware can be selected between two measurement functions:

- 0 Power calculation according to DIN40110-Part 2 - with calculation of the unbalance reactive power.
- 0 Simplified power calculation without consideration of the unbalance reactive power in the 3-phase power (standard).



This setting affects the measured power values in the device display, the online measured values and the recorded measurement data. The unbalance reactive power plays a role if there is a large current unbalance at the measuring point.

## 6.5.2 Residual Current Measurement / RCM

The RCM function is disabled by default. By pressing the "Enter" key  the function can be activated.

RCM	
	1 / 10
State	activated
Transformer factor residual current	600.00
Selected observed current	IRCM
Rated response residual current IRN [mA]	300.00
Residual current warning threshold [mA]	150.00
Residual current alert threshold [mA]	300.00
Slope rising line [mA/kW]	100
Maximum threshold current [mA]	600.00



When the RCM function is activated, the long-term recording and the fault record in case of overcurrent of the residual current are also activated automatically (see chapter 7.5.3.6 and chapter 7.5.4).

RCM	
	9 / 10
RCM state change delay [s]	3
Acknowledge all binary output	

### 1 Transformer Factor Diff.Current

Parameterisation of the transformer factor of the installed differential current transformer. When using the residual current transformer with part number 111.7097.020, the following transformer factor residual current must be set:

**0 600**

### 1 Rated response differential current [A]

Setting of the rated response differential current at which the RCM must respond under specified conditions. According to DIN EN 62020, preferred values of the rated response differential current are:

**0 0,006 – 0,01 – 0,03 – 0,1 – 0,3 – 0,5 A**

### 1 Selection of monitored current

Selection of whether the residual current (IRCM) or the fault current (IFCM) is to be monitored.

### 1 Diff. current warning threshold [mA]

Definition of the warning threshold

### 1 Diff. current alarm threshold [mA]

Definition of the alarm threshold

### 1 Slope gradient [mA/kW]

Optional definition of a coefficient for a linear slope of the thresholds. A detailed explanation can be found in chapter 7.4.9

### 1 Maximum threshold current [mA]

Specification of the maximum threshold current when using the linear rise curve.

### 1 Time delay RCM state change [s]

Setting a time delay between the RCM state changes.

### 1 Acknowledge all binary outputs

Reset all binary outputs to the initial state.



The multimes F144-PQ restarted after activating the RCM function. The residual current measurement starts automatically after the restart.

This can be seen from the visualisation  in the unit display.

The parameterisation for residual current measurement with the WinPQlite is described in chapter 7.4.9.

### 6.5.3 Time settings

The multimes F144-PQ has a variety of options for synchronising the time in the device to the world clock. KBR recommends selecting a high-precision time synchronisation variant in each case and also taking into account the quality of the time signal..

#### 6.5.3.1 Time settings DCF77

The measuring device can obtain the time via an external DCF77 clock (Germany / Austria restricted / Switzerland restricted). The following settings must be made in the menu.

Time setup		1 / 5
Time protocol advanced	DCF77	
Time zone intern	+01:00	
DST	INT	
DST change		
Date	15.08.19	
Time	15:16:04	

Set the time protocol of the multimes F144-PQ to an external DCF77 radio-controlled clock.

DCF setup		1 / 2
Interface type	RS232	
Timezone extern	+00:00	

Set the interface type to RS232/RS485 and the time zone of the external DCF signal.

### 6.5.3.2 Connection DCF77 radio clock

It is recommended to use the COM2 interface as a time synchronisation interface. synchronisation interface. The following wiring is required to connect the DCF clock to the multimes F144-PQ wiring is necessary:

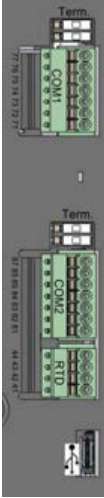
picture	COM	clamp	function	DCF Clock Wires Description
	COM 1 (X7)	77	RS485 Pos (A)	
		76	RS485 Neg (B)	
		75	CTS	
		74	RxD	
		73	GND	
		72	RTS	
		71	TxD	
	COM 2 (X8)	87	RS485 Pos (A)	
		86	RS485 Neg (B)	
		85	CTS	
		84	RxD	green wire of DCF - clock = clock signal
		83	GND	white wire of the DCF - clock = GND
		82	RTS	red wire of the DCF - clock = +6V
		81	TxD	black wire of the DCF - clock = -6V

- 0 Parameterise interface type to RS232
- 0 External time zone: +1 -as DCF signal with local time (Frankfurt) is received
- 0 Internal time zone: +1 -so that the device shows the time correctly on the display internally (local time)

### 6.5.3.3 Manual time setting

Time setup		1 / 6
Time protocol	Manual	
Timezone intern	+01:00	
DST	INT	
DST change		
Date	15.08.19	
Time	15:17:05	

**0 Time protocol:**  
**Manual:** The time is set manually on the device.

**0 Internal time zone:**  
 Definition of the time zone in which the device is located

**0 DST**

**INT:** The summer/winter time setting is determined internally by the device

**OFF:** Summer / winter time setting is switched off

**0 Date:** Enter the local date

**0 Time:** Enter the current local time



The multimes F144-PQ internally converts the times into the UTC format using the times entered and the time zones entered. All stored measured values are in UTC. It is therefore recommended to enter the time zones correctly!

### 6.5.3.4 Summer/winter time changeover (DST - Daylight Saving Time)

If the summer time operating mode is set to internal, the summer/winter time changeover in the multimes F144-PQ takes place automatically every year. The multimes F144-PQ uses an internal algorithm with the following three parameters:

DST change		6 / 6
Winter to summer		
Date	25.03.	
Time	02:00	
Day of week	Sunday	
Summer to winter		
Date	25.10.	
Time	03:00	
Day of week	Sunday	

Menu for setting the parameters for summer time changes.

**0 Day and month:** This is not specifically the date/month of the next change, but rather a method to specify the week in the month that the change is to occur on. Refer to the following examples.

**0 Weekday:** The day of the week that the changeover always takes place on.

**0 Time:** Time that the changeover will occur (the start of the changeover).

## 1 Example 1: Europe – Germany

The changeover from summer to wintertime always takes place on the last Sunday in the month of Octo-ber at 03:00 with the time changing back to 02:00 hrs.

The changeover from winter to summertime always takes place on the last Sunday in March at 02:00 with the time changing forward to 03:00 hrs.

	Summer to wintertime	Winter to summertime
Date and Month	25.10	25.03
Day	Sunday	Sunday
Time	03:00.	02:00.

The following algorithm is executed in the multimes F144-PQ with these parameters:

Changeover from daylight saving time at 3 a.m. on the Sunday occurring on or after 25 October. I.e. the first Sunday on or after the 25th of the month. As there are 31 days in October, the Sunday that falls on or after the 25th is always the last Sunday of October.

Changeover to summer time at 2 a.m. on the Sunday that falls on or after 25 March. I.e. the last sunny day of the month of March.

## 1 Example 2: Australia – New South Wales

The changeover from summer to winter time takes place on the first Sunday in April at 03:00 with a time shift back to 02:00.

The changeover from winter to summer time always takes place on the first Sunday in October at 2:00 a.m. with a time shift forward to 03:00 a.m.

	Summer to wintertime	Winter to summertime
Date and Month	01.04	01.10
Day	Sunday	Sunday
Time	03:00.	02:00.

These parameters ensure for all future years that the changeover from summer to winter time is always carried out automatically by the multimes F144-PQ on the first Sunday on or after 1 April and the changeover from winter to summer time is always carried out automatically on the first Sunday on or after 1 October.

### 6.5.3.5 NTP time setting

The multimes F144-PQ has the possibility to synchronize itself with the Network Time Protocol (NTP) to an existing NTP server in the network. The used NTP server should be able to deliver a high time signal quality.

Synchronization to SNTP server is possible, but not recommended due to high inaccuracies.

Time setup		1 / 5
Time protocol advanced	NTP	
Timezone intern	+01:00	
DST	INT	
DST change		
Date	15.08.19	
Time	15:19:26	

**Time protocol::**

**0 NTP:**  
 The time is set via an NTP server available in the network  
 The NTP servers can be entered by clicking on "extended"  
 The multimes F144-PQ supports up to four time servers in the network. The device automatically uses the NTP server with the highest accuracy.

NTP setup		1 / 8
Time server 1 IP	0.0.0.0	
Time server 1 Port	123	
Time server 2 IP	0.0.0.0	
Time server 2 Port	123	
Time server 3 IP	0.0.0.0	
Time server 3 Port	123	
Time server 4 IP	0.0.0.0	
Time server 4 Port	123	

**0 Time server 1 IP:**  
 Enter the IP address of the time server  
**0 Time server 1 Port:**  
 Enter the network port under which the device can reach the NTP server

 The port for the NTP server is, by default, "123" NTP and must be accessible from the device to the NTP server.

 It is recommended to use an NTP server with a stratum of at least 8. All NTP servers with a higher stratum are ignored by the device.  
 See also: [https://de.wikipedia.org/wiki/Network\\_Time\\_Protocol](https://de.wikipedia.org/wiki/Network_Time_Protocol)

### 6.5.3.6 NMEA-ZDA time setting

**Time setup**
1 / 5

Time protocol	NMEA:ZDA
advanced	
Timezone intern	+01:00
DST	INT
DST change	
Date	15.08.19
Time	15:20:28

**NMEA setup**
1 / 2

NMEA protocol	RS232
PCM protocol	RS232

Setting up the RS232/RS485 interface for NMEA protocol

### 6.5.3.7 NMEA-RMC time setting

**Time setup**
1 / 5

Time protocol	NMEA:RMC
advanced	
Timezone intern	+01:00
DST	INT
DST change	
Date	15.08.19
Time	15:21:14

**NMEA-Einstellungen**
1 / 2

NMEA-Protokoll	RS232
PCM-Protokoll	RS232

Setting up the RS232/RS485 interface for NMEA protocol

### 6.5.3.8 IRIG-B time setting

Time codes between instrument groups, commonly known as IRIG time codes, are standard formats for the transmission of time information. Atomic frequency standards and GPS receivers, which are designed for precise timing, are often equipped with an IRIG output.

With the COM2 interface, the multimess F144-PQ has the option of using the precise IRIG B format for time synchronisation.

The correct format IRIG-BXX0..3 or IRIG-Bxx4-7 must be selected on the multimess F144-PQ and the time zone of the synchronised time must be specified so that the multimess F144-PQ can save the measurement data internally with a correct UTC time stamp. The IRIG-BXX0..3 format does not provide any information on the current year; in this case, the multimess F144-PQ adopts the year of the last manual time setting.

#### IRIG-Bformats 0 to 3

Time setup		1 / 5
Time protocol advanced	IRIG-Bxx0..3	
Timezone intern DST	+01:00	
DST change	INT	
Date	15.08.19	
Time	15:22:36	

IRIGB setup		1 / 2
Interface type	RS232	
Timezone extern	+00:00	

#### IRIG-B formats 4 to 77

Time setup		1 / 5
Time protocol advanced	IRIG-Bxx4..7	
Timezone intern DST	+01:00	
DST change	INT	
Date	15.08.19	
Time	15:23:17	

IRIGB setup		1 / 2
Interface type	RS232	
Timezone extern	+00:00	

- 0 Selection of the IRIG-B format
- 0 Setting up the COM 2 interface and time zone sent from the external IRIG B clockd

### 6.5.3.9 IEEE 1344 time setting

IEEE 1344 is a standard that defines parameters for synchrophasors for energy systems. The standard extension of the IRIG-B time code includes year, time quality, daylight saving time, local time offset and leap second information.

In addition to the IEEE1344 protocol, the interface must also be selected on the multimes F144-PQ and the time zone of the synchronised time must be specified so that the multimes F144-PQ can save the measurement data internally with a correct UTC time stamp.

Time setup		1 / 5
Time protocol	IEEE1344	
advanced		
Timezone intern	+01:00	
DST	INT	
DST change		
Date	15.08.19	
Time	15:23:48	

Time synchronization to an IRIG-B time proto-col (in accordance with IEEE1344))

IEEE1344 setup		1 / 2
Interface type	RS232	
Timezone extern	+00:00	

Setting up the interface and the time zone

## 6.5.4 Basic setting

Basic setting		1 / 8
Language	English	
Wizard		
Menu password	0000	
Lock menu		
Drag indicator	10min	
Reset events		
Reset energy counter		
Reset I <sub>max</sub>		

### 0 Language:

Select the display language

### 0 Automatic setup:

This function guides you through an automated device setup. This function is started automatically during initial commissioning and is not called up again afterwards. With "Autom. setup", the guided commissioning can be carried out again at any time.



All data saved on the measuring device is deleted when the automatic setup is executed. In addition, the entire parameterisation except for the changes you have made in the wizard is reset to the factory settings.

### 0 Menu password:

Access to the device setup can be blocked via a 4-digit password (description see chapter 6.5.4).

### 0 Lock menu:

Use this function to lock the menu

### 0 Trailing indicator:

Selection of the data class for the extreme values of voltage. The following data classes can be selected:

- 0 10/12 periods (200ms interval)
- 0 second interval
- 0 10 minutes interval
- 0 N minutes interval



Die Extremwerte für Strom und Spannung werden bei Auswahl einer anderen Datenklasse automatisch zurückgesetzt!

0 **Reset events:** The event counter for fault records and PQ events in the device display is reset to 0. All measurement data and PQ events in the device memory are retained.

0 **Reset energy counters:** The energy counters in the device display and in the device memory are set to 0.

0 **Reset Extrema:** The absolute maximum value (voltage and current) can be reset here.

## 6.5.5 Password lock device display

Access to the device setup can be disabled via a 4-digit password..

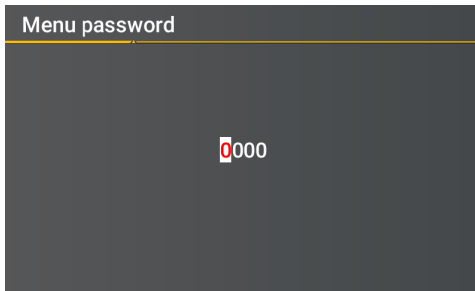

If a password is assigned, no access to the device set-up via the display is possible..

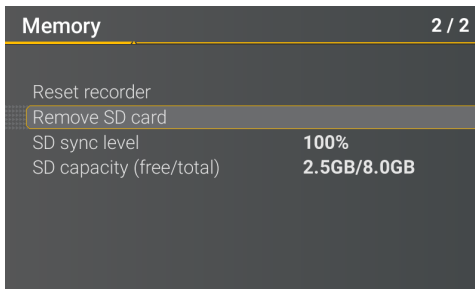

- 0 Enter your correct password
- 0 Confirm with unlock



Now the device setup over the keys and the display can be achieved. The password has no restriction for the software.

## 6.5.6 Memory management

The "Remove SD card" function stops the copying function for the measuring data of the internal memory to the SD memory card and releases the card for removal.

Memory		2 / 2
Reset recorder		
Remove SD card		
SD sync level	100%	
SD capacity (free/total)	2.5GB/8.0GB	

## 6.5.7 Setting up the device interfaces

The multimes F144-PQ has a TCP/IP interface for communication with the WinPQ Lite or WinPQ client software. The necessary parameters can be set in the Interfaces menu.

Interface config.		1 / 4
DHCP	deactivated	
IP address	172.16.3.1	
Subnet mask	255.255.0.0	
Gateway	192.168.0.1	



The multimes F144-PQ is delivered factory setting with the IP address 192.168.56.95 and the subnet mask 255.255.0.0 is delivered.

### 0 DHCP

Activate or deactivate DHCP:

**0 DHCP deactivated:** The measuring device is used with a permanently assigned IP address. The assignment of the IP address is explained in the next step.

**0 DHCP activated:** The measuring device receives its IP address via an existing DHCP server in the network.

### 1 IP address / subnet mask / gateway

Enter a free IP address and the corresponding subnet mask and gateway. Please ensure that you use IP addresses that in the same subnet as your PC if you want to communicate with the device directly on site.

## 6.5.8 Display

The display behavior of the PQI-DE can be adjusted in the Display menu.

Display		1 / 4
Brightness [%]	70	
Standby timeout [s]	900	
Standby brightness [%]	10	
Screensaver	deactivated	



The multimes F144-PQ s delivered in the factory setting with the display brightness of 70%, a standby timeout of 900 seconds and the standby brightness in standby of 10%.

### 1 Brightness [%]

The display brightness can be adjusted in 1-percent steps from 10 % to 100 %.

### 1 Standby brightness [%]

Adjustment of the standby brightness in 1 percent steps from 0 % to 70 % possible.

### 1 Standby timeout [s]

Standby timeout can be set in 1-second increments from 60 seconds to 9999 seconds. After the standby time has elapsed, the set brightness in the display becomes active.



### 1 Screensaver

Enable or disable screensaver.



The standby mode can be left by pressing any key.

## 6.6 Display lock



The device display of the multimes F144-PQ can be completely locked by pressing the key combination „Return“  and „Home“  five seconds`



When the lock is activated, the display of the device is switched off completely. It is no longer possible to view the display or the setup display.

When any device key is pressed, the following message is displayed:



To unlock the display, press the key combination "Return"  and „Home“  again for five seconds.

## 7 Modbus

The following data classes are available in the PQI-DA smart via Modbus TCP or Modbus RTU:

Data class	Measurand	Functioncode
10 ms	All measurands	Read Holding Register
200 ms	All measurands	Read Holding Register
1 sec	All measurands	Read Holding Register
3 sec	All measurands	Read Holding Register
N sec	All measurands	Read Holding Register
10 min	Alle Messwerte	Read Holding Register
N min	All measurands	Read Holding Register
2 h	All measurands	Read Holding Register

The available measurands of each data class are shown in the technical datasheet of the device.

Additionally these events can be requested via Modbus::

Event	functioncode
Messages (states of 2 binary in- and -outputs, trigger command, 32 supervision states)	Read Coils
Endless counter for disturbance recorder and PQ-Events	Read Coils
Power Quality settings – write Modbus, only in contact with the support	

### 7.1 Modbus Datenpunktliste

Über Modbus stehen über 10.000 Messwerte des multimess F144-PQ zur Verfügung. Auf Anfrage erhalten Sie die Datenpunktliste von unserem Support auch als Excel-Tabelle.

### 7.1.1 Modbus settings

Settings of the Modbus TCP and Modbus RTU interface can be changed via the device setup.

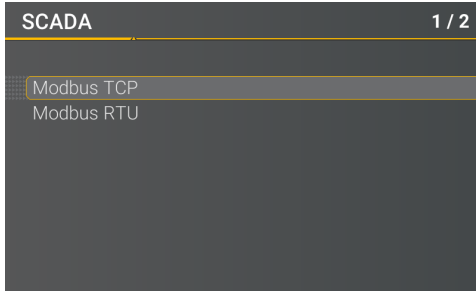

### 7.1.2 Modbus RTU

Settings for the Modbus TCP and Modbus RTU interfaces can be changed via the device setup.

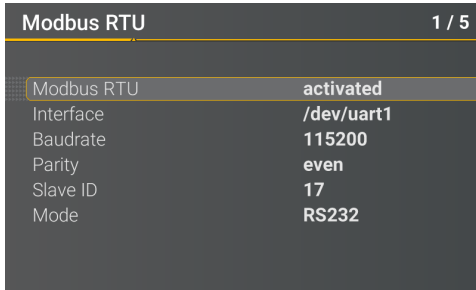

### 7.1.3 Modbus TCP

Modbus TCP is deactivated on delivery and can be activated here. The port can be parameterised. A maximum of one client may connect to the TCP server.

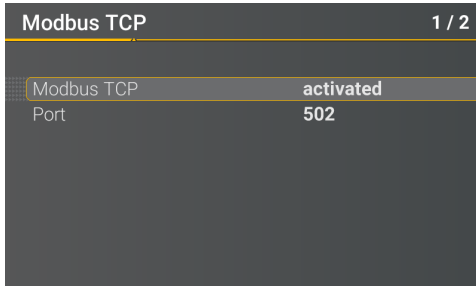

## 7.1.4 Set-up parameter Modbus with WinPQ

WinPQ Interface (CCCI)	Parameter Name	Value	Default Value
SSH	TCP Server activated	✓	<input type="checkbox"/>
Device designation	RTU Server activated	<input type="checkbox"/>	<input type="checkbox"/>
IP-Settings	Use Modbus Gateway (own ID=250)	<input type="checkbox"/>	<input type="checkbox"/>
▶ License Manager	Modbus Gateway Slave Timeout [ms]	1000	1000
Modbus	TCP Port	502	502
▶ Thresholds / Recording	TCP endianness	Little-Endian	▼ Little-Endian
▶ Binary Recording	Serial Interface	COM 1	▼ COM 1
SCADA-Manager	RTU Slave ID	17	17
Syslog	RTU endianness	Little-Endian	▼ Little-Endian
▶ Time settings	Baud rate	115200	▼ 115200
▶ User Management	Parity	None	▼ Even
	Interface mode	RS232	▼ RS232

The WinPQ lite software can be used to change the settings of the Modbus TCP and Modbus RTU interfaces can be changed. Activation takes place via the TCP or RTU server activated parameter (0 = OFF / 1 = ON).

### 0 Parameter serial:

TCP server activated	Activation of Modbus TCP
COM interface	Selection of the COM interface used (COM1 / COM2)
Baud rate	Baud rate of the serial interface for Modbus RTU
Parity	Parity of the serial interface for Modbus RTU
Interface mode	Switching between RS232 and RS 485
RTU byte order	See chapter 7.1.6

### 0 Parameter TCP/IP:

TCP port Changing the TCP/IP port for Modbus TCP/IP  
 TCP byte order See chapter 7.1.6

### 0 Parameter Modbus Gateway:

TCP server activated	Activation of Modbus TCP
Use Modbus Gateway	Activation of Modbus Gateway
TCP port	Change the TCP / IP port for Modbus TCP / IP
TCP byte order	See chapter 7.1.6
COM interface	Selection of the COM interface used (COM1 / COM2)
Baud rate	Baud rate of the serial interface for Modbus RTU
Parity	Parity of the serial interface for Modbus RTU
Interface mode S	witching between RS232 and RS 485
RTU byte order	See chapter 7.1.6

### 7.1.5 Byte Order

According to the Modbus specification, data are transmitted in the byte order Big-Endian. Regarding a 16-bit Modbus register, the data on the client side is interpreted without conversion. The following example illustrates this with the example value 0x1A2B:

Address	Communication (Big-Endian)	Client-Side (Big-Endian)
High Byte	0x1A	0x1A
Low Byte	0x2B	0x2B

### 7.1.6 Modbus-Register-Order

Interpreting the data transferred via multiple Modbus registers (e.g., 32 bits Unsigned Integer => 2 x 16 Bit Modbus registers), a distinction must be made between the Little-Endian and Big-Endian sequences. In this case, the entire register contents and not the bytes are exchanged. In the default configuration, the soft-ware is operated in Little-Endian mode. The following examples illustrate the variants:

#### 0 32 Bit-value 0x1A2B3C4D - Modus Little-Endian:

Adress	Example (Big-Endian)	Communication (Little-Endian)	Client-Side (Big-Endian)
Register 0 High Byte	0x1A	0x3C	0x1A
Register 0 Low Byte	0x2B	0x4D	0x2B
Register 1 High Byte	0x3C	0x1A	0x3C
Register 1 Low Byte	0x4D	0x2B	0x4D

#### 0 32 Bit-Wert 0x1A2B3C4D - Mode Big-Endian:

Adress	Example (Big-Endian)	Communication (Little-Endian)	Client-Side (Big-Endian)
Register 0 High Byte	0x1A	0x1A	0x1A
Register 0 Low Byte	0x2B	0x2B	0x2B
Register 1 High Byte	0x3C	0x3C	0x3C
Register 1 Low Byte	0x4D	0x4D	0x4D

### 7.1.7 Data bits

By default, a Modbus package with 8 data bits and one stop bit is set up on the measuring device.

### 7.1.8 Data types

The Modbus implementation in the multimes F144-PQ currently works with the following data type..

#### 1 Unsigned integer 32 bit (uint32\_t)

This data type stores unsigned integer values. They are stored in two registers according to the width of 32 bits.

#### 1 Float 32 bit (float32)

Floating point numbers of type Float 32 Bit are transmitted in accordance with the IEEE 754 standard. These are stored in two registers. The interpretation of the values is described in detail at [https://de.wikipedia.org/wiki/IEEE\\_754](https://de.wikipedia.org/wiki/IEEE_754).

#### 1 Float 64 bit (double)

Floating point numbers of type Float 64 Bit are also transmitted according to the standard IEEE 754 standard. The width of 64 bits requires storage in four registers. The interpretation of these values is also described at [https://de.wikipedia.org/wiki/IEEE\\_754](https://de.wikipedia.org/wiki/IEEE_754).

#### 1 Status (status\_t)

The status value has a width of 32 bits. It is stored accordingly in two registers stored accordingly. The meaning of the individual bits is listed in the following table:

Bit-Number	Meaning
0	RVC, Voltage U1E
1	Dip, Voltage U1E
2	Swell, Voltage U1E
3	Interruption, Voltage U1E
4	Overload, Voltage U1E
5	RVC, Voltage U2E
6	Dip, Voltage U2E
7	Swell, Voltage U2E
8	Interruption, Voltage U2E
9	Overload, Voltage U2E
10	RVC, Voltage U3E
11	Dip, Voltage U3E
12	Swell, Voltage U3E
13	Interruption, Voltage U3E
14	Overload, Voltage U3E
15	RVC, Voltage U12

Bit-Number	Meaning
16	Dip, Voltage U12
17	Swell, Voltage U12
18	Interruption, Voltage U12
19	Overload, Voltage U12
20	RVC, Voltage U23
21	Dip, Voltage U23
22	Swell, Voltage U23
23	Interruption, Voltage U23
24	Overload, Voltage U233
25	RVC, Voltage U31
26	Dip, Voltage U31
27	Swell, Voltage U31
28	Interruption, Voltage U31
29	Overload, Voltage U31
30	State Frequency Synchronization
31	resevated

## 1 Timestamp (uint32\_t)

The 32-bit-wide time stamp is stored in two registers and must be interpreted as an integer value without sign. This is a UNIX time stamp, that is, the number of seconds since 1 January 1970, 00:00 hours (coordinated world time UTC), with no switching counts being counted.

Example:                1478787619 (0x58248223)  
 Value of time:        11. October 2016 14:20:19 (UTC)

Further information and an implementation example can be found at [https://en.wikipedia.org/wiki/Unix\\_time](https://en.wikipedia.org/wiki/Unix_time).

## 1 Sub seconds (tmFracSec\_t)

The sub second value has a width of 32 bits and is accordingly stored in two registers. The data type is based on the time format, which is defined in IEEE C37.118. The meaning of the individual bits is listed in the following table::

Bit-Number	Meaning
0..23	Sub seconds in 100 ns increments
24..27	time quality indicator
28	Set as the announcement of a switch (1 min before)
29	Set for 24 hours after performing a leap second
30	Add (0) or remove (1) leap second
31	Indicator winter time (0) or summer time (1)

## 8. Webserver

A web server is implemented on the measuring device, which can be used to download the proprietary recording files can be downloaded from the device.

### 8.1 Parameterisation

The web server is deactivated by default and must first be activated via the parameterisation in the expert view of WinPQlite.

Communication is technically possible both unencrypted via http and encrypted via https.



Parametername	Wert	Werkseinstellung
Webserver aktivieren	<input type="checkbox"/>	<input type="checkbox"/>
Anzahl Threads	2	2
Unverschlüsselte Kommunikation (HTTP) erlauben	<input checked="" type="checkbox"/>	<input checked="" type="checkbox"/>
HTTP port	80	80
Verschlüsselte Kommunikation (HTTPS) erlauben	<input checked="" type="checkbox"/>	<input checked="" type="checkbox"/>
HTTPS port	443	443
Name des SSL/TLS Zertifikats	aerberle-cert.pem	aerberle-cert.pem

### 8.2 Access and REST-API

The web server can be accessed directly by entering the IP address in the web browser:

○ Unencrypted: <http://<IP address>>

○ Encrypted: <https://<IP address>>

A landing page appears there, which refers to the listing of the recording files. These listings are dependent on the settings made.

The listings are specified as json files and can be used for the REST API to download the files.

Product support will be happy to provide a detailed description of how to use the REST API on request.

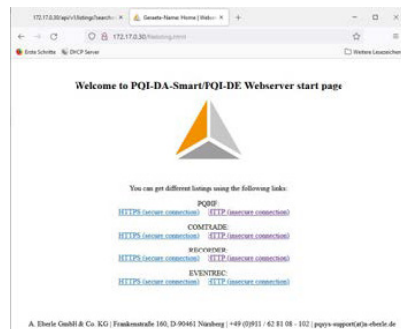

Welcome to PQI-DA-Smart/PQI-DE Webserver start page

You can get different listings using the following links:

- PQSIF: [HTTP \(<secure connection>\)](http://<IP address>) / [HTTPS \(<secure connection>\)](https://<IP address>)
- COMLADE: [HTTP \(<secure connection>\)](http://<IP address>) / [HTTPS \(<secure connection>\)](https://<IP address>)
- RECORDER: [HTTP \(<secure connection>\)](http://<IP address>) / [HTTPS \(<secure connection>\)](https://<IP address>)
- EVENTREC: [HTTP \(<secure connection>\)](http://<IP address>) / [HTTPS \(<secure connection>\)](https://<IP address>)

A. Eberle GmbH & Co. KG | Frankenstraße 160, D 90461 Nürnberg | +49 (0)911 / 42 81 08 - 102 | pqys-support@ata-electric.de

## 9. Measurement data – Measurement methods multimess F144-PQ

The aggregation of the measurement values is carried out in accordance with the IEC61000-4-30 (2008) standard for class A devices.

### 1 RMS values of the voltages and currents, min. / max. values

$$U_{\text{eff}} / I_{\text{eff}}$$

The interval value of the voltage or current is the mean of the RMS values of the length of the selected interval.

$$U_{\text{min. / max.}}; I_{\text{min. / max.}}$$

Per measurement period, the highest and lowest 10 ms voltage or current RMS value is saved in addition to the average.

### 1 Ripple control signal

U Ripple Control (200 ms)

In the multimess F144-PQ setup any interharmonic can be set. This is displayed as the 200 ms maximum value within a measurement interval..

### 1 Flicker levels $P_{\text{st}}$ / $P_{\text{lt}}$

The Short term flicker levels  $P_{\text{st}}$  (10 min) and Long term flicker levels  $P_{\text{lt}}$  (2 h) are calculated for the star and delta voltages.  $P_{\text{st}}$  and  $P_{\text{lt}}$  are defined in EN 61000-4-15: 2010.

The source for implementation recommendations is "EMV Messung von Spannungsschwankungen und Flickern mit dem IEC-Flickermeter" by W.Mombauer, VDE-Verlag, VDE-Schriftenreihe „Normen verständlich“, ISBN 3-8007-2525-8.

**Formula for  $P_{\text{lt}}$  calculation:**

$$P_{\text{lt}} = \sqrt[3]{\frac{1}{12} \sum_{i=1}^{12} P_{\text{st},i}^3}$$

The flicker meter can be parameterized in the device setup for the following grid configurations: 230 V / 50 Hz; 230 V / 60 Hz and 120 V /50 Hz; 120 V /60 Hz

## 1 THD – PWHD – K factor

Total harmonic content, calculated using the following formulae in accordance with IEC61000-4-7.

Calculating the THD values of the voltages and signal sampling:

- H2 up to H40 (based on EN50160)
- H2 up to H50 (based on IEC61000-x-x)

### 0 THD voltage:

$$THD_u = \frac{\sqrt{\sum_{v=2}^{40} U_v^2}}{U_1}$$

### 0 THD current in %:

$$THD_i = \frac{\sqrt{\sum_{v=2}^{40} I_v^2}}{I_1}$$

### 0 THD(A) current in Ampere:

$$THC = \sqrt{\sum_{n=2}^{40} I_n^2}$$

### 0 PWHD - Partial Weighted Harmonic Distortion

The partial weighted THD calculates the 14th to 40th harmonics.

$$PWHD = \frac{\sqrt{\sum_{n=14}^{40} n \cdot C_n^2}}{C_1}$$

### 0 PHC - Partial Odd Harmonic Current

The PHC is calculated from the odd current harmonics n = 21...39.

$$PHC = \sqrt{\sum_{n=21,23}^{39} C_n^2}$$

## 0 K-Factor

The values of the K-factors for phase currents are calculated from the corresponding RMS values  $C_n$  of the harmonics  $n = 1 \dots 40$ .

The K factor is a measure that indicates the ability of a transformer to withstand the current harmonics of a system.

Various transformer suppliers offer transformers with, for example, K factors  $K=4$ ,  $K=13$ ,  $K=20$  and  $K=30$ .

Transformers are heated more by harmonic currents than 50 Hz currents.

A transformer with a higher K-factor withstands this better and is not heated as much as a transformer with a lower K factor.

The device shows the K factor for the current. Only the K values that appear at maximum power are of in-terest. Just as with the THD of the currents in %, the value is not relevant at very low currents..

$$K = \frac{\sum_{n=1}^{40} (n \cdot C_n)^2}{\sum_{n=1}^{40} C_n^2}$$

### Harmonics / Interharmonics

The determination of the harmonics and interharmonics interval values displayed using the methods of the IEC61000-4-30 Class A standard based on 10/12 period values.

The multimess F144-PQ recognizes for all voltage and current channels, respectively, the harmonics up to the 50th ordinal. To evaluate the interharmonics, harmonic subgroups are created. 50 subgroups are recorded for all current and voltage channels.

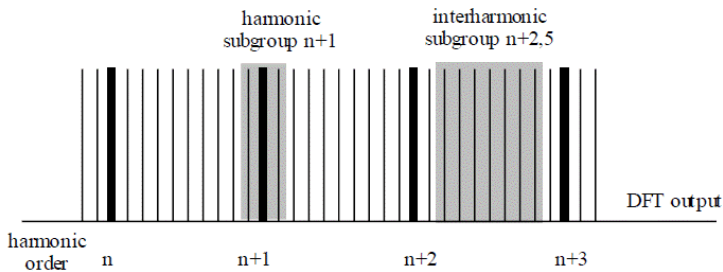

### Example:



"IH1" is the first interharmonics group and evaluated the frequency range from 5 Hz to 45 Hz.

The harmonics for  $n = 0 \dots 50$  are calculated.

Voltage harmonics (standardized, 10/12 periods):

$$U_{hn-10/12} = \frac{\sqrt{\sum_{k=n-N-1}^{n-N+1} U_{n-10/12}^2}}{U_{1-10/12}}$$

Current harmonics:

$$|I_{n-10/12}| = \sqrt{\frac{1}{2} \cdot \sum_{k=n-N-1}^{n-N+1} |C_k|^2}$$

### 1 Reactive power / Reactive energy

In the setup of the device two variants of the power calculation are adjustable

### 0 Simplified power calculation

Reactive power without unbalanced reactive power calculation:

$$Q = \sqrt{Q_V^2 + D^2} \quad Q_{\Sigma} = Q_{L1} + Q_{L2} + Q_{L3}$$

### 1 Reactive power calculation according DIN40110 part 2

Reactive power calculation with unbalanced power:

$$Q_{L-10/12} = \text{Sgn}(\varphi_{L-10/12}) \cdot \sqrt{S_{L-10/12}^2 - P_{L-10/12}^2}$$

$$Q_{10/12} = \text{Sgn}(\varphi_{1-10/12}) \cdot \sqrt{S_{10/12}^2 - P_{10/12}^2}$$

### 1 Reactive energy::

"Supply reactive energy" inductive reactive energies +EQ.

$$Q_S(n) = |Q_{L-10/12}(n)| \quad \text{für: } Q_{L-10/12}(n) \geq 0$$

$$Q_S(n) = 0 \quad \text{für: } Q_{L-10/12}(n) < 0$$

"Consumer reactive energy" capacitive reactive energies -EQ.

$$Q_S(n) = |Q_{L-10/12}(n)| \quad \text{für: } Q_{L-10/12}(n) < 0$$

## 1 Distortion reactive power - D

The distortion-reactive power - also called harmonic oscillation power - describes a special form of reactive power caused by alternating and three-phase current through nonlinear loads such as rectifiers in power supplies. The harmonics of the current in combination with the mains voltage give reactive power components, which are referred to as distortion-blocking powers.

The distortion reactive powers are calculated from the voltages and the associated distortion currents calculated:

$$D = U \cdot \sqrt{\sum_{v=2}^{\infty} I_v^2}$$

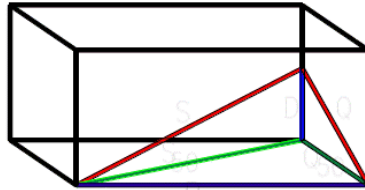

## 1 Power Factor PF

In electrical engineering the power factor or active power factor is calculated as the ratio of real power P to the apparent power S. The power factor can be between 0 and 1.

– The ration is expressed in the following equation:

– Power Factor PF:  $\lambda = P / S$

## 1 Apparent power - S

Two variants of the power calculation can be set in the multimes F1447-PQ setup

### 0 Simplified power calculation

Apparent mains power without unbalance component:

$$S = \sqrt{P^2 + Q^2}$$

### 0 Apparent grid power incl. grid unbalance according to DIN 40110 Part 2

Strang-Scheinleistungen 4-Leiter-System:

$$S_L = U_{LNrms} \cdot I_{Lrms}$$

Apparent line power 4-wire system:

$$S_L = U_{L0rms} \cdot I_{Lrms}$$

Collective apparent power n. DIN 40110:

$$S_{\Sigma} = U_{\Sigma} \cdot I_{\Sigma}$$

$$U_{\Sigma} = \frac{1}{2} \cdot \sqrt{U_{12rms}^2 + U_{23rms}^2 + U_{31rms}^2 + U_{1Nrms}^2 + U_{2Nrms}^2 + U_{3Nrms}^2}$$

$$I_{\Sigma} = \sqrt{I_{1rms}^2 + I_{2rms}^2 + I_{3rms}^2 + I_{Nrms}^2}$$

$$U_{\Sigma} = \frac{1}{2} \cdot \sqrt{U_{12rms}^2 + U_{23rms}^2 + U_{31rms}^2 + U_{1Erms}^2 + U_{2Erms}^2 + U_{3Erms}^2}$$

$$I_{\Sigma} = \sqrt{I_{1rms}^2 + I_{2rms}^2 + I_{3rms}^2 + I_{Erms}^2}$$

$$S_G = 3 \cdot [ \underline{U}_{1\_PS} \cdot \underline{I}_{1\_PS}^* + \underline{U}_{1\_NS} \cdot \underline{I}_{1\_NS}^* + \underline{U}_{1\_ZS} \cdot \underline{I}_{1\_ZS}^* ]$$

## 1 Collective apparent power n. DIN 40110:

The sign of the active power corresponds to the direction of flow of the fundamental active energy (+: output, -: reference).

The values of the phase active powers are calculated from the sampled values of a synchronisation cycle. synchronisation cycle.

$$P_{L-10/12} = \frac{\sum_{n=1}^{2048} P_L(n)}{2048}$$

(200 ms values) with string index L = {1, 2, 3, E}

The 10 min values are calculated as linear mean values.

The collective active power is defined for 4-wire systems as:

$$P_{\Sigma} = P_1 + P_2 + P_3$$

The collective effective power is defined for 3-wire systems as

$$P_{\Sigma} = P_1 + P_2 + P_3 + P_E$$

Fundamental oscillation - active power (line):

$$P_G = \operatorname{Re}\{\underline{S}_G\}$$

$S_G$  = Geometric fundamental oscillation apparent power

## 1 Symmetric Components

The complex symmetrical components are calculated from the corresponding complex spectral components

of the fundamental oscillations of the phase voltages and phase currents.

Phase voltage in a 4-wire system = Phase-to-Neutral voltage

Phase voltage in a 3-wire system = Phase-to-Ground voltage

– Positive sequence::

$$\underline{U}_{1\_PS} = \frac{1}{3} \cdot (\underline{U}_{1N-1} + \underline{a} \cdot \underline{U}_{2N-1} + \underline{a}^2 \cdot \underline{U}_{3N-1})$$

$$\underline{I}_{1\_PS} = \frac{1}{3} \cdot (\underline{I}_{1-1} + \underline{a} \cdot \underline{I}_{2-1} + \underline{a}^2 \cdot \underline{I}_{3-1})$$

– Negative sequence::

$$\underline{U}_{1\_NS} = \frac{1}{3} \cdot (\underline{U}_{1N-1} + \underline{a}^2 \cdot \underline{U}_{2N-1} + \underline{a} \cdot \underline{U}_{3N-1})$$

$$\underline{I}_{1\_NS} = \frac{1}{3} \cdot (\underline{I}_{1N-1} + \underline{a}^2 \cdot \underline{I}_{2N-1} + \underline{a} \cdot \underline{I}_{3N-1})$$

– Zero sequence::

$$\underline{U}_{ZS} = \frac{1}{3} \cdot (\underline{U}_{1N-1} + \underline{U}_{2N-1} + \underline{U}_{3N-1})$$

$$\underline{I}_{ZS} = \frac{1}{3} \cdot (\underline{I}_{1N-1} + \underline{I}_{2N-1} + \underline{I}_{3N-1})$$

## 1 Unbalance

The unbalanced voltages are calculated from the corresponding values of the modal positive sequence, negative sequence and zero sequence components.

For the EN50160 (events) only the voltage unbalance  $u_u$  is relevant and corresponds to the ratio of the negative sequence to the positive sequence. The value is expressed in [%].

### 1 Frequency analysis 2 kHz to 20 kHz

In the frequency analysis 2 kHz to 20 kHz respectively 200 Hz frequency bands are summarized.

The specification of each frequency is the centre frequency in this 200 Hz band. In the recording files themselves the supraharmonics up to 20 kHz can be recorded. Up to 18.6 kHz the 200 Hz wide frequency bands are calculated according to IEC 61000-4-7. Above this, the attenuation of the internal filter is not as high as specified by the standard. Therefore, these measured quantities are marked with a "\*".

$$Y_b = \sqrt{\sum_{f=b-95 \text{ Hz}}^{b+100 \text{ Hz}} Y_{Cf}^2}$$

**Example:** Frequency band 8.9 kHz corresponds to all 5 Hz spectral lines from 8,805 Hz to 9,000 Hz

## 10. Service

This unit is maintenance-free for customers.

 <b>DANGER!</b>	<b>Risk of death due to electric shock!</b>
<ul style="list-style-type: none"><li>➤ Do not open the unit.</li><li>➤ Maintenance of the device must only be carried out by KBR.</li></ul>	

### ➤ For service, contact

Service address: KBR Kompensationsanlagenbau GmbH  
Am Kiefernschlag 7  
D-91126 Schwabach

### ➤ Cleaning:

Use a short, slightly damp, lint-free cloth. Make sure no liquid gets in the housing. Do not use window cleaner, household cleaners, sprays, and solvent, cleaners that contain alcohol, ammonia solutions or abra-sive cleaning agents. Please use only water for cleaning.

## 11. Disposal

KBR Kompensationsanlagenbau GmbH will dispose of the device.  
Send all components to KBR Kompensationsanlagenbau GmbH:

KBR Kompensationsanlagenbau GmbH  
Am Kiefernschlag 7  
D-91126 Schwabach

## 12. Product Warranty

We guarantee that every KBR Kompensationsanlagenbau GmbH KG product is free from material and manufacturing defects under normal use.

The detailed conditions for the warranty can be found in our General Terms and Conditions at: <https://www.kbr.de>





**KBR GmbH**

Am Kieferschlag 7  
D-91126 Schwabach

T +49 (0) 9122 6373 -0  
F +49 (0) 9122 6373 -83  
E [info@kbr.de](mailto:info@kbr.de)

[www.kbr.de](http://www.kbr.de)