

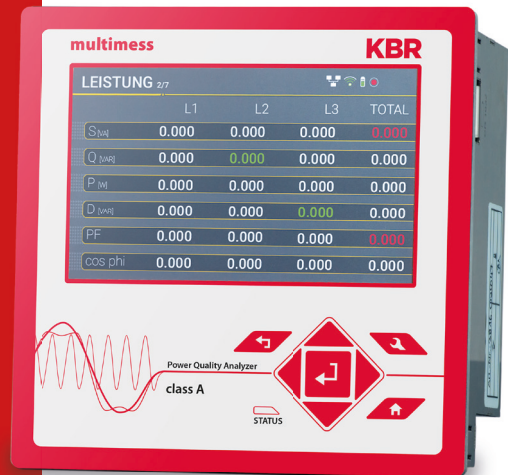

Quick guide Installation guidelines



Power Quality Analyser multimes F144-PQ

System | english



In our download centre you will find the appropriate instructions for KBR devices.
<https://www.kbr.de/en/download/operating-instructions/>

Table of contents

1.	Notes	4
1.1	General information	4
1.2	Revisions	4
1.3	Waranty	4
2.	Safety	5
2.1	Safety Instructions.....	5
2.2	Structure of the warnings.....	6
2.3	Graduation of warnings	6
2.4	Intended use	7
2.5	Other applicable	7
2.6	Target group.....	7
2.7	Cleaning.....	8
2.8	Meaning of the symbols used on the device	8
3.	Commissioning	9

KBR GmbH does not accept any liability for any loss or damage resulting from printing errors in or changes to this manual.

In addition, KBR GmbH does not accept any liability for any loss or damage caused by defective devices or devices manipulated by the user.

Copyright 2024 by KBR GmbH

Subject to change.

3.1	multimes F144-PQ Summary description.....	9
3.2	Lieferumfang.....	9
3.3	Fitting.....	10
3.4	Protection earth.....	11
3.5	Supply voltage.....	12
3.6	Mains connection for multimes F144-PQ.....	14
3.6.1	3-phase / 4-wire connection.....	15
3.6.2	3-Phase / 4-wire connection without neutral current.....	17
3.6.3	4-wire / 1-phase.....	18
3.6.4.1	Connection transformer for feature.....	19
3.6.4.2	Connection to voltage sensors.....	20
3.6.4.3	Aron / V circuit.....	21
4.	Operation of the multimes F144-PQ.....	22
4.1	Getting started.....	22
4.2	Initial Setup - Operation of the Assistant.....	22
4.3	First commissioning - wizard - procedure.....	23
4.3.1	Wizard setting Language.....	23
4.3.2	Wizard setting Power Quality standard.....	23
4.3.3	Wizard setting Net type.....	24
4.3.4	Wizard setting Net frequency.....	24
4.3.5	Wizard setting Voltage Transformer.....	25
4.3.6	Wizard setting Voltage Grid.....	25
4.3.7	Wizard setting Current Transformer.....	26
4.3.8	Wizard setting Rated Current.....	26
4.3.9	Wizard setting Date, Time and Timezone.....	27
4.3.10	Wizard setting Interface.....	28
4.3.11	Wizard setting Security Mode.....	29
4.3.13	Wizard End of commissioning.....	30
5.	Technical Data.....	31
5.1	Dimensions / Weight.....	31
5.2	Electrical safety – environmental parameter.....	31
5.3	Power supply.....	32
5.4	Voltage Inputs.....	32
5.5	Current Inputs.....	33
5.6	Binary inputs.....	33
5.7	Binary outputs.....	34
5.8	Temperature Input.....	34
5.9	Electrical safety.....	35
5.10	Connection / terminals.....	36

1. Notes

1.1 General information

These installation instructions contain all-important information for mounting and commissioning. Read the manual carefully and completely, it contains important information about the product. Observe the notes and follow the safety and warning instructions in particular. Keep the manual carefully and ensure that it is always available and can be viewed by the user of the product.

The company KBR Kompensationsanlagenbau GmbH does not accept any liability for damage or loss of any kind resulting from failure to observe the product information or resulting from printing errors or changes in this installation guidelines. The company KBR Kompensationsanlagenbau GmbH does not accept any liability for damage or loss of any kind resulting from faulty devices or from devices that have been modified by the user.

1.2 Revisions

Please note that these installation instructions may not always represent the most up-to-date information on the device. If, for example, you have changed the firmware of the device in the direction of a later firmware version, the present installation instructions may no longer be suitable in every point.

In this case, either contact us directly or use the latest version of the installation instructions available on our website (www.kbr.de) and the other documents available for the device.

Copyright 2024 KBR GmbH

Subject to change without notice

1.3 Warranty

We guarantee that every product KBR GmbH is free from material and manufacturing defects under normal use.

The detailed conditions for the warranty can be found in our general terms and conditions of business under: <https://www.kbr.de>

2. Safety

2.1 Safety Instructions

IT IS IMPORTANT FOR PERSONAL SAFETY TO FOLLOW THESE INSTRUCTIONS. THESE INSTRUCTIONS MUST BE KEPT IN A SAFE PLACE!

- Observe operating instructions.
- Always keep the operating instructions with the appliance.
- Ensure that the machine is only operated in perfect condition.
- Never open the device.
- Ensure that only qualified personnel operate the device.
- Only connect the device according to instructions.
- Ensure that the device is only operated in its original condition.
- Only operate the device with recommended accessories.
- Ensure that the device is not operated above its rated data (see technical data in chapter 5)
- Ensure that the original accessories are not operated above the rated data.
- Do not operate the device in environments where explosive gases, dust or vapours are present.

The installation instructions do not represent a complete list of all safety instructions necessary for the operation of the device. Special operating conditions may require further instructions. The installation instructions contain information that you must observe for your personal safety and to prevent damage to property.

2.2 Structure of the warnings

Warnings are structured as follows:

 SIGNAL WORD	Nature and source of the danger! Consequences if not observed. ➔ Steps to avoid the danger.
---	--

2.3 Graduation of warnings

Warnings differ according to the type of danger as follows:

 DANGER!	Warns of an imminent danger which, if not avoided, will result in death or serious injury.
---	--

 WARNING!	Warns of a potentially dangerous situation that can result in death or serious injuries when not avoided.
--	---

 CAUTION!	Warns of a potentially dangerous situation that can result in fairly serious or minor injuries when not avoided.
--	--

NOTICE!	Warns of a potentially dangerous situation that if not avoided could result in material or environmental damage.
----------------	--

	Refers to processes where there is no risk of injury or damage to property, but which must be observed for reliable operation of the device!
---	--

2.4 Intended use

The product is designed exclusively for the measurement and evaluation of voltage and current signals in the energy network. If the measuring device is used in a way which is not specified by the manufacturer, the protection supported by the device can be severely limited. The device is intended for use for measurement in the low voltage range in CAT IV (300 V) up to a maximum of 690 V (conductor/conductor). Other voltage levels such as medium- or high-voltages must be connected to the instrument via voltage transformers. All technical connection values and rated data must be observed!

The multimes F144-PQ is suitable for the following installation location and should, should only be operated in this environment.

- Mounting in a control cabinet and compact distribution board

2.5 Other applicable

For the safe and correct use of the device, please also observe the other documents such as the complete operating instructions and the additional documents supplied, as well as the relevant standards and laws.

2.6 Target group







These installation instructions are intended for trained specialist staff as well as trained and tested operating personnel. The contents of these installation instructions must be made available to the persons entrusted with the installation and operation of the system. In order to avoid damage to property and personal injury, the qualified personnel must be trained electro technically and have the following knowledge.

- Knowledge of national accident prevention regulations
- Knowledge of safety engineering standards
- Knowledge of installation, commissioning and operation

2.7 Cleaning

Use a soft, slightly moistened and lint-free towel. Make sure that no moisture penetrates the housing. Do not use window cleaners, household cleaners, sprays, solvents, cleaners containing alcohol, ammonia solutions or scouring agents for cleaning. Please use only water for cleaning.

2.8 Meaning of the symbols used on the device

	Nature and source of the danger! Read the safety instructions inside the manual!
	Functional earth of the measuring device
	USB-Interface
	TCP-IP Interface
	CE marking guarantees compliance with the European directives and regulations regarding Electromagnetic Compatibility (EMC).
	Alternating voltage (AC)
	Direct voltage (DC)

3. Commissioning

3.1 multimes F144-PQ Summary description

The Power Quality Analyser and Fault Recorder multimes F144-PQ for low, medium and high voltage networks is the central component of a system with which all measurement tasks in electrical networks can be solved.

The multimes F144-PQ can be used as a Power Quality Interface according to power quality standards such as IEC61000-2-2 / EN50160 or to check the technical connection guidelines such as DIN VDE AR 4110 and DIN VDE 4120 and many more. Due to the available SCADA interfaces such as Modbus RTU/TCP as well as IEC 61850, the device can also be used as a highly accurate measurement transducer for all physically defined measured variables in 3-phase systems parallel to the continuous recording of measured values over a very long period.

In addition to the possibility of standard evaluations, the multimes F144-PQ also has a high-speed disturbance recorder with a recording rate of 40.96 kHz/10.24 kHz and a 10ms TRMS effective value recorder. This allows a detailed evaluation of grid disturbances.

3.2 Lieferumfang

- multimes F144-PQ
- Installations guidelines
- Ethernet cable

3.3 Fitting

The multimess F144-PQ is used as a panel-mounted device and fulfils IP54 in the installed condition. Mounting must be carried out with the following cut-outs and minimum distances (see following figure). The maximum thickness of the panel for PQI-DE installation is 8mm.

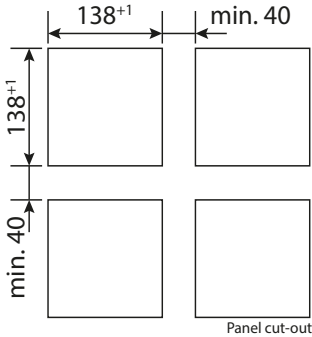

NOTICE!	Material damage due to non-observance of the installation instructions!
Non-observance of the installation instructions or incorrect installation can damage the device!	
➡ Pay attention to the audible snapping of the mounting elements	

For mounting the multimess F144-PQ, four mounting brackets are included in the scope of delivery. These must be snapped into the housing of the multimess F144-PQ at all four corners (see picture below). The clamps must then be screwed against the panel with a maximum torque of five Nm using an Allen key (2.5 mm) on the back of the PQI-DE to ensure that the PQI-DE is securely mounted in the panel cut-out.!



Mounting bracket for multimess F144-PQ



Mounting bracket engaged on multimess F144-PQ

3.4 Protection earth

The device has a protective earth, which also serves as reference potential for the voltage inputs.

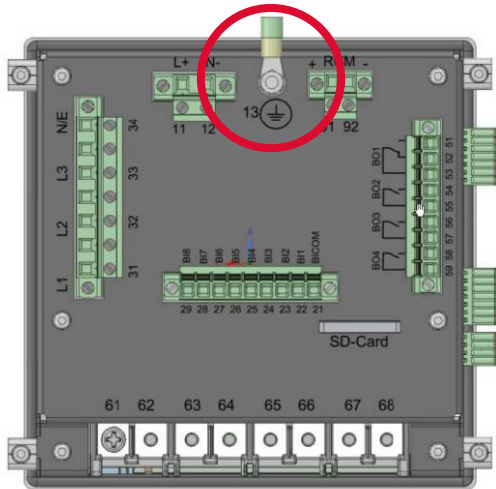

The protective earth is marked with  and terminal X1 / 13 on the measuring instrument.

Connect the earth cable to terminal X1 / 13 on the meter and tighten the screw. Use an eyelet terminal for the connection and make sure it is tight!



DANGER!

Danger to life due to electric shock!

Incorrect connection of this measuring instrument can lead to death, serious injury or fire hazard!

- The functional earth must always be connected to PE potential.
- The functional earth must not carry a dangerous voltage under any circumstance.

3.5 Supply voltage

The multimess F144-PQ is available in two different supply voltage versions. Please take the correct supply voltage from the type label before connection.

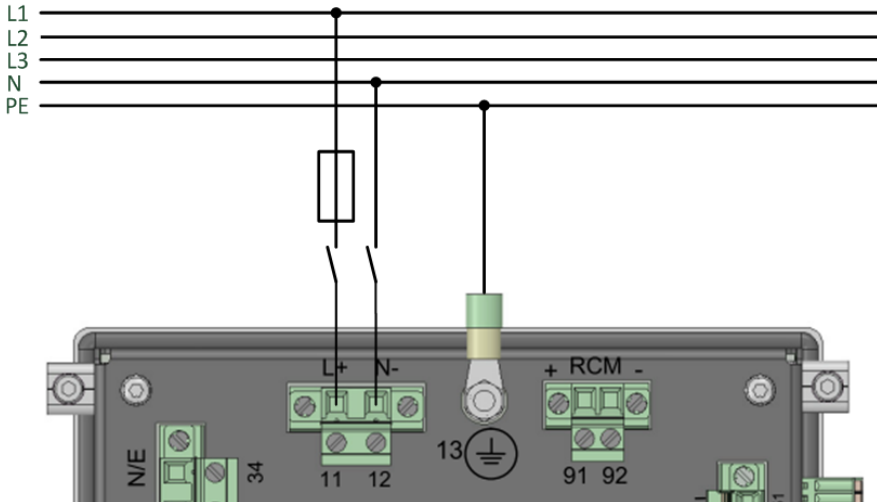

Example of connection to 230 V AC

After connecting and switching on the power supply, the status LED lights up red, changes to green and the display starts in the commissioning wizard.

 DANGER!	Danger to life due to electric shock!
<p>Serious personal injury or death may result from:</p> <ul style="list-style-type: none"> ● Touching bare or stripped wires that are energised. ● Touching dangerous inputs on the device. ➤ Make sure that the device is connected in a de-energized state. ➤ Ensure that all connecting cables are fixed and strain relief is provided. ➤ All cable requirements of the terminal blocks must be observed. (e.g. stripping length of the cables). 	

NOTICE!**Material damage due to non-observance of the connection conditions or impermissible overvoltage!**

Failure to comply with the connection conditions or exceeding the permissible voltage range may damage or destroy your device.

Before applying the supply voltage to the device, the following points must be observed:

- Voltage and frequency must correspond to the specifications on the type label!
Observe the limit values as described in the technical data!
- Observe features of the device
- In the building installation, the supply voltage must be provided by a listed miniature circuit breaker and fuse that meets the requirements of IEC 60947-1 and IEC 60947-3!
- The miniature circuit breaker must
 - be easily accessible to the user and installed close to the device.
 - Label for the respective device.
- Do not take the supply voltage at the voltage transformers.
- Provide a fuse for the neutral conductor if the neutral connection of the source is not earthed

3.6 Mains connection for multimes F144-PQ

The mains connection of the multimes F144-PQ depends on the type of mains in which the measurement is to be made.

The multimes F144-PQ is designed for direct measurement in low voltage (3 phase / 4 wire connection) for low voltage networks (TN, TT and IT networks) or for residential and industrial applications. A special form of low voltage measurement is the measurement 4-wire / 1 phase connection with which three independent voltage circuits and current circuits can be measured with the same ground conditions.

For medium and high voltage the device can be connected via suitable transformers. A connection with three voltage and current transformers is possible as well as the connection via transformer saving circuits (V-circuit, Aron circuit).

In addition, current measurements with small signal inputs are possible with the corresponding sensor transformers



WARNING!

Personal injury and damage to property due to nonobservance of the safety regulations

- ➡ Before making any connections, please read this manual thoroughly and follow the safety measures described here.

3.6.1 3-phase / 4-wire connection

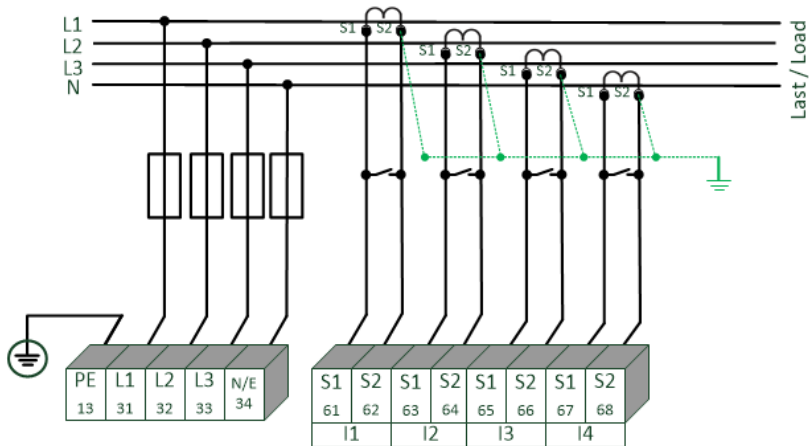

Example of a connection for a multimess F144-PQ in a three-phase four-wire system

► Voltage connections

- The voltage connections must be made as shown in the circuit diagram above
- If no N conductor connection is available, connect connections E and N together.
- Make sure that the switching mode (4-wire) is set (settings are described in chapter 4.3).

► Current connections

The multimess F144-PQ is designed for measuring circuits.

Depending on the feature, the current transformer ratio is factory-set to nominal current (e.g. 5A) and must be adapted to the transformers used. Only alternating currents can be measured, not direct currents.



DANGER!

Danger to life due to electric shock!

Attention dangerous contact voltage!

Flashover and high short-circuit currents possible in CAT III and CAT IV!

- Ensure that the PE conductor (earthing) is connected to the multimes F144-PQ.
- Before starting work, check that no voltage is present!
- Provide protective equipment for CAT II, CAT III or CAT IV.
- High-load fuses >10 kA or >50 kA must be used in accordance with the CAT.
- Short-circuit current transformers before starting work.
- Ensure that all connecting cables are fixed and strain-relieved.
- All cable requirements of the terminal blocks must be observed (e.g. stripping length of the cables)

3.6.2 3-Phase / 4-wire connection without neutral current

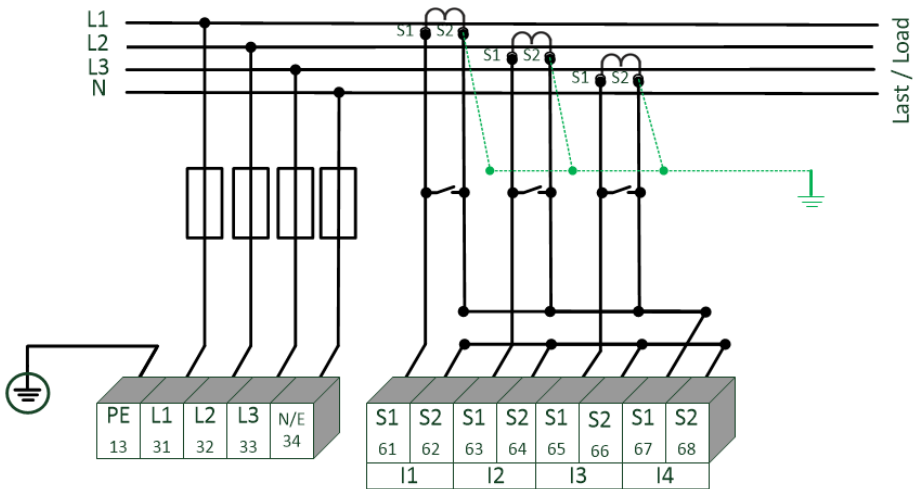

multimes F144-PQ without neutral conductor Current transformer in 4-wire connection

► Voltage connections

- If no N conductor connection is available, connect connections E and N together.
- Make sure that the switching mode (4-wire) is set (settings are described in chapter 4.3).

► Current connections

- If no neutral conductor current is available in the 3-phase / 4-wire network, the S2 current inputs of the multimes F144-PQ must all be short-circuited and the S2 terminals of the current transformers used must be connected to S1 (terminal X6:67).
- The multimes F144-PQ is designed for measuring circuits

3.6.3 4-wire / 1-phase

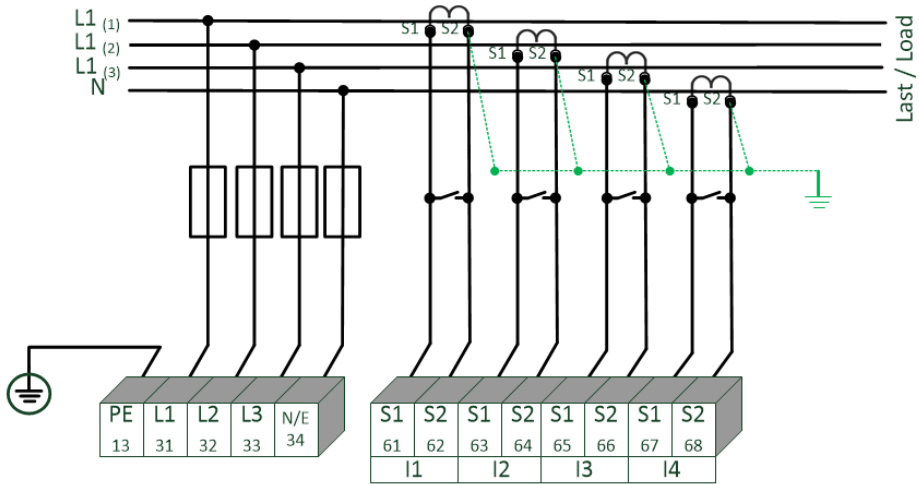

multimes F144-PQ in 4-wire connection / 1-phase

In the 4-wire network, 1-phase circuit type, no wire-conductor events and three-phase network events are evaluated. Voltages with the same earth potential can be connected (e.g. three networks with phase L1) and any currents can be connected.

! DANGER!

Danger to life due to electric shock!

Attention dangerous contact voltage!
Flashover and high short-circuit currents possible in CAT III and CAT IV!

- Ensure that the PE conductor (earthing) is connected to the multimes F144-PQ.
- Before starting work, check that no voltage is present!
- Provide protective equipment for CAT II, CAT III or CAT IV.
- High-load fuses >10 kA or >50 kA must be used in accordance with the CAT.
- Short-circuit current transformers before starting work.
- Ensure that all connecting cables are fixed and strain-relieved.
- All cable requirements of the terminal blocks must be observed (e.g. stripping length of the cables)

3.6.4 3-phase / 3-wire connection

3.6.4.1 Connection transformer for feature

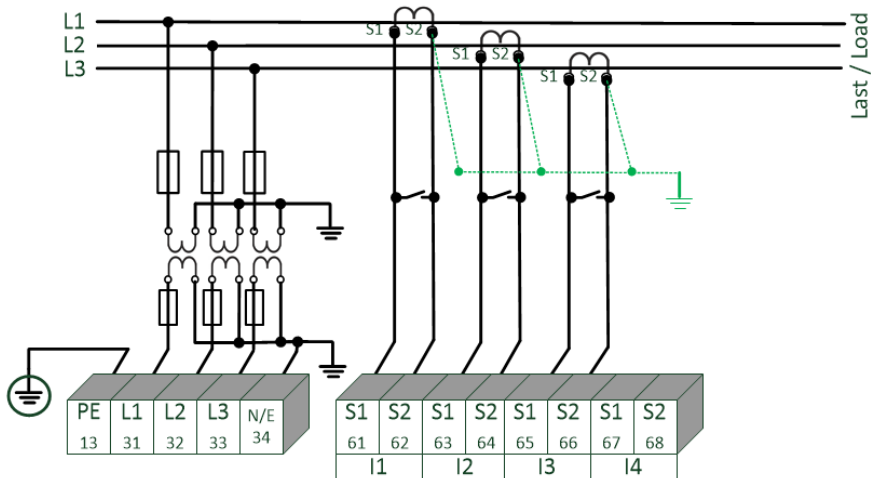

multimes F144-PQ in 3-wire connection for medium and high-voltage via transformer

► Voltage connections

- Make sure that the measuring cable N / E is connected to terminal 34 for each measurement. This is usually the earthing point of the voltage transformer.
- Ensure that the switching mode (3-wire) is set (settings are described in chapter 4.3). Set the voltage transformation ratio
- Enter the nominal voltage of the conductor-conductor voltage.

► Current connections

- Set current transformer ratio.



Connection multimes F144-PQ current IN in 3-wire network
If a current is connected to input IN in the 3-wire network, it is not physically measured. The current IN is always calculated in 3-wire operation.



transducer settings

The transducer settings are set in the assistant in the chapter „Parametrization“ (see User Manual).

3.6.4.2 Connection to voltage sensors

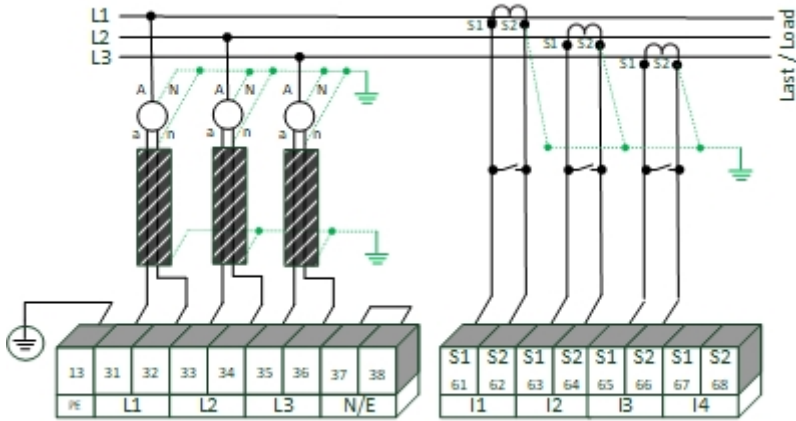

multimes F144-PQ in 3-wire connection for medium and high-voltage via voltage sensors

► Voltage connections

- Ensure that terminals 37 & 38 (N/E) are short-circuited for each measurement.
- Ensure that the shielding of the voltage sensors is grounded on both sides. Set the voltage transformation ratio.



Ground loops must be avoided! If there is a potential difference, only one side of the shielding must be grounded!

- Ensure that the switching mode (3-wire) is set (settings are described in chapter 4.3). Set the voltage transformation ratio.
- Enter the nominal voltage of the conductor-conductor voltage.

► Current connections

- Set current transformer ratio.

Connection multimes F144-PQ current I_N in 3-wire network



If a current is connected to input I_N in the 3-wire network, it is not physically measured. The current I_N is always calculated in 3-wire operation.

3.6.4.3 Aron / V circuit

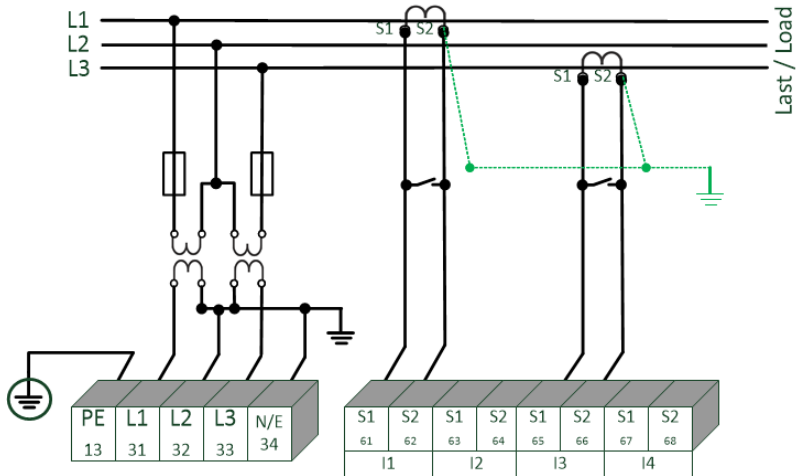

Information on the parameterization of the Aron / V circuit can be found in the user manual!



DANGER!

Danger to life due to electric shock!

Attention dangerous contact voltage!

Flashover and high short-circuit currents possible in CAT III and CAT IV!

- Ensure that the PE conductor (earthing) is connected to the multimes F144-PQ.
- Before starting work, check that no voltage is present!
- Provide protective equipment for CAT II, CAT III or CAT IV.
- High-load fuses >10 kA or >50 kA must be used in accordance with the CAT.
- Short-circuit current transformers before starting work.
- Ensure that all connecting cables are fixed and strain-relieved.
- All cable requirements of the terminal blocks must be observed (e.g. stripping length of the cables)

4. Operation of the multimes F144-PQ

4.1 Getting started

When the power analyser multimes F144-PQ is put into operation for the first time, the instrument will appear in a guided “Wizard” mode. The operator is automatically guided through the initial commissioning of the instrument. This Wizard must be performed once after the PQ meter has been fully connected.



It is recommended to perform the wizard only after all wiring has been completed so that no incorrect measurement data is recorded due to the absence of measurement voltage, currents or parameters that have not been entered.



Since firmware version 2.0 the recording of the measurement data is only started after the complete completion of the wizard!

4.2 Initial Setup - Operation of the Assistant

The following actions can be performed using the navigation cross on the multimes F144-PQ:

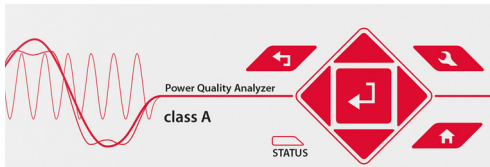

- ▶ **Arrow key right / down:** Continue in wizard
- ▶ **Arrow key left / up:** Back in wizard
- ▶ **Enter key** : Changing parameters

4.3 First commissioning - wizard - procedure

4.3.1 Wizard setting Language

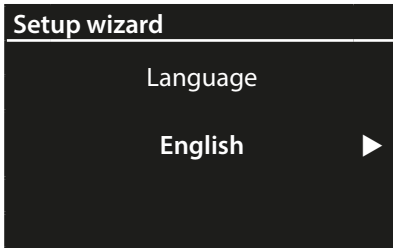

- Selection of display language

4.3.2 Wizard setting Power Quality standard



- Selection of the Power Quality standard

Press the key  to switch between the following. PQ standards

- Low-voltage grid – TN system
=> EN50160-LV
- Low-voltage grid – IT system
=> EN50160-LV-IT
- Medium-voltage grid
=> EN50160-MV
- High-voltage grid
=> EN50160-HV

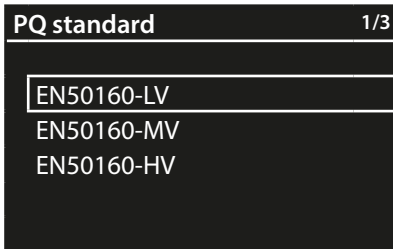

Automatic basic settings and limit values for the following voltage level according to EN50160:

The selection of the voltage level has an influence on which measures should be recorded, on the thresholds and also at the IEC61850 Interface which data can be used at IEC61850 Interface.

4.3.3 Wizard setting Net type

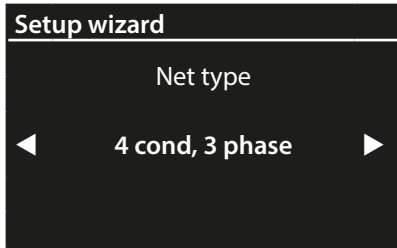

● Basic settings / network connection

	<p>The net type form cannot be edited if the PQ standard EN50160-LVIT or EN50160-MV/HV is selected!</p>
---	---

► For more information about the network connection, see Chapter Hardware connection

● Net type:

Entering the grid type „3-conductor grid“, „4-conductor grid“ and/or „4 x 1 conductor grid“ will determine how the Power Quality events are recorded.

Switch between 3-conductor and 4-conductor grids.

- In a 3-conductor grid, all events are calculated from the lineline voltages.
- In a 4-conductor grid and/or a 4 x 1 conductor grid all Power Quality events are determined from the line-earth voltages.

4.3.4 Wizard setting Net frequency



● Grid frequency

Setting grid frequency to 50 Hz or 60 Hz.

4.3.5 Wizard setting Voltage Transformer

Setup wizard

Voltage transformer
primary Voltage [V] P-P

◀ 20000.00 ▶

- **Primary Voltage:**

Corresponds to the primary rated voltage of the voltage transformer.

- **Sec. Voltage:**

Corresponds to the secondary rated voltage of the voltage transformer..

Setup wizard

Voltage transformer
sekundary Voltage [V] P-P

◀ 100.00 ▶



The voltage transformer factor is calculated automatically!



If Power Quality standard for low voltage network (EN50160-LV & EN50160-LV-IT) is selected, the page voltage transformer is skipped, because the device can cover the complete range without transformer settings. Therefore, no input is necessary, as no voltage transformer factor has to be calculated.

4.3.6 Wizard setting Voltage Grid

Setup wizard

Voltage Grid
Reference voltage [V] P-P

◀ 20000 ▶

[V] P-N 11547.01

- **Reference voltage in low voltage:**

Setting the reference voltage in the low voltage

- TN system as conductor-earth voltage in volts and in the low voltage
- ITsystem or medium and high voltage as conductor-conductor voltage in volts.



The non-editable parameters are calculated automatically.

4.3.7 Wizard setting Current Transformer



- **Primary Current:**

Primary nominal current of the connected current transformer.

- **Sec. Current:**

Secondary nominal current of the connected current transformer.

	The voltage transformer factor is calculated automatically!
---	---

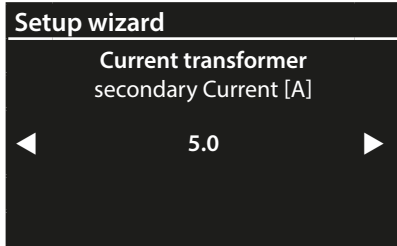

4.3.8 Wizard setting Rated Current

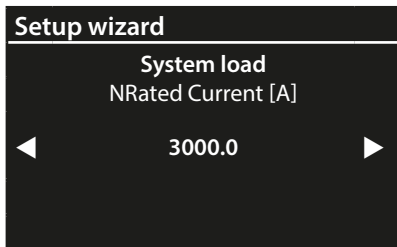

- **Anlagenstrom:**

Setting the nominal current of the system.

4.3.9 Wizard setting Date, Time and Timezone

Setup wizard

Date

◀ 14.01.24 ▶

Setup wizard

Time

◀ 11:08:10 ▶

Setup wizard

Timezone intern

◀ +01:00 ▶

Manual entry of date and time as local time. Furthermore the local time zone must be entered and if the device should calculate the changeover for summer / winter time by its own .



In the factory setting, the device is set to time zone UTC+1 with automatic winter time change-over. The time zone and summer/ winter time changeover must be adapted to local conditions. According to IEC61000-4-30, an external synchronization source such as NTP / DCF77 / GPS is required.

4.3.10 Wizard setting Interface



- **DHCP:**

DHCP deactivated: The device is used with a fixed IP address which have to be parameterized in the next step.

DHCP activated: The device gets its IP-Address direct from a DHCP Server, which has to be reachable!



- **IP-Adresse:**

Entry of a fixed IP address as specified by IT

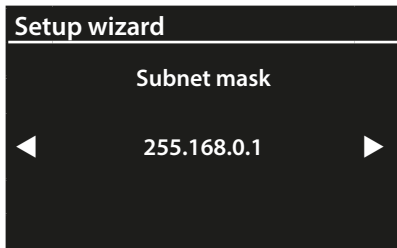



- **Subnet mask:**

Entering the subnet mask

- **Gateway:**

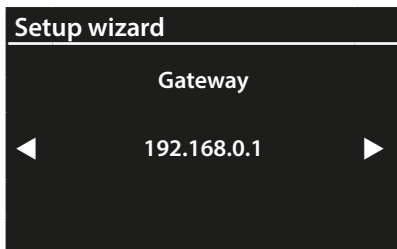
Entering a gateway



	<p>In the factory setting, the multimess F144-PQ is factory pre-set with the IP address 192.168.56.95 and the subnet mask 255.255.0.0.</p>
---	--

4.3.11 Wizard setting Security Mode



● Security Mode:

Active: high security mode

The device is set up in security mode.

Communication is encrypted and device access is protected. The completion of the commissioning in security mode requires the setup of the necessary user accounts and must be completed with the software WinPQ or WinPQ lite with version 5.0 or higher. All details on encryption technology etc. are described in the security documentation.

Inactive compatible mode

The installation of devices in compatibility mode results in a non IT-secure operation of the measuring device, if no other measures for the encryption of the connection are available in the used network (e.g. VPN solutions with encryption / disconnected network or similar), because neither the communication between WinPQ software and the PQ device is encrypted nor the device access is protected. This mode is intended for compatibility with WinPQ systems smaller than version 5 and systems with WinPQ versions 5 or higher should be operated in high security mode..



In any case, make a note of the serial number of your measuring instrument!



When the SD card is inserted, an identification file with the required certificates for the recognition of the device is stored in the root directory of the SD card when the device is restarted.

	<p>The separate security documentation for administrators describes all security-relevant system settings for setting up and operating the device and the entire PQ system (requirement of the BDEW Whitepaper).</p>
---	--

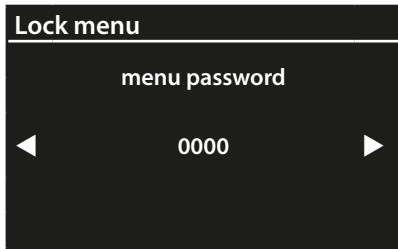

In the active security mode it is recommended to password the display in addition to the encryption.

4.3.13 Wizard End of commissioning



● **Accept settings:**

At this point all settings for the device can be accepted or the setup wizard can be cancelled.

If the wizard is aborted, the wizard will appear again and again each time the device is restarted because the necessary basic settings have not been made.

With the confirmation „Yes“

- restarts the device,
- the device accepts all changes,
- the device deletes all old measurement data in the device memory,
- many parameters are reset to factory settings.

The measurement campaign is started after the restart, all recorders are active.

5. Technical Data

5.1 Dimensions / Weight

Dimensions / Weight: (L x B x H)	144 x 144 x 90 mm without terminals 144 x 150 x 110 mm with terminals
Outbreak size::	138 x 138 mm (+0,8 mm)
Weight:	1220 g

5.2 Electrical safety – environmental parameter

Environmental parameters	Storage and transport	Operation
Ambient temperature : Limit range of operation	IEC 60721-3-1 / 1K5 -40 ... +70 °C IEC 60721-3-2 / 2K4 -40 ... +70 °C	IEC 61010 H1: -25 ... +45°C H2/H3: -25 ... +50°C
Ambient temperature : Rated range of operation	—	IEC DIN EN 61010 US8: -25... +45 °C US9: -25... +50 °C
Relative humidity: 24h average No condensation or ice	5...95 %	5...95 %
Solar radiations	—	700 W/m ²
Vibration, earth tremors	IEC 60721-3-1 / 1M1 IEC 60721-3-2 / 2M1	IEC 60721-3-3 / 3M1

5.3 Power supply

Merkmal	US8	US9
AC Nominal range	100 – 240 V	
AC Operating range	90 – 264 V	
DC Nominal range	120 – 320 V	24 – 60 V
DC Operating range	108 – 350 V	18 – 75 V
Power consumption	≤ 10 W < 20 VA	≤ 10 W
Frequency Nominal	50 – 60 Hz	DC
Frequency Operating	40 – 70 Hz	DC
External fuse characteristics	6A B	6A B
Energy storage	2 Sek.	2 Sek.
Electrical safety IEC 61010-1:2010 + Cor.: 2011, DIN EN 61010-1: 2011	CAT II	CAT II

5.4 Voltage Inputs

Voltage inputs	
Channels	U1, U2, U3, U _{N/E/4}
Electrical safety DIN EN 61010	300V CAT IV 600V CAT III
Input reference level	PE
Impedance -> PE	10 MΩ 25pF
Nominal input voltage U _N	230 V _{AC}
Full scale range (FSR)	0 – 480 V _{AC} L-E
Waveform	Jede AC / DC
Maximum crest factor @ U _N	3
Bandwidth	DC – 20 kHz
Nominal power frequency f _N	50 Hz / 60 Hz
Frequency range of the fundamental	f _N ± 15 % 42,5..50..57,5 Hz 51,0..60..69,0 Hz

5.5 Current Inputs

Current Inputs	
Channels	I1, I2, I3, IN/4
Electrical safety	300 V CAT III
Input type	Differential, isolated
Impedance	$\leq 4 \text{ m}\Omega$
Nominal input current I_N	5 A _{AC}
Full scale range (FSR)	10 A _{AC}
Overload capacity permanent	20 A
$\leq 10\text{s}$	100 A
$\leq 1\text{s}$	500 A
Waveform	AC, any
Maximaler Crest-Faktor @ I_N	4
Bandwith	25 Hz...20 kHz

Residual current monitor (RCM) – from firmware version 2.2	
Nominal current I_N	30 mA
Impedance	4 Ω
Overload capacity	5 A (1 seconds)
Resolution	24 Bit-ADC

5.6 Binary inputs

Binary inputs (BI)	
8 binary inputs Range	0 V..250 V _{AC} / V _{DC}
H – Level	> 35 V
L – Level	< 20 V
Signal frequency	DC ... 70 Hz
Input resistance	> 100 k Ω
Electrical isolation	Optocoupler, electrically isolated
Electrical safety DIN EN 61010	300 V

5.7 Binary outputs

Binary outputs (BO)	
4 binary outputs	3 x closer 1 x changeover
Contact specification (EN60947-4-1, -5-1)	
Configuration	3 x SPST (Single Pole Single Throw) 1 x SPDT (Single Pole Double Throw)
Nominal voltage	250 VAC
Nominal current	6 A
Nominal load AC1	1500 VA
Nominal load AC15, 230 VAC	300 VA
Interrupting power DC1, 30/110/220 V	6/0,2/0,12 A
Number of switching operations AC1	$\geq 60 \cdot 10^3$ electrical
Electrical Isolation	Isolated from all internal potentials
Input resistance	> 100 k Ω
Electrical safety IEC61010	300 V CAT II

5.8 Temperature Input

Temperature input PT100 / PT1000 / KTY – (from firmware version 2.2)	
Contacting measurement sensor (software setting)	2 wire
	3 wire
	4 wire
Update rate	1 Second / 1 Hz
Resolution	15 Bit
Burden	1,9 k Ω
Accuracy	0.05% FSR

5.9 Electrical safety

Electrical safety	
– IEC 61010-1 – IEC 61010-2-030	
Protection class	1
Pollution degree	2
Overvoltage category mains supply option: US8 US9	300 V / CAT II 150 V / CAT II
Measurement category	300 V / CAT IV 600 V / CAT III
Altitude	≤ 2000 m
IP protection class in installed condition	IP20

Electromagnetic Compatibility	
Immunity	IEC 61000-6-5, Environment H
Emissions	CISPR22 (EN 55022) , Class A

5.10 Connection / terminals

Please observe the safety guidelines in chapter 3 Commissioning!

Terminal strip no.	Designation	Function	Terminal no.	cross section [mm ²]	Stripping length [mm]	Torque [Nm]
X1	Auxiliary voltage	L (+)	11	0,2 – 2,5	6	0,5 – 0,6
		N (-)	12	0,2 – 2,5	6	0,5 – 0,6
	Ground	PE	13	ring terminals M4	8	0,5 – 0,6
X2	BICOM	–	21	solid: 0,2 – 1,5 flexible: 0,2 – 2,5	10	0,5 – 0,6
	BI1	+	22		10	0,5 – 0,6
	BI2	+	23		10	0,5 – 0,6
	BI3	+	24		10	0,5 – 0,6
	BI4	+	25		10	0,5 – 0,6
	BI5	+	26		10	0,5 – 0,6
	BI6	+	27		10	0,5 – 0,6
	BI7	+	28		10	0,5 – 0,6
X3	U ₁	L1	31	0,2 – 2,5	10	0,5 – 0,6
	U ₂	L2	32		10	0,5 – 0,6
	U ₃	L3	33		10	0,5 – 0,6
	U ₄	N/E	34		10	0,5 – 0,6
X4	T1	RTDOUT+	41	0,14 – 0,5	10	0,5 – 0,6
		RTDIN+	42		10	0,5 – 0,6
		RTDIN–	43		10	0,5 – 0,6
		RTDOUT–	44		10	0,5 – 0,6
X5	R1	NO	51	solid: 0,2 – 1,5 flexible: 0,2 – 2,5	10	0,5 – 0,6
		NC	52		10	0,5 – 0,6
		COM	53		10	0,5 – 0,6
	R2	NO (+)	54		10	0,5 – 0,6
		Pol (–)	55		10	0,5 – 0,6
	R3	NO (+)	56		10	0,5 – 0,6
		Pol (–)	57		10	0,5 – 0,6
	R4	NO (+)	58		10	0,5 – 0,6
Pol (–)		59	10	0,5 – 0,6		

Continued on next page

Continued: Table 5.10 Connection / terminal

Terminal strip no.	Designation	Function	Terminal no.	cross section [mm ²]	Stripping length [mm]	Torque [Nm]
X2	I1	S1 (K)	61	ring terminals 1,5 – 4 mm ²		0,5 – 0,8
		S2 (L)	62			
	I2	S1 (K)	63			0,5 – 0,8
		S2 (L)	64			
	I3	S1 (K)	65			0,5 – 0,8
		S2 (L)	66			
	I4	S1 (K)	67			0,5 – 0,8
		S2 (L)	68			
X3	I5	+	91	solid: 0,2 – 1,5	10	0,5 – 0,6
		-	92	flexible: 0,2 – 2,5	10	0,5 – 0,6



Connection cables to be used

- Provide safety devices (fuse) for CAT II.
- Do not mix touchable and dangerous active circuits.
- Connection cables must be designed for a temperature of at least 62°C.

KBR GmbH

Am Kieferschlag 7
D-91126 Schwabach

T +49 (0) 9122 6373 -0
F +49 (0) 9122 6373 -83
E info@kbr.de

www.kbr.de